

**SECTION 2 - CONTRACTOR'S PROPOSAL**

CONTRACTOR'S NAME: ISSA ELECTRIC, INC.

THE HONORABLE MAYOR AND CITY COUNCIL  
 CITY OF GARDEN GROVE  
 11222 ACACIA PARKWAY  
 GARDEN GROVE, CALIFORNIA 92840

SUBJECT PROJECT: **GARDEN GROVE PARK IMPROVEMENTS-PHASE 2**  
**CITY PROJECT NO. 2163101280-2**

**Potential Bidders:**

The undersigned, having carefully examined the Plans and Specifications for the above subject project and having personally visited the site of the work and been made familiar with the conditions, HEREBY PROPOSE to furnish all labor, materials, equipment and transportation, and do all the work required to complete the said work in accordance with the said Plans and Specifications for the unit prices named in the following bid proposal:

**BID PROPOSAL**

ITEM NO.	APPROX. QUANTITY	ITEM WITH UNIT WRITTEN IN WORDS	UNIT PRICE	ITEM TOTAL
1	300-1.4	1 LS Mobilization (maximum 6%) <u>Five thousand dollars with zero cents.</u>	<u>\$ 5,000.<sup>00</sup></u>	<u>\$ 5,000.<sup>00</sup></u>
			Per Lump Sum	
2	300-1.4	1 LS Demolition / Clearing & Grubbing <u>Twenty seven thousand two hundred twenty three dollars with twenty cents.</u>	<u>\$ 27,223.<sup>20</sup></u>	<u>\$ 27,223.<sup>20</sup></u>
			Per Lump Sum	
3	300-2.9	1 LS Grading <u>Eighteen thousand nine hundred twelve dollars with zero cents.</u>	<u>\$ 18,912.<sup>00</sup></u>	<u>\$ 18,912.<sup>00</sup></u>
			Per Lump Sum	
4	303-5.9	720 SF Concrete Paving <u>Thirty seven thousand six hundred thirty eight dollars with six cents.</u>	<u>\$ 37,638.<sup>06</sup></u>	<u>\$ 37,638.<sup>06</sup></u>
			Per Square Foot	
5	303-5.9	436 LF Play Area Curb <u>Twenty five thousand six hundred fifty dollars with ninety six cents.</u>	<u>\$ 25,650.<sup>96</sup></u>	<u>\$ 25,650.<sup>96</sup></u>
			Per Linear	
6	313-1.1	1 LS Storing & Installing Play Equipment <u>Twenty three thousand one hundred twelve dollars with zero cents.</u>	<u>\$ 23,112.<sup>00</sup></u>	<u>\$ 23,112.<sup>00</sup></u>

**SECTION 2 – CONTRACTOR’S PROPOSAL ... (continued)**

ITEM NO.	APPROX. QUANTITY	ITEM WITH UNIT WRITTEN IN WORDS	UNIT PRICE	ITEM TOTAL
Per Lump Sum				
7	315-1.8	5060 SF Resilient Play Surfacing & Slurry Base <i>One hundred Sixty Eight thousand with zero cents.</i>	<i>\$ 1128,000</i>	<i>\$ 1128,000.<sup>00</sup></i>
Per Square Foot				
8	313-1.1	1 Storing & Installing 2-5 Play Area Shade Canopy <i>Twenty thousand One hundred twelve dollars with zero cents</i>	<i>\$ 20,112.<sup>00</sup></i>	<i>\$ 20,112.<sup>00</sup></i>
Per Each				
9	313-1	4 LS Installing Benches <i>Three thousand One hundred fifty two dollars with zero cents.</i>	<i>3,152.<sup>00</sup></i>	<i>3,152.<sup>00</sup></i>
10	316-3	1 LS Electrical Improvements <i>Thirty Six thousand dollars with zero cents.</i>	<i>\$ 36,000.<sup>00</sup></i>	<i>\$ 36,000.<sup>00</sup></i>
Per Lump Sum				
11	801-8	4,000 Soil Preparation / Fine Grading <i>Six thousand dollars with zero cents.</i>	<i>\$ 6,000.<sup>00</sup></i>	<i>\$ 6,000.<sup>00</sup></i>
Per Square Foot				

**Total Written in Words:**

**Total in Figures**

*Three hundred Seventy thousand  
Eight hundred dollars with twenty  
Two cents.* **\$ 370,800.<sup>22</sup>**

1. The quantities listed for each item in the Proposal Bid Sheets are supplied to give an indication of the general scope of work, but the accuracy of these figures is not guaranteed and the BIDDER shall make his own estimates from the Plans & Specifications. In case of a variation between the Unit Price and the corresponding item Total shown by the BIDDER, the Unit Price shall be considered to be the Bid. The Bidder will be paid for each item by the actual quantity required and installed on the project. The City of Garden Grove reserves the right to increase or decrease the amount of any class or portion of the work as may be deemed necessary or expedient by the Project Manager.

2. The City of Garden Grove desires to construct all improvements within these Plans & Specifications. However, the CITY reserves the right to reject portions or all of the above bid items if sufficient funds are not available, or the CITY determines it is not in the CITY's best interest to award the Contract.

**NOTES:**

1. In case of discrepancy between the words and figures, the words shall prevail.
2. The aforementioned quantities are approximate only, being given as a basis for the comparison of bids, and the City of Garden Grove does not expressly or by implication, agree that the actual amount of work will correspond therewith, but reserves the right to increase or decrease the amount of any class or portion of work as may be deemed necessary or expedient by the Project Manager.

It is understood and agreed that:

(a) Pursuant to Section 1773.2 of the Labor Code, general prevailing wage rates established by the Director of the Department of Industrial Relations shall be posted by the Contractor at a prominent place at the site of the work.

The Federal Davis-Bacon Act prevailing wages apply to the work. If there is a difference in the minimum wage rate predetermined by the Secretary of Labor and the prevailing wage rates determined by the Director of Industrial Relations, for similar classifications of labor, the Contractor and its subcontractors shall pay not less than the highest wage rate.

(b) No verbal agreement or conversation with any officer, agent or employee of CITY, either before or after the execution of the Agreement shall affect or modify any of the terms or obligations of this Proposal.

(c) CITY will not be responsible for any errors or omissions on the part of the undersigned in making up their bid, nor will bidders be released because of errors.

(d) The undersigned is licensed in accordance with the laws of the State of California.

(e) The undersigned hereby certifies that this Proposal is genuine and is not sham or collusive, or made in the interest or on behalf of any person not herein named, and that the undersigned has not directly or indirectly induced or solicited any other bidder to put in a sham bid; or any other person, firm or corporation to refrain from bidding, that the undersigned has not in any manner sought, by collusion, to secure for itself an advantage over any other bidder and that the unit prices proposed herein shall remain fully in effect for 180 calendar days from bid opening.

I declare under penalty of perjury that all statements or representations made herein are true and correct.

ISSA ELECTRIC, INC.

\_\_\_\_\_  
BIDDER'S NAME

  
\_\_\_\_\_  
AUTHORIZED SIGNATURE

Corporation

\_\_\_\_\_  
TYPE OF ORGANIZATION: INDIVIDUAL,  
PARTNERSHIP OR CORPORATION

3994 Mennes Avenue, Riverside, CA 92509

\_\_\_\_\_  
ADDRESS

(909)772-0216

(951)374-0043

\_\_\_\_\_  
TELEPHONE

\_\_\_\_\_  
FAX

06/30/2022

1028054

\_\_\_\_\_  
EXPIRATION DATE

\_\_\_\_\_  
STATE OF CALIFORNIA LICENSE NUMBER

**SECTION 3 - DESIGNATION OF SUBCONTRACTORS/REFERENCES**

1. The undersigned certifies that the sub-bids of the following listed subcontractors have been used in making up this bid, and that the subcontractors listed will be used for the work for which they bid, subject to the approval of the Community Services Manager, and in accordance with the applicable provisions of the Specifications.

Bidder's Full and Legal Name Issa Electric, Inc.

**PART I**

The bidder shall list all subcontractors (both DBE and non-DBE) in pursuant to Public Contract Code Sections §4104 of California Public Contract Code. This listing is required in addition to listing DBE Subcontractors elsewhere in the proposal. Photocopy this form for additional firms.

Firm Name/LICENSE NUMBER Address/ City, State, ZIP	Phone/ Fax	Annual Gross Receipts	Description of items of Work to be Performed	Local Agency Use Only (Certified DBE?)
Name SPECTRATURF	Phone 951-736-3579	<input type="checkbox"/> < \$1 million <input type="checkbox"/> < \$5 million <input type="checkbox"/> < \$10 million <input checked="" type="checkbox"/> < \$15 million <input type="checkbox"/> > \$15 million	PROVIDE & INSTALL PLAYGROUND SAFETY SURFACING	<input type="checkbox"/> YES <input type="checkbox"/> NO If YES list DBE #
Address 555 S. PROMENADE AVE. #103	Fax 951-734-3630			Age of Firm (Yrs.)
City State ZIP CORONA, CA 92879				
Name	Phone	<input type="checkbox"/> < \$1 million <input type="checkbox"/> < \$5 million <input type="checkbox"/> < \$10 million <input type="checkbox"/> < \$15 million <input type="checkbox"/> > \$15 million		<input type="checkbox"/> YES <input type="checkbox"/> NO If YES list DBE #
Address	Fax			Age of Firm (Yrs.)
City State ZIP				
Name	Phone	<input type="checkbox"/> < \$1 million <input type="checkbox"/> < \$5 million <input type="checkbox"/> < \$10 million <input type="checkbox"/> < \$15 million <input type="checkbox"/> > \$15 million		<input type="checkbox"/> YES <input type="checkbox"/> NO If YES list DBE #
Address	Fax			Age of Firm (Yrs.)
City State ZIP				
Name	Phone	<input type="checkbox"/> < \$1 million <input type="checkbox"/> < \$5 million <input type="checkbox"/> < \$10 million <input type="checkbox"/> < \$15 million <input type="checkbox"/> > \$15 million		<input type="checkbox"/> YES <input type="checkbox"/> NO If YES list DBE #
Address	Fax			Age of Firm (Yrs.)
City State ZIP				

**SECTION 4 – AFFIDAVIT TO ACCOMPANY PROPOSAL**

**USE THIS FORM WHEN BIDDER IS AN INDIVIDUAL**

State of California )  
County of Orange ) ss.

(Name) \_\_\_\_\_, Affiant,  
being first duly sworn, deposes and says:

That it is the bidder who makes the accompanying proposal; that such proposal is genuine, and not sham or collusive, nor made in the interest or on behalf of any person not herein named, and that the bidder has not directly or indirectly induced or solicited any other bidder to put in a sham bid, or any other person, firm or corporation to refrain from bidding, and that the bidder has not in any manner sought by collusion to secure for itself an advantage over any other bidder.

Subscribed and sworn to before me \_\_\_\_\_

This \_\_\_\_\_ day of \_\_\_\_\_, 20\_\_\_\_.

Signature: \_\_\_\_\_

Notary Public in and for the County of \_\_\_\_\_, State of \_\_\_\_\_

**USE THIS FORM WHEN BIDDER IS A CORPORATION**

State of California )  
County of Orange ) ss.

Juan Manuel Sanchez affiant, the Manager  
Pres., Sec., or Mgr. Ofcr  
of ISSG Electric Inc  
Name of Corporation

The corporation who makes the accompanying proposal, having first been duly sworn, deposes and says: That such proposal is genuine and not sham or collusive, nor made in the interest or on behalf of any person not herein named, and that the bidder has not directly or indirectly induced or solicited any other bidder to put in a sham bid, or any other person, firm or corporation to refrain from bidding, and that the bidder has not in any manner sought by collusion to secure for itself an advantage over any other bidder.

\_\_\_\_\_  
Signature  
President, Secretary or Managing Officer

Subscribed and sworn to before me

This 11 day of April, 2022.

Notary Public in and for the County of Orange, State of California

Signature: Parker Alchanati

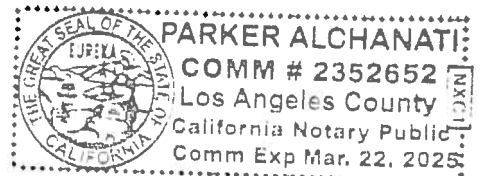

**SECTION 4 – AFFIDAVIT TO ACCOMPANY PROPOSAL (Continued)**

**USE THIS FORM WHEN BIDDER IS A CO-PARTNERSHIP**

State of California    )  
County of Orange    ) ss.

\_\_\_\_\_, Affiant(s),  
Being first duly sworn, each for itself deposes and says:

That \_\_\_\_\_  
(Names of all Partners)

are partners, doing business under the firm name and style of

\_\_\_\_\_ and that said co-partnership  
(Name of Firm)

makes the accompanying proposal; that such proposal is genuine, and not sham or collusive, nor made in the interest or on behalf of any person not herein named, and that the bidder has not directly or indirectly induced or solicited any other bidder to put in a sham bid, or any other person, firm or corporation to refrain from bidding, and that the bidder has not in any manner sought by collusion to secure for itself an advantage over any other bidder.

Subscribed and sworn to before me \_\_\_\_\_

This \_\_\_\_\_ day of \_\_\_\_\_, 20\_\_\_\_.

Notary Public in and for the County of

\_\_\_\_\_, State of \_\_\_\_\_

Signature: \_\_\_\_\_



(THE BIDDER'S EXECUTION ON THE SIGNATURE PORTION OF THIS PROPOSAL SHALL ALSO CONSTITUTE AN ENDORSEMENT AND EXECUTION OF THOSE CERTIFICATIONS WHICH ARE A PART OF THIS PROPOSAL)

**EQUAL EMPLOYMENT OPPORTUNITY CERTIFICATION**

The bidder ISSA ELECTRIC, INC.

[proposed subcontractor,] \_\_\_\_\_ hereby certifies that he/she/it has, has not, participated in a previous contract or subcontract subject to the Equal Opportunity clauses, as required by Executive Orders 10925, 11114, or 11246, and that, where required, he/she/it has filed with the Joint

Reporting Committee, the Director of the Office of Federal Contract Compliance, a Federal Government contracting or administering agency, or the former President's Committee on Equal Employment Opportunity, all reports due under the applicable filing requirements.

Note: The above certification is required by the Equal Employment Opportunity Regulations of the Secretary of Labor (41 CFR 60-1.7(b) (1)), and must be submitted by bidders and proposed subcontractors only in connection with contracts and subcontracts which are subject to the equal opportunity clause. Contracts and subcontracts which are exempt from the equal opportunity clause are set forth in 41 CFR 60-1.5. (Generally only contracts or subcontracts of \$ 10,000 or under are exempt.)

Currently, Standard Form 100 (EEO-I) is the only report required by the Executive Orders or their implementing regulations. ([eeoc.gov/employers/eeol\\_survey/index.cfm](http://eeoc.gov/employers/eeol_survey/index.cfm))

Proposed prime contractors and subcontractors who have participated in a previous contract or subcontract subject to the Executive Orders and have not filed the required reports should note that 41 CFR 60-1.7(b) (1) prevents the award of contracts and subcontracts unless such contractor submits a report covering the delinquent period or such other period specified by the Federal Highway Administration or by the Director, Office of Federal Contract Compliance, U.S. Department of Labor.

Signature:  Date: 4-11-2022

Print Name: Juan Sanchez

Title: Project Manager



### **Equal Employment Opportunity Clause**

During the performance of this contract, the Contractor agrees as follows:

- (a) The Contractor shall not discriminate against any employee or applicant for employment because of race, color, religion, sex, national origin, or handicap.
- (b) The Contractor shall take affirmative action to ensure that applicants are employed, and that employees are treated during employment without regard to their race, color, religion, sex, national origin, or handicap. Such action shall include, but not be limited to, (1) employment, (2) upgrading, (3) demotion, (4) transfer, (5) recruitment or recruitment advertising, (6) layoff or termination, (7) rates of pay or other forms of compensation, and (8) selection for training, including apprenticeship.
- (c) The Contractor shall post in conspicuous places available to employees and applicants for employment the notices to be provided by the Contracting Officer that explain this clause.
- (d) The Contractor shall, in all solicitations or advertisements for employees placed by or on behalf of the Contractor, state that all qualified applicants will receive consideration for employment without regard to race, color, religion, sex, national origin, or handicap.
- (e) The Contractor shall send, to each labor union or representative of workers with which it has a collective bargaining agreement or other contract or understanding, the notice to be provided by the Contracting Officer advising the labor union or workers' representative of the Contractor's commitments under this clause, and post copies of the notice in conspicuous places available to employees and applicants for employment.
- (f) The Contractor shall comply with Executive Order 11246, as amended, and the rules, regulations, and orders of the Secretary of Labor.
- (g) The Contractor shall furnish all information and reports required by Executive Order 11246, as amended, Section 503 of the Rehabilitation Act of 1973, as amended, and by rules, regulations, and orders of the Secretary of Labor, or pursuant thereto. The Contractor shall permit access to its books, records, and accounts by the Secretary of Labor for purposes of investigation to ascertain compliance with such rules, regulations, and orders.
- (h) In the event of a determination that the Contractor is not in compliance with this clause or any rule, regulation, or order of the Secretary of Labor, this contract may be canceled, terminated, or suspended in whole or in part, and the Contractor may be declared ineligible for further Government contracts, or Federally assisted construction contracts under the procedures authorized in Executive Order 11246, as amended. In addition, sanctions may be imposed and remedies invoked against the Contractor as provided in Executive Order 11246, as amended, the rules, regulations, and orders of the Secretary of Labor, or as otherwise provided by law.
- (i) The Contractor shall include the terms and conditions of this clause in every subcontract or purchase order unless exempted by the rules, regulations, or orders of the Secretary of Labor issued under Executive Order 11246, as amended, so that these terms and conditions will be binding upon each subcontractor or vendor. The Contractor shall take such action with respect to any subcontract or purchase order as the Secretary of Housing and Urban Development or the Secretary of Labor may direct as a means of enforcing such provisions, including sanctions for noncompliance; provided that if the Contractor becomes involved in, or is threatened with, litigation with a subcontractor or vendor as a result of such direction, the Contractor may request the United States to enter into the litigation to protect the interests of the United States.
- (j) Compliance with the requirements of this clause shall be to the maximum extent consistent with, but not in derogation of, compliance with section 7(b) of the Indian Self-Determination and Education Assistance Act and the Indian Preference clause of this contract.

## **PUBLIC CONTRACT CODE**

### **Public Contract Code Section 10285.1 Statement**

In conformance with Public Contract Code Section 10285.1 (Chapter 376, Stats. 1985), the bidder hereby declares

Under penalty of perjury under the laws of the State of California that the bidder has , has not  been convicted within the preceding three years of any offenses referred to in that section, including any charge of fraud, bribery, collusion, conspiracy, or any other act in violation of any state or Federal antitrust law in connection with the bidding upon, award of, or performance of, any community services contract, as defined in Public Contract Code Section 1101, with any public entity, as defined in Public Contract Code Section 1100, including the Regents of the University of California or the Trustees of the California State University. The term "bidder" is understood to include any partner, member, officer, director, responsible managing officer, or responsible managing employee thereof, as referred to in Section 10285.1.

**Note:** The bidder must place a checkmark after "has" or "has not" in one of the blank spaces provided. The above Statement is part of the Proposal. Signing this Proposal on the signature portion thereof shall also constitute signature of this Statement. Bidders are cautioned that making a false certification may subject the certifier to criminal prosecution.

---

### **Public Contract Code Section 10162 Questionnaire**

In conformance with Public Contract Code Section 10162, the Bidder shall complete, under penalty of perjury, the following questionnaire:

Has the bidder, any officer of the bidder, or any employee of the bidder who has a proprietary interest in the bidder, ever been disqualified, removed, or otherwise prevented from bidding on, or completing a federal, state, or local government project because of a violation of law or a safety regulation?

Yes  No

If the answer is yes, explain the circumstances in the following space.

### **Public Contract Code 10232 Statement**

In conformance with Public Contract Code Section 10232, the Contractor, hereby states under penalty of perjury, that no more than one final unappealable finding of contempt of court by a federal court has been issued against the Contractor within the immediately preceding two-year period because of the Contractor's failure to comply with an order of a federal court which orders the Contractor to comply with an order of the National Labor Relations Board.

**Note:** The above Statement and Questionnaire are part of the Proposal. Signing this Proposal on the signature portion thereof shall also constitute signature of this Statement and Questionnaire.

Bidders are cautioned that making a false certification may subject the certifier to criminal prosecution.

---

**Noncollusion Affidavit**  
(Title 23 United States Code Section 112 and  
Public Contract Code Section 7106)

[NAME OF CONTRACT] ISSA ELECTRIC, INC.

To the City of Garden Grove  
*DEPARTMENT OF COMMUNITY SERVICES.*

In conformance with Title 23 United States Code Section 112 and California Public Contract Code 7106 the bidder declares that the bid is not made in the interest of, or on behalf of, any undisclosed person, partnership, company, association, organization, or corporation; that the bid is genuine and not collusive or sham; that the bidder has not directly or indirectly induced or solicited any other bidder to put in a false or sham bid, and has not directly or indirectly colluded, conspired, connived, or agreed with any bidder or anyone else to put in a sham bid, or that anyone shall refrain from bidding; that the bidder has not in any manner, directly or indirectly, sought by agreement, communication, or conference with anyone to fix the bid price of the bidder or any other bidder, or to fix any overhead, profit, or cost element of the bid price, or of that of any other bidder, or to secure any advantage against the public body awarding the contract of anyone interested in the proposed contract; that all statements contained in the bid are true; and, further, that the bidder has not, directly or indirectly, submitted his or her bid price or any breakdown thereof, or the contents thereof, or divulged information or data relative thereto, or paid, and will not pay, any fee to any corporation, partnership, company association, organization, bid depository, or to any member or agent thereof to effectuate a collusive or sham bid.

Note: The above Noncollusion Affidavit is part of the Bidder's Proposal. By signing the Proposal, the Bidder has also signed this Noncollusion Affidavit.

Bidders are cautioned that making a false Certification may subject the Bidder to criminal prosecution.

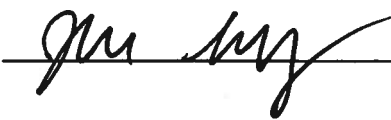
Signature:  Date: 4-11-2022

Print Name: Juan Sanchez

Title: Project Manager

A notary public or other officer completing this certificate verifies only the identity of the individual who signed the document to which this certificate is attached, and not the truthfulness, accuracy, or validity of that document.

State of California  
County of Orange

Subscribed and sworn to (or affirmed) before me on this 11  
day of April, 2022, by Juan Sanchez

proved to me on the basis of satisfactory evidence to be the person(s) who appeared before me.

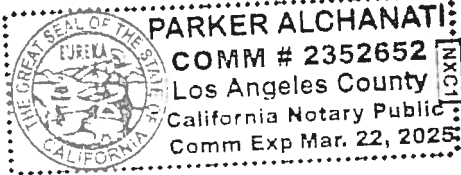

(Seal)

Signature Parker Alchanati

**SECTION 4 B - QUESTIONNAIRE TO GENERAL CONTRACTORS**

1. Has any person or group threatened you with subcontractor boycotts, union boycotts, or other sanctions to attempt to convince you to use the services or abide by the rules of one or more bid depositories?  
Yes ( )                      No (x)

2. If the answer to No. 1 is "yes," please explain the following details:

(a) Date(s):

(b) Name of person or group:

(c) Job involved (if applicable):

(d) Nature of threats:

(e) Additional comments:  
(Use additional paper if necessary)

We declare under penalty of perjury that the foregoing is true and correct.

Dated this 11 day of April, 2022.

ISSA ELECTRIC, INC.

**Name of Company**

By Juan Sanchez

Project Manager

**Title**

ADDENDUM No. 1

Covering

CHANGE IN SPECIFICATIONS AND/OR PLANS

Date Issued: March 21, 2022

Date Effective: March 21, 2022

IFB No. City Project 2163101280-2 Garden Grove Park Improvements-Phase Two Project

INTENT

1. This addendum is issued prior to receipt of bids to provide for modifications in plans and/or specifications. Acknowledgment of this addendum shall be made and cost for work included in proposer's submittal.
2. The following questions were asked regarding the project named above. The City's responses can be found in the bold and italicized font.
  1. Is there an Engineer's Estimated Value for the project? ***An Engineer's Estimated Value cost for this project is not available.***
  2. Is the project subject to a PLA (Project Labor Agreement), a PSA (Project Stabilization Agreement), a CBA (Collective Bargaining Agreement), a CWA (Community Workforce Agreement), or anything of that nature? ***This project is not subject to these type of agreements.***
  3. What is the process for submitting "alternatives" or "proposed equals" for the City's review? ***The Bidder shall note in his submittal any and all "alternatives" or "proposed equals" that it proposes to use in lieu of any named or designated material, product or thing that is named in the specifications and followed by the words "or equal." In the event there are "alternatives" or "proposed equals", the bidder shall specifically itemize them in his bid under a heading entitled "Proposed Equals". Failure to do so shall render the bidder's bid non-responsive. In addition, if any "alternatives" or "proposed equals" are proposed by the bidder, the bidder must submit a request for substitution of proposed equal to the City within ten (10) working days of the bid closing date. This request shall include any and all appropriate data substantiating that the proposed item is "equal" to the item listed in the specifications. Failure to submit said request within the required timeframe shall be cause for its immediate rejection by the City. The City shall review the bidder's submission and shall render a decision no later than five (5) business days before the bid closing date. The bidder shall be notified in writing of the City's decision. The City reserves***

***the right to reject any and all bids that do not meet the bid requirements and/or those bids submitted with "alternatives" or "proposed equals" that have not been previously approved by the City. The final decision as to whether or not any "alternatives" or "proposed equals" will be accepted shall be at the the City's sole discretion. All requests for substitution or proposed equals shall be submitted via email to janetp@ggcity.org.***

The contractor is hereby notified that Addendum 1 must be acknowledged and submitted as part of the bid. Failure to do so, could result in the City designating said bid as "Non Responsive". All other terms and conditions of the BID shall remain the same.

Issued by: Sandra Segawa  
Sandra Segawa, C.P.M., CPPB  
Purchasing Division Manager  
City of Garden Grove



ADDENDUM No. 2

Covering

CHANGE IN SPECIFICATIONS AND/OR PLANS

Date Issued: March 24, 2022

Date Effective: March 24, 2022

IFB No. City Project 2163101280-2 Garden Grove Park Improvements-Phase Two Project

INTENT

1. This addendum is issued prior to receipt of bids to provide for modifications in plans and/or specifications. Acknowledgment of this addendum shall be made and cost for work included in proposer's submittal.
2. The following questions were asked regarding the project named above.

Q: How many light poles and benches are part of the project?

A: 4 benches and 4 light pole fixtures

Q: Do you have the engineer estimated cost?

A: The City does not have an estimated cost. This question was already answered in Addendum No. 1. All bidders are responsible for checking the City's Planet Bids portal for addenda that are posted.

Q: What is the anticipated award and start date?

A: Bids will be opened on April 11, 2022 and will go through the lowest/responsible bidder process. It is anticipated that the City will award the contract and have the contractor on board by early May, 2022. The City is expecting to receive playground equipment in May, 2022.

Q: Where are the bids to be submitted?

A: This information is in the bid package, bidders can either mail or drop off in person at the Annex Building adjacent to City Hall. If bids are hand deliver, a confirmation receipt can be issued.

Q Is Planet Bids also an option for submitting bids?

A: No. Registration would need to go through Planet Bids but the bid package itself must be mailed or dropped off in person to the address noted in the bid document.

Q: If already registered on Planet Bids as a plan holder, does one get automatic notifications for things such as addendums?

A: All bidders who are registered on the City's PlanetBids portal will receive emails when an addendum has been posted. Please make sure that these emails are not going to a spam file. The City is not responsible for emails that go to spam files. Once registered on the City's Planet Bids portal, bidders

must log into the bid and open the bid document to be moved into "Prospective Bidder" status. If these steps are not followed, information will be not be emailed. Please keep in mind that it is the responsibility of all bidders to check the City's PlanetBids portal for addenda and all updates.

Q: I have not seen any addendums.

A: Please see the response to the previous question.

Q: Is shade canopy part of the project?

A: Yes, it is part of the playground equipment.

Q: What was on the addendum?

A: A couple of items were answered: 1) Engineer's estimated cost; 2) Identified process if company wants to be considered an equal for playground surface; and 3) If there were other type of agreements that are part of this project. Please email any additional questions to [janetp@ggcity.org](mailto:janetp@ggcity.org) by the specified deadline.

Q: Can you provide a list of contractors that attended this mandatory job walk?

A: The mandatory sign in sheet has been posted on the City's PlanetBids portal for this bid. The document can be found under the "Documents" tab.

3. The following items apply to the Scope of Work and must be taken into consideration by all bidders:

Project Manager informed proposed bidders that the selected contractor will be working with the playground company for any specific questions regarding installation of the units. Irrigation work will be handled in-house by City staff. The old playground equipment will be removed by City staff.

Proposed bidders should include cost for the storage of the playground equipment, under line item Storing & Installing Playground. Additionally, the selected Contractor will be responsible to receive, verify and store the playground equipment prior to installation. The storage can be done at the project site in an approved location by the City, but any container units used will be an expense covered by the Contractor. Contractor will be responsible to secure all equipment and work completed at job site, especially when the playground surface is poured.

The contractor is hereby notified that Addenda 1 and 2 must be acknowledged and submitted as part of the bid. Failure to do so, could result in the City designating said bid as "Non Responsive". All other terms and conditions of the BID shall remain the same.

Issued by: *Sandra Segawa*  
Sandra Segawa, C.P.M., CPPB  
Purchasing Division Manager  
City of Garden Grove

## ADDENDUM No. 3

### Covering

#### CHANGE IN SPECIFICATIONS AND/OR PLANS

Date Issued: March 31, 2022

Date Effective: March 31, 2022

IFB No. City Project 2163101280-2 Garden Grove Park Improvements - Phase 2

#### INTENT

1. This addendum is issued prior to receipt of bids to provide for modifications in plans and/or specifications. Acknowledgment of this addendum shall be made and cost for work included in proposer's submittal.
2. The following questions were asked regarding the project and the questions and answers are as follows:

#### **Question#1:**

Keynote 8 on sheet L-1 is calling out "Catch Basin Under Surfacing". However on the layout, there was no Keynote 8 indicated. We need the location/s and quantity of these catch basins. Also, there is no bid item allocated for these catch basin unless you want this cost included on bid item 7 - Resilient Play Surfacing. Please clarify.

#### **CONSTRUCTION LEGEND**

- ① 4" THICK CONCRETE PAVING  
FINISH: MEDIUM BROOM  
COLOR: NATURAL GRAY  
REFER TO DETAIL '1', SHEET L-2
- ② RUBBER SURFACING  
REFER TO DETAIL '5', SHEET L-2  
NOTE: WEAR COURSE TO BE 100% COLOR.
- ③ PATHWAY LIGHTS - REFER TO ELECTRICAL SHEETS
- ④ ANGLED BENCH W/ BACK MODEL #424  
COLOR: TIERRA  
TEXTURE: SMOOTH  
AVAILABLE FROM OUTDOOR CREATIONS,  
(530) 338-8367 OR AN APPROVED EQUAL  
REFER TO DETAIL '1', SHEET L-3
- ⑤ CONCRETE PLAY AREA CURB  
REFER TO DETAIL '7', SHEET L-2
- ⑥ 2-5 YEAR PLAYGROUND  
PLAY EQUIPMENT TO BE SELECTED BY  
CONTRACTOR PER SPECIFICATIONS
- ⑦ 5-12 YEAR PLAYGROUND  
PLAY EQUIPMENT TO BE SELECTED BY  
CONTRACTOR PER SPECIFICATIONS
- ⑧ CATCH BASIN UNDER SURFACING  
REFER TO DETAIL '6', SHEET L-2
- ⑨ PIP SURFACING LANDING PATTERN -  
REFER TO DETAIL '2', SHEET L-3

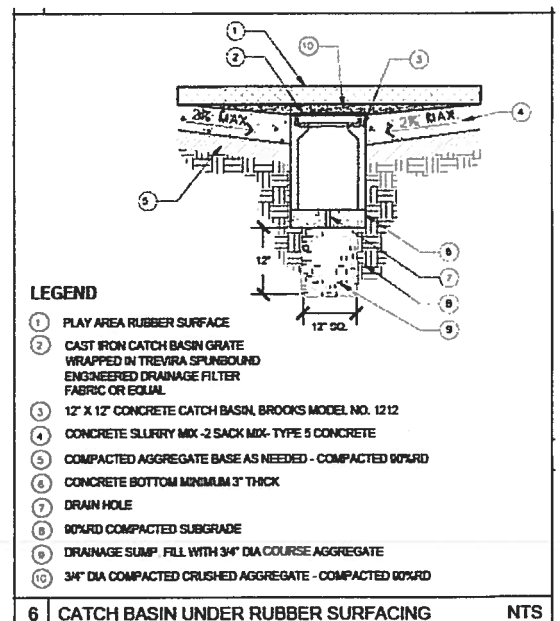

**Answer#1:**

There is to be one Catch Basin for each playground sub-area (generally centered within each space); so a total of two catch basins. The costs for the development of the catch basins is to be inclusive in the bid amount for Bid Item #7: Resilient Play Surfacing & Slurry Base.

**Question#2:**

Please provide the actual color blend(s) for the playground safety surfacing Design – L-1 just states 100% Color.

**Answer#2:**

Play Surfacing colors shall be standard colors, to include:

White/Crème/Eggshell  
Light Grey  
Standard Green

Note: The following surfacing manufacturers have been approved as an Equal for this project:

Spectra Turf;

No Fault Safety Surfacing (NFSS);

Tot Turf by Robertson Recreational Surfaces;

Gotham Poured Rubber

3. Per Page 6 of the bid document, **the bid opening will be teleconferenced; teleconferencing information will be made available at least 7 days ahead of the bid opening date.**

The following is the teleconferencing information for the bid opening that will take place at **11:00 AM, local time, on Monday, April 11, 2022.**

Topic: Garden Grove Park Improvements-Phase 2 City Project No. 2163101280-2  
Time: [Apr 11, 2022 11:00 AM Pacific Time \(US and Canada\)](#)

Join Zoom Meeting

<https://ggcity-org.zoom.us/j/83250572655?pwd=Z2JaMldOSG8rVksrL2dMVXR2dTlqUT09>

Meeting ID: 832 5057 2655

Passcode: 862327

One tap mobile

+16699006833, 83250572655# US (San Jose)

+13462487799, 83250572655# US (Houston)

**Dial by your location**

- +1 669 900 6833 US (San Jose)
- +1 346 248 7799 US (Houston)
- +1 253 215 8782 US (Tacoma)
- +1 301 715 8592 US (Washington DC)
- +1 312 626 6799 US (Chicago)
- +1 929 205 6099 US (New York)

Meeting ID: 832 5057 2655

Find your local number: <https://ggcity-org.zoom.us/j/keHkvLHxtd>

**Join by SIP**

[83250572655@zoomcrc.com](mailto:83250572655@zoomcrc.com)

**Join by H.323**

- 162.255.37.11 (US West)
- 162.255.36.11 (US East)
- 115.114.131.7 (India Mumbai)
- 115.114.115.7 (India Hyderabad)
- 213.19.144.110 (Amsterdam Netherlands)
- 213.244.140.110 (Germany)
- 103.122.166.55 (Australia Sydney)
- 103.122.167.55 (Australia Melbourne)
- 149.137.40.110 (Singapore)
- 64.211.144.160 (Brazil)
- 149.137.68.253 (Mexico)
- 69.174.57.160 (Canada Toronto)
- 65.39.152.160 (Canada Vancouver)
- 207.226.132.110 (Japan Tokyo)
- 149.137.24.110 (Japan Osaka)

Meeting ID: 832 5057 2655

Passcode: 862327

The contractor is hereby notified that Addenda 1, 2 and 3 must be acknowledged and submitted as part of the bid. Failure to do so, could result in the City designating said bid as "Non Responsive". All other terms and conditions of the BID shall remain the same.

Issued by: *Sandra Segawa*  
Sandra Segawa, C.P.M., CPPB  
Purchasing Division Manager  
City of Garden Grove

ADDENDUM No. 4

Covering

CHANGE IN SPECIFICATIONS AND/OR PLANS

Date Issued: April 5, 2022

Date Effective: April 5, 2022

IFB No. City Project 2163101280-2 Garden Grove Park Improvements –  
Phase 2

INTENT

1. This addendum is issued prior to receipt of bids to provide for modifications in plans and/or specifications. Acknowledgment of this addendum shall be made and cost for work included in proposer's submittal.
2. The following question was asked regarding the project and the question and answer is as follows:

**Question:** What is the fall height for 2-5 playground structure and fall Height for 5-12 playground structure? Innovative Playgrounds Company, the playground manufacturer, has provided the following response for this question:

***The CFH for the 5-12 year old playground area is 12 feet and the CFH for the 2-5 playground area is 6 feet.***

The contractor is hereby notified that Addenda 1, 2, 3 and 4 must be acknowledged and submitted as part of the bid. Failure to do so, could result in the City designating said bid as "Non Responsive". All other terms and conditions of the BID shall remain the same.

Issued by: *Sandra Segawa*  
Sandra Segawa, C.P.M., CPPB  
Purchasing Division Manager  
City of Garden Grove