

SECTION 2 - CONTRACTOR'S PROPOSAL

CONTRACTOR'S NAME: _____

THE HONORABLE MAYOR AND CITY COUNCIL
 CITY OF GARDEN GROVE
 11222 ACACIA PARKWAY
 GARDEN GROVE, CALIFORNIA 92840

SUBJECT PROJECT: **GARDEN GROVE PARK IMPROVEMENTS-PHASE 2**
CITY PROJECT NO. 2163101280-2

Potential Bidders:

The undersigned, having carefully examined the Plans and Specifications for the above subject project and having personally visited the site of the work and been made familiar with the conditions, HEREBY PROPOSE to furnish all labor, materials, equipment and transportation, and do all the work required to complete the said work in accordance with the said Plans and Specifications for the unit prices named in the following bid proposal:

BID PROPOSAL

ITEM NO.	APPROX. QUANTITY	ITEM WITH UNIT WRITTEN IN WORDS	UNIT PRICE	ITEM TOTAL
1	300-1.4	1 LS Mobilization (maximum 6%) <u>Seventeen thousand only</u>	<u>\$17,000</u>	<u>\$17,000^{xx}</u>
			Per Lump Sum	
2	300-1.4	1 LS Demolition / Clearing & Grubbing <u>Eighteen thousand only</u>	<u>\$18,000</u>	<u>\$18,000^{xx}</u>
			Per Lump Sum	
3	300-2.9	1 LS Grading <u>Fourteen thousand</u> <u>Five hundred only</u>	<u>\$14,500</u>	<u>\$14,500^{xx}</u>
			Per Lump Sum	
4	303-5.9	720 SF Concrete Paving <u>Fourteen only</u>	<u>\$ 14</u>	<u>\$10,080^{xx}</u>
			Per Square Foot	
5	303-5.9	436 LF Play Area Curb <u>Twenty five only</u>	<u>\$ 25</u>	<u>\$10,900^{xx}</u>
			Per Linear	
6	313-1.1	1 LS Storing & Installing Play Equipment <u>One Hundred</u> <u>Thousand only</u>	<u>\$100,000</u>	<u>\$100,000^{xx}</u>

SECTION 2 – CONTRACTOR'S PROPOSAL ... (continued)

ITEM NO.	APPROX. QUANTITY	ITEM WITH UNIT WRITTEN IN WORDS	UNIT PRICE	ITEM TOTAL
Per Lump Sum				
7	315-1.8	5060 SF Resilient Play Surfacing & Slurry Base <u>Twenty Six only</u>	\$ <u>26</u> -	\$ <u>131,560</u> ^{xx}
Per Square Foot				
8	313-1.1	1 Storing & Installing 2-5 Play Area Shade Canopy <u>Eight thousand only</u>	\$ <u>8,000</u> -	\$ <u>8,000</u> ^{xx}
Per Each				
9	313-1	4 LS Installing Benches <u>Nine Hundred only</u>	<u>900</u> -	\$ <u>3,600</u> ^{xx}
10	316-3	1 LS Electrical Improvements <u>Forty Thousand only</u>	\$ <u>40,000</u> -	\$ <u>40,000</u> ^{xx}
Per Lump Sum				
11	801-8	4,000 Soil Preparation / Fine Grading <u>Three only</u>	\$ <u>3</u> -	\$ <u>12,000</u> ^{xx}
Per Square Foot				

Total Written in Words:

Total in Figures

Three Hundred Sixty Five
Thousand, Six Hundred Forty Dollars \$ 365,640^{xx}

1. The quantities listed for each item in the Proposal Bid Sheets are supplied to give an indication of the general scope of work, but the accuracy of these figures is not guaranteed and the BIDDER shall make his own estimates from the Plans & Specifications. In case of a variation between the Unit Price and the corresponding item Total shown by the BIDDER, the Unit Price shall be considered to be the Bid. The Bidder will be paid for each item by the actual quantity required and installed on the project. The City of Garden Grove reserves the right to increase or decrease the amount of any class or portion of the work as may be deemed necessary or expedient by the Project Manager.

2. The City of Garden Grove desires to construct all improvements within these Plans & Specifications. However, the CITY reserves the right to reject portions or all of the above bid items if sufficient funds are not available, or the CITY determines it is not in the CITY's best interest to award the Contract.

NOTES:

1. In case of discrepancy between the words and figures, the words shall prevail.
2. The aforementioned quantities are approximate only, being given as a basis for the comparison of bids, and the City of Garden Grove does not expressly or by implication, agree that the actual amount of work will correspond therewith, but reserves the right to increase or decrease the amount of any class or portion of work as may be deemed necessary or expedient by the Project Manager.

It is understood and agreed that:

(a) Pursuant to Section 1773.2 of the Labor Code, general prevailing wage rates established by the Director of the Department of Industrial Relations shall be posted by the Contractor at a prominent place at the site of the work.

The Federal Davis-Bacon Act prevailing wages apply to the work. If there is a difference in the minimum wage rate predetermined by the Secretary of Labor and the prevailing wage rates determined by the Director of Industrial Relations, for similar classifications of labor, the Contractor and its subcontractors shall pay not less than the highest wage rate.

(b) No verbal agreement or conversation with any officer, agent or employee of CITY, either before or after the execution of the Agreement shall affect or modify any of the terms or obligations of this Proposal.

(c) CITY will not be responsible for any errors or omissions on the part of the undersigned in making up their bid, nor will bidders be released because of errors.

(d) The undersigned is licensed in accordance with the laws of the State of California.

(e) The undersigned hereby certifies that this Proposal is genuine and is not sham or collusive, or made in the interest or on behalf of any person not herein named, and that the undersigned has not directly or indirectly induced or solicited any other bidder to put in a sham bid; or any other person, firm or corporation to refrain from bidding, that the undersigned has not in any manner sought, by collusion, to secure for itself an advantage over any other bidder and that the unit prices proposed herein shall remain fully in effect for 180 calendar days from bid opening.

I declare under penalty of perjury that all statements or representations made herein are true and correct.

DATE: 4/18/2022

Deark EJC Inc.
BIDDER'S NAME

[Signature]
AUTHORIZED SIGNATURE

Corporation
TYPE OF ORGANIZATION: INDIVIDUAL,
PARTNERSHIP OR CORPORATION

1830 W. 147th St. Gardena, CA 90249
ADDRESS

424-344-2380
TELEPHONE FAX

01/31/2023
EXPIRATION DATE

1059536
STATE OF CALIFORNIA LICENSE NUMBER

SECTION 3 - DESIGNATION OF SUBCONTRACTORS/REFERENCES

1. The undersigned certifies that the sub-bids of the following listed subcontractors have been used in making up this bid, and that the subcontractors listed will be used for the work for which they bid, subject to the approval of the Community Services Manager, and in accordance with the applicable provisions of the Specifications.

Bidder's Full and Legal Name

Deank E & C Inc.

PART I

The bidder shall list all subcontractors (both DBE and non-DBE) in pursuant to Public Contract Code Sections §4104 of California Public Contract Code. This listing is required in addition to listing DBE Subcontractors elsewhere in the proposal. Photocopy this form for additional firms.

Firm Name/LICENSE NUMBER Address/ City, State, ZIP	Phone/ Fax	Annual Gross Receipts	Description of items of Work to be Performed	Local Agency Use Only (Certified DBE?) <input type="checkbox"/> YES <input type="checkbox"/> NO If YES list DBE #:
Name SPECTRATURF	Phone 951-736-3579	<input type="checkbox"/> < \$1 million <input type="checkbox"/> < \$5 million <input type="checkbox"/> < \$10 million <input checked="" type="checkbox"/> < \$15 million <input type="checkbox"/> > \$15 million	PROVIDE & INSTALL PLAYGROUND SAFETY SURFACING	<input type="checkbox"/> YES <input type="checkbox"/> NO If YES list DBE #:
Address 555 S. PROMENADE AVE. #103	Fax 951-734-3630			Age of Firm (Mrs.)
City State ZIP CORONA, CA 92879				<input type="checkbox"/> YES <input type="checkbox"/> NO If YES list DBE #:
Name Vepetric Technologies Inc.	Phone 951-538-8414	<input checked="" type="checkbox"/> < \$1 million <input type="checkbox"/> < \$5 million <input type="checkbox"/> < \$10 million <input type="checkbox"/> < \$15 million <input type="checkbox"/> > \$15 million	provide Electrical Service	<input type="checkbox"/> YES <input type="checkbox"/> NO If YES list DBE #:
Address 2407 Baltimore Ave. Menlo Valley	Fax			Age of Firm (Mrs.)
City State ZIP Menlo Valley CA 95557				<input type="checkbox"/> YES <input type="checkbox"/> NO If YES list DBE #:
Name	Phone	<input type="checkbox"/> < \$1 million <input type="checkbox"/> < \$5 million <input type="checkbox"/> < \$10 million <input type="checkbox"/> < \$15 million <input type="checkbox"/> > \$15 million		<input type="checkbox"/> YES <input type="checkbox"/> NO If YES list DBE #:
Address	Fax			Age of Firm (Mrs.)
City State ZIP				<input type="checkbox"/> YES <input type="checkbox"/> NO If YES list DBE #:
Name	Phone	<input type="checkbox"/> < \$1 million <input type="checkbox"/> < \$5 million <input type="checkbox"/> < \$10 million <input type="checkbox"/> < \$15 million <input type="checkbox"/> > \$15 million		<input type="checkbox"/> YES <input type="checkbox"/> NO If YES list DBE #:
Address	Fax			Age of Firm (Mrs.)
City State ZIP				<input type="checkbox"/> YES <input type="checkbox"/> NO If YES list DBE #:
Name	Phone	<input type="checkbox"/> < \$1 million <input type="checkbox"/> < \$5 million <input type="checkbox"/> < \$10 million <input type="checkbox"/> < \$15 million <input type="checkbox"/> > \$15 million		<input type="checkbox"/> YES <input type="checkbox"/> NO If YES list DBE #:
Address	Fax			Age of Firm (Mrs.)
City State ZIP				<input type="checkbox"/> YES <input type="checkbox"/> NO If YES list DBE #:

PART II

The bidder shall list all subcontractors who provided a quote or bid but were not selected to participate as a subcontractor on this project. This is required for compliance with Public Contract Code Sections §4104 of California Public Contract Code. Photocopy this form for additional firms.

Firm Name/ Address/ City, State, ZIP	Phone/ Fax	Annual Gross Receipts	Description of items of Work to be Performed	Local Agency Use Only (Certified DBE?)
Name	Phone	<input type="checkbox"/> < \$1 million <input type="checkbox"/> < \$5 million <input type="checkbox"/> < \$10 million <input type="checkbox"/> < \$15 million <input type="checkbox"/> > \$15 million		<input type="checkbox"/> YES <input type="checkbox"/> NO if YES list DBE #
Address	Fax			Age of Firm (Yrs.)
City State ZIP				
Name	Phone	<input type="checkbox"/> < \$1 million <input type="checkbox"/> < \$5 million <input type="checkbox"/> < \$10 million <input type="checkbox"/> < \$15 million <input type="checkbox"/> > \$15 million		<input type="checkbox"/> YES <input type="checkbox"/> NO if YES list DBE #
Address	Fax			Age of Firm (Yrs.)
City State ZIP				
Name	Phone	<input type="checkbox"/> < \$1 million <input type="checkbox"/> < \$5 million <input type="checkbox"/> < \$10 million <input type="checkbox"/> < \$15 million <input type="checkbox"/> > \$15 million		<input type="checkbox"/> YES <input type="checkbox"/> NO if YES list DBE #
Address	Fax			Age of Firm (Yrs.)
City State ZIP				
Name	Phone	<input type="checkbox"/> < \$1 million <input type="checkbox"/> < \$5 million <input type="checkbox"/> < \$10 million <input type="checkbox"/> < \$15 million <input type="checkbox"/> > \$15 million		<input type="checkbox"/> YES <input type="checkbox"/> NO if YES list DBE #
Address	Fax			Age of Firm (Yrs.)
City State ZIP				

SECTION 4 – AFFIDAVIT TO ACCOMPANY PROPOSAL

USE THIS FORM WHEN BIDDER IS AN INDIVIDUAL

State of California)
County of Orange) ss.

(Name) X/A Affiant,
being first duly sworn, deposes and says:

That it is the bidder who makes the accompanying proposal; that such proposal is genuine, and not sham or collusive, nor made in the interest or on behalf of any person not herein named, and that the bidder has not directly or indirectly induced or solicited any other bidder to put in a sham bid, or any other person, firm or corporation to refrain from bidding, and that the bidder has not in any manner sought by collusion to secure for itself an advantage over any other bidder.

Subscribed and sworn to before me _____

This _____ day of _____, 20____.

Signature: _____

Notary Public in and for the County of _____, State of _____

USE THIS FORM WHEN BIDDER IS A CORPORATION

State of California)
County of Orange) ss.

Beak K Jeong affiant, the Project Manager
of Deark E & C Inc. Pres., Sec., or Mgr. Ofcr
Name of Corporation

The corporation who makes the accompanying proposal, having first been duly sworn, deposes and says: That such proposal is genuine and not sham or collusive, nor made in the interest or on behalf of any person not herein named, and that the bidder has not directly or indirectly induced or solicited any other bidder to put in a sham bid, or any other person, firm or corporation to refrain from bidding, and that the bidder has not in any manner sought by collusion to secure for itself an advantage over any other bidder.

[Signature]
Signature
President, Secretary or Managing Officer

Subscribed and sworn to before me _____

This _____ day of attached, 20____.

Notary Public in and for the County of _____, State of _____

Signature: sel _____

CALIFORNIA JURAT WITH AFFIANT STATEMENT

- See Attached Document (Notary to cross out lines 1 – 6 below)
 See Statement Below (Lines 1 – 5 to be completed only by document signer(s), *not* Notary)

1. _____
2. _____
3. _____
4. _____
5. _____
6. _____

Signature of Document Signer No. 1 _____ Signature of Document Signer No. 2 _____

A notary public or other officer completing this certificate verifies only the identity of the individual who signed the document to which this certificate is attached, and not the truthfulness, accuracy or validity of that document.

State of California
County of Los Angeles)

Subscribed and sworn to (or affirmed) before me on this 8 day of April, 2022, by
Beak K Jeong, proved to me on the basis of satisfactory evidence to be the person who appeared before me (.) (.)

(and

_____, proved to me on the basis of satisfactory evidence to be the person who appeared before me.)

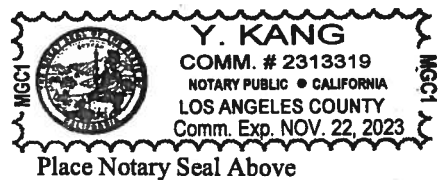

Signature: [Handwritten Signature]

OPTIONAL

Though the information below is not required by law, it may prove valuable to persons relying on the document and could prevent fraudulent removal and reattachment of this form to another document.

Further Description of Any Attached Document:
Title or Type of Document: _____
Document Date: _____ Number of Pages: _____
Signer(s) Other Than Named Above: _____

RIGHT THUMBPRINT OF SIGNER #1

Top of Thumb Here

RIGHT THUMBPRINT OF SIGNER #2

Top of Thumb Here

SECTION 4 – AFFIDAVIT TO ACCOMPANY PROPOSAL (Continued)

USE THIS FORM WHEN BIDDER IS A CO-PARTNERSHIP

State of California)
County of Orange) ss.

_____ *N/A* _____, Affiant(s),
Being first duly sworn, each for itself deposes and says:

That _____
(Names of all Partners)

are partners, doing business under the firm name and style of

_____ and that said co-partnership
(Name of Firm)

makes the accompanying proposal; that such proposal is genuine, and not sham or collusive, nor made in the interest or on behalf of any person not herein named, and that the bidder has not directly or indirectly induced or solicited any other bidder to put in a sham bid, or any other person, firm or corporation to refrain from bidding, and that the bidder has not in any manner sought by collusion to secure for itself an advantage over any other bidder.

Subscribed and sworn to before me _____

This _____ day of _____, 20____.

Notary Public in and for the County of _____,
State of _____

Signature: _____

SECTION 4 – AFFIDAVIT TO ACCOMPANY PROPOSAL (Continued)

CERTIFICATION WITH REGARD TO THE PERFORMANCE OF PREVIOUS CONTRACTS OR SUBCONTRACTS SUBJECT TO THE EQUAL EMPLOYMENT OPPORTUNITY CLAUSE AND THE FILING OF REQUIRED REPORTS

The bidder X, proposed subcontractor _____, hereby certifies that he has X, has not _____, participated in a previous contract or subcontract subject to the equal opportunity clause, as required by Executive Orders 10925, 11114, or 11246, and that he has X, has not _____, filed with the Joint Reporting Committee, the Director of the Office of Federal Contract Compliance, a Federal Government contracting or administrating agency, or the former President's Committee on Equal Employment Opportunity, all reports due under the applicable filing requirements.

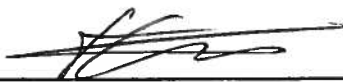
By: 
Benk K Jeong
(Title)

Date: 4/8/2022

Note: The above certification is required by the Equal Employment Opportunity Regulations of the Secretary of Labor (41 CFR 60-1.7 (b) (1)), and must be submitted by bidders and proposed subcontractors only in connection with contracts and subcontracts, which are subject to the equal opportunity clause. Contracts and subcontracts which are exempt from the equal opportunity clause are set forth in 41 CFR 60-1.5. (Generally, only contracts or subcontracts of \$10,000 or under are exempt.)

Currently, Standard Form 100 (EEO-1) is the only report required by the Executive Orders or their implementing regulations.

Proposed prime contractors and subcontractors who have participated in a previous contract or subcontract subject to the Executive Orders and have not filed the required reports should note that 41 CFR 60-1.7 (b) (1) prevents the award of contracts and subcontracts unless such contractor submits a report covering the delinquent period or such other period specified by the Federal Highway Administration or by the Director, Office of Federal Contract Compliance, U.S. Department of Labor.

(THE BIDDER'S EXECUTION ON THE SIGNATURE PORTION OF THIS PROPOSAL SHALL ALSO CONSTITUTE AN ENDORSEMENT AND EXECUTION OF THOSE CERTIFICATIONS WHICH ARE A PART OF THIS PROPOSAL)

EQUAL EMPLOYMENT OPPORTUNITY CERTIFICATION

The bidder Deark E & C Inc.

[proposed subcontractor,] hereby certifies that he/she/it has, has not, participated in a previous contract or subcontract subject to the Equal Opportunity clauses, as required by Executive Orders 10925, 11114, or 11246, and that, where required, he/she/it has filed with the Joint

Reporting Committee, the Director of the Office of Federal Contract Compliance, a Federal Government contracting or administering agency, or the former President's Committee on Equal Employment Opportunity, all reports due under the applicable filing requirements.

Note: The above certification is required by the Equal Employment Opportunity Regulations of the Secretary of Labor (41 CFR 60-1.7(b) (1)), and must be submitted by bidders and proposed subcontractors only in connection with contracts and subcontracts which are subject to the equal opportunity clause. Contracts and subcontracts which are exempt from the equal opportunity clause are set forth in 41 CFR 60-1.5. (Generally only contracts or subcontracts of \$ 10,000 or under are exempt.)

Currently, Standard Form 100 (EEO-I) is the only report required by the Executive Orders or their implementing regulations. (eeoc.gov/employers/eeol_survey/index.cfm)

Proposed prime contractors and subcontractors who have participated in a previous contract or subcontract subject to the Executive Orders and have not filed the required reports should note that 41 CFR 60-1.7(b) (1) prevents the award of contracts and subcontracts unless such contractor submits a report covering the delinquent period or such other period specified by the Federal Highway Administration or by the Director, Office of Federal Contract Compliance, U.S. Department of Labor.

Signature:  Date: 4/8/2022

Print Name: Beak K Jeong

Title: Project Manager

Equal Employment Opportunity Clause

During the performance of this contract, the Contractor agrees as follows:

- (a) The Contractor shall not discriminate against any employee or applicant for employment because of race, color, religion, sex, national origin, or handicap.
- (b) The Contractor shall take affirmative action to ensure that applicants are employed, and that employees are treated during employment without regard to their race, color, religion, sex, national origin, or handicap. Such action shall include, but not be limited to, (1) employment, (2) upgrading, (3) demotion, (4) transfer, (5) recruitment or recruitment advertising, (6) layoff or termination, (7) rates of pay or other forms of compensation, and (8) selection for training, including apprenticeship.
- (c) The Contractor shall post in conspicuous places available to employees and applicants for employment the notices to be provided by the Contracting Officer that explain this clause.
- (d) The Contractor shall, in all solicitations or advertisements for employees placed by or on behalf of the Contractor, state that all qualified applicants will receive consideration for employment without regard to race, color, religion, sex, national origin, or handicap.
- (e) The Contractor shall send, to each labor union or representative of workers with which it has a collective bargaining agreement or other contract or understanding, the notice to be provided by the Contracting Officer advising the labor union or workers' representative of the Contractor's commitments under this clause, and post copies of the notice in conspicuous places available to employees and applicants for employment.
- (f) The Contractor shall comply with Executive Order 11246, as amended, and the rules, regulations, and orders of the Secretary of Labor.
- (g) The Contractor shall furnish all information and reports required by Executive Order 11246, as amended, Section 503 of the Rehabilitation Act of 1973, as amended, and by rules, regulations, and orders of the Secretary of Labor, or pursuant thereto. The Contractor shall permit access to its books, records, and accounts by the Secretary of Labor for purposes of investigation to ascertain compliance with such rules, regulations, and orders.
- (h) In the event of a determination that the Contractor is not in compliance with this clause or any rule, regulation, or order of the Secretary of Labor, this contract may be canceled, terminated, or suspended in whole or in part, and the Contractor may be declared ineligible for further Government contracts, or Federally assisted construction contracts under the procedures authorized in Executive Order 11246, as amended. In addition, sanctions may be imposed and remedies invoked against the Contractor as provided in Executive Order 11246, as amended, the rules, regulations, and orders of the Secretary of Labor, or as otherwise provided by law.
- (i) The Contractor shall include the terms and conditions of this clause in every subcontract or purchase order unless exempted by the rules, regulations, or orders of the Secretary of Labor issued under Executive Order 11246, as amended, so that these terms and conditions will be binding upon each subcontractor or vendor. The Contractor shall take such action with respect to any subcontract or purchase order as the Secretary of Housing and Urban Development or the Secretary of Labor may direct as a means of enforcing such provisions, including sanctions for noncompliance; provided that if the Contractor becomes involved in, or is threatened with, litigation with a subcontractor or vendor as a result of such direction, the Contractor may request the United States to enter into the litigation to protect the interests of the United States.
- (j) Compliance with the requirements of this clause shall be to the maximum extent consistent with, but not in derogation of, compliance with section 7(b) of the Indian Self-Determination and Education Assistance Act and the Indian Preference clause of this contract.

PUBLIC CONTRACT CODE

Public Contract Code Section 10285.1 Statement

In conformance with Public Contract Code Section 10285.1 (Chapter 376, Stats. 1985), the bidder hereby declares

Under penalty of perjury under the laws of the State of California that the bidder has ____, has not X been convicted within the preceding three years of any offenses referred to in that section, including any charge of fraud, bribery, collusion, conspiracy, or any other act in violation of any state or Federal antitrust law in connection with the bidding upon, award of, or performance of, any community services contract, as defined in Public Contract Code Section 1101, with any public entity, as defined in Public Contract Code Section 1100, including the Regents of the University of California or the Trustees of the California State University. The term "bidder" is understood to include any partner, member, officer, director, responsible managing officer, or responsible managing employee thereof, as referred to in Section 10285.1.

Note: The bidder must place a checkmark after "has" or "has not" in one of the blank spaces provided. The above Statement is part of the Proposal. Signing this Proposal on the signature portion thereof shall also constitute signature of this Statement. Bidders are cautioned that making a false certification may subject the certifier to criminal prosecution.



Public Contract Code Section 10162 Questionnaire

In conformance with Public Contract Code Section 10162, the Bidder shall complete, under penalty of perjury, the following questionnaire:

Has the bidder, any officer of the bidder, or any employee of the bidder who has a proprietary interest in the bidder, ever been disqualified, removed, or otherwise prevented from bidding on, or completing a federal, state, or local government project because of a violation of law or a safety regulation?

Yes ____ No X

If the answer is yes, explain the circumstances in the following space.

Public Contract Code 10232 Statement

In conformance with Public Contract Code Section 10232, the Contractor, hereby states under penalty of perjury, that no more than one final unappealable finding of contempt of court by a federal court has been issued against the Contractor within the immediately preceding two-year period because of the Contractor's failure to comply with an order of a federal court which orders the Contractor to comply with an order of the National Labor Relations Board.

Note: The above Statement and Questionnaire are part of the Proposal. Signing this Proposal on the signature portion thereof shall also constitute signature of this Statement and Questionnaire.

Bidders are cautioned that making a false certification may subject the certifier to criminal prosecution.

A handwritten signature in black ink, consisting of several loops and a long horizontal stroke, positioned above a solid horizontal line.

Noncollusion Affidavit
(Title 23 United States Code Section 112 and
Public Contract Code Section 7106)

[NAME OF CONTRACT] Deank E & C Inc.

To the City of Garden Grove
DEPARTMENT OF COMMUNITY SERVICES.

In conformance with Title 23 United States Code Section 112 and California Public Contract Code 7106 the bidder declares that the bid is not made in the interest of, or on behalf of, any undisclosed person, partnership, company, association, organization, or corporation; that the bid is genuine and not collusive or sham; that the bidder has not directly or indirectly induced or solicited any other bidder to put in a false or sham bid, and has not directly or indirectly colluded, conspired, connived, or agreed with any bidder or anyone else to put in a sham bid, or that anyone shall refrain from bidding; that the bidder has not in any manner, directly or indirectly, sought by agreement, communication, or conference with anyone to fix the bid price of the bidder or any other bidder, or to fix any overhead, profit, or cost element of the bid price, or of that of any other bidder, or to secure any advantage against the public body awarding the contract of anyone interested in the proposed contract; that all statements contained in the bid are true; and, further, that the bidder has not, directly or indirectly, submitted his or her bid price or any breakdown thereof, or the contents thereof, or divulged information or data relative thereto, or paid, and will not pay, any fee to any corporation, partnership, company association, organization, bid depository, or to any member or agent thereof to effectuate a collusive or sham bid.

Note: The above Noncollusion Affidavit is part of the Bidder's Proposal. By signing the Proposal, the Bidder has also signed this Noncollusion Affidavit.

Bidders are cautioned that making a false Certification may subject the Bidder to criminal prosecution.

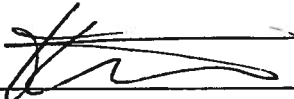
Signature:  Date: 4/8/2022

Print Name: Beak K Teong

Title: Project Manager

SECTION 4 B - QUESTIONNAIRE TO GENERAL CONTRACTORS

1. Has any person or group threatened you with subcontractor boycotts, union boycotts, or other sanctions to attempt to convince you to use the services or abide by the rules of one or more bid depositories?

Yes ()

No (X)

2. If the answer to No. 1 is "yes," please explain the following details:

(a) Date(s):

(b) Name of person or group:

(c) Job involved (if applicable):

(d) Nature of threats:

(e) Additional comments:
(Use additional paper if necessary)

We declare under penalty of perjury that the foregoing is true and correct.

Dated this 8 day of 4, 2022.

Deark E & C Inc
Name of Company

By [Signature]

Project Manager
Title

SECTION 4 B - QUESTIONNAIRE TO GENERAL CONTRACTORS (Continued)

QUESTIONNAIRE REGARDING BIDDERS

Number of years engaged in the contracting business under present business name 5.

List of last three contracts performed which show experience in work of a nature similar to that covered in this proposal. If none, so indicate.

<u>Year</u>	<u>Type of Work</u>	<u>Contract Amt.</u>	<u>Location</u>	<u>For whom Performed & Phone Number</u>
2020	Restroom Remodeling	100,000	Santa Barbara	Michael Ruben 805 260 8245
2020	Hardscaping & Landscaping	450,000	Santa Barbara	Michael Ruben 805 260 8245
2020	Transportation ADA Upgrade	167,000	Palmdale	Ulises Gonzalez 661 267 541

REFERENCES:

Following are the names, addresses and telephone numbers of firms or agencies with which you may confirm the past performances of the company in performing work of a similar nature and scope:

<u>Firm/Address</u>	<u>Type of Work</u>	<u>Contact Person Telephone No.</u>	<u>Contract Amount</u>
City of Lakewood	Park Improvement	Duane 562 900 6200	737,000
O.C. Sanitation District	Park Improvement	Vince Proctor 714 856 8465	427,400
Gardena 1717 W. 162nd St.	New public Restroom in park	Jose Espinoza 310 217 9644	105,550

Bidder's Name: Deark E & C Inc

Authorized Signature: [Signature] Date: 4/8/2022

State of California Contractor's License No. 1059536

Contractor's License Expiration Date 10/31/2022

DIR Registration Number and Expiration Date 1000579126

SECTION 4 C - CONTRACTOR'S QUESTIONNAIRE

1. List any lawsuit(s) filed against you or your firm over the past ten (10) years for breach or non-performance of contract:

N/A

2. List the results of any lawsuit(s):

N/A

3. List any claim(s) filed by subcontractors against you or your firm over the past ten (10) years:

N/A

4. List the results of each claim:

N/A

5. List any disciplinary action and the ultimate disposition within the past ten (10) years taken against you or your firm by the State Contractor's License Board:

N/A

6. List projects similar to the type applied for herein which you have worked on and how recently the project was performed:

N/A

I DECLARE UNDER PENALTY OF PERJURY THAT THE FOREGOING IS TRUE, COMPLETE, ACCURATE, AND CORRECT.

Dated: 4/8/2022



Contractor's Signature

Accompanying this Bid is

(NOTICE: INSERT THE WORDS "CASH (\$ _____)," "CASHIER'S CHECK,"
"CERTIFIED CHECK," OR "BIDDER'S BOND," AS THE CASE MAY BE.)

in amount equal to at least ten percent of the total of the bid.

The names of all persons interested in the foregoing bid as principals are as follows:

IMPORTANT NOTICE

If bidder or other interested person is a corporation, state legal name of corporation, also names of the president, secretary, treasurer, and manager thereof; if a co-partnership, state true name of firm, also names of all individual copartners composing firm; if bidder or other interested person is an individual, state first and last names in full.

Licensed in conformance with an act providing for the registration of Contractors,

License No. 1059536 Classification(s) A, B

ADDENDA -

This Bid is submitted with respect to the changes to the contract included in addenda number/s 4

(Fill in addenda numbers if addenda have been received and insert, in this Bid, any Project Manager's Estimate sheets that were received as part of the addenda.)

By my signature on this bid I certify, under penalty of perjury under the laws of the State of California, that the foregoing questionnaire and statements of Public Contract Code Sections 10162, 10232 and 10285.1 are true and correct and that the bidder has complied with the requirements of Section 8103 of the Fair Employment and Housing Commission Regulations (Chapter 5, Title 2 of the California Administrative Code). By my signature on this Bid I further certify, under penalty of perjury under the laws of the State of California and the United States of America, that the Non collusion Affidavit required by Title 23 United States Code, Section 112 and Public Contract Code Section 7106; and the Title 49 Code of Federal Regulations, Part 29 Debarment and Suspension Certification are true and correct.

Date: 4/18/2022



[Signature]
Project Manager
Beak K Jeong

Signature and Title of Bidder

Business Address 1830 W. 147th St. Gardena, CA 90249

Place of Business Gardena, California

Place of Residence Artesia, California

**BIDDER/CONTRACTOR/CONSULTANT STATEMENT
REGARDING INSURANCE COVERAGE
(Submit with IFB/RFP Package)**

This signed document must be included with your bid/proposal package in order for your bid/proposal to be considered complete!

BIDDER/CONTRACTOR/CONSULTANT HEREBY CERTIFIES that he/she has reviewed and understands the insurance coverage requirements specified in the attached Insurance Requirements Checklist.

Should we/I be awarded the contract, we/I certify that we/I can meet the specified requirements for insurance, including insurance coverage of the subcontractors, and agree to name the **City/Successor Agency/Sanitary District** and other additional insureds as per the agreement for the work specified and we/I will comply with the provisions of Section 3700 of the Labor Code, which require every employer to be insured against liability for worker's compensation or to undertake self-insurance in accordance with the provisions of that code, before commencing the performance of the work specified.

Deark E & C Inc.

Please Print (Person, Firm, or Corporation)



Signature of Authorized Representative

Beak K Jeong / Project Manager

Please Print (Name & Title of Authorized Representative)

4/8/2022 424-344-2380 peter@dearkec.ca

Date

Phone Number

Email

Please note that the City of Garden Grove is now contracted with EBIX for insurance certificate management and review services. EBIX will collect the insurance requirements in the contract on behalf of the City. If you are awarded the contract, you will be contacted by EBIX regarding the insurance requirements listed in this bid in the sample contract. Please forward all insurance documents to EBIX directly per their instructions when contacted.

NOTE: All insurance certificates and endorsements must be received by or sent to EBIX within ten (10) City working days of the original request or the City reserves the right to proceed with the next lowest responsible bidder or the next highest scoring proposer in the process. Please do not send any insurance documents to the City but please use the following email address to send insurance documents to Ebix directly: ggcity@ebix.com.



STATEMENT OF COMPLIANCE

The undersigned Proposer declares that the bid submitted to Furnish all Labor, Material, Tools and Equipment for the Furnish all Labor, Material, Tools, Equipment and Incidentals for the Garden Grove Park Improvements Project-Phase 2, per the bid specifications as described in, and in response to City of Garden Grove IFB No. 2163101280-2 was prepared in strict compliance with the instructions, conditions and terms listed in the IFB, Scope of Work/Bid Specifications and Sample Agreement, with exceptions listed below, if applicable. At least one box for each item must be checked.

IFB Instructions and Terms & Conditions (Check One)

No Exceptions Taken Exceptions Taken

Scope of Work/Bid Specifications (Check One)

No Exceptions Taken Exceptions Taken

Draft Agreement/Insurance Requirements (Check One)

No Exceptions Taken Exceptions Taken

If any exceptions are taken, this Statement of Compliance shall include a narrative that identifies each item to which the Proposer is taking exception or is recommending change, including the suggested rewording of the contractual obligations or suggested change in IFB, and identifies the reasons for submitting the proposed exception or change. When available, please reference specific line item numbers as provided in the RFP. The City reserves the right to rule as non-responsive and reject any bids that are not accompanied with the required documentation as described above.

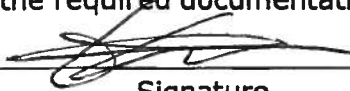

Signature

Beak K Jeong

Printed Name and Title

4/2/2022

Date

Peak E&O Inc.

Name of Proposer

SAMPLE CONSTRUCTION AGREEMENT

THIS AGREEMENT is made this 8 day of April, 2022 by the CITY OF GARDEN GROVE, a municipal corporation, ("CITY"), and Deank E&C Inc., hereinafter referred to as ("CONTRACTOR").

CITY desires to utilize the services of CONTRACTOR to furnish material, equipment, and labor for the **GARDEN GROVE PARK IMPROVEMENTS-PHASE 2, CITY PROJECT NO. 2163101280-2.**

CONTRACTOR is qualified by virtue of experience, training, education, and expertise to accomplish services.

WHEREAS, CITY has solicited bids for a capital improvement project, hereinafter referred to as "PROJECT," more fully described as GARDEN GROVE PARK IMPROVEMENTS-PHASE 2, CITY PROJECT NO. 2163101280-2., in the City of Garden Grove; and

CONTRACTOR has been selected to perform said services,

NOW, THEREFORE, in consideration of the promises and agreements hereinafter made and exchanged, the parties covenant and agree as follows:

1. STATEMENT OF WORK ACCEPTANCE OF RISK

CONTRACTOR shall complete and construct the PROJECT pursuant to this Agreement and the Contract Documents (as hereinafter defined) and furnish, at its own cost and expense, all labor, plans, tools, equipment, supplies, transportation, utilities and all other items, services and facilities necessary to complete and construct the PROJECT in a good and workmanlike manner.

CONTRACTOR agrees to fully assume the risk of all loss or damage arising out of the nature of the PROJECT, during its progress or prior to acceptance by CITY, from the action of the elements, from any unforeseen difficulties which may arise or be encountered in the prosecution of work, and for all other risks of any description in connection with the work, including, but not limited to, all expenses incurred by or in consequence of the suspension or discontinuance of work, except such as are herein expressly stipulated to be borne by CITY, and for well and faithfully completing the work within the stipulated time and in the manner shown and described in this Agreement, and in accordance with the requirements of CITY for the compensation set forth in the accepted bid proposal.

2. ACCEPTANCE OF CONDITIONS OF WORK PLANS AND SPECIFICATIONS

CONTRACTOR acknowledges that it is fully familiar with all the terms, conditions and obligations of this Agreement and the Contract Documents (as defined below in this Section), the location of the job site, and the conditions under which the work is to be performed, and that it enters into this Agreement based upon its thorough investigation of all such matters and is relying in no way upon any opinions or representations of CITY.

It is agreed that the Contract Documents are incorporated into this Agreement by this reference, with the same force and effect as if the same were set forth at length herein, and that CONTRACTOR and its subcontractors, if any, shall be bound by the Contract Documents insofar as they relate in part or in any way, directly or indirectly, to the work covered by this Agreement.

"Contract Documents" as defined herein mean and include:

- A. This Agreement;
- B. Bonds covering the work herein agreed upon;
- C. The particular Plans, Specifications, Special Provisions and Addenda applicable to the PROJECT. Anything mentioned in the Specifications and not indicated in the Plans or indicated in the Plans and not mentioned in the Specifications, shall be of like effect as if indicated and mentioned in both. In case of a discrepancy between any Plans, Specifications, Special provisions, or Addenda, the matter shall be immediately submitted by CONTRACTOR to the Department of Community Services of CITY (hereinafter referred to as "DCS"), and CONTRACTOR shall not attempt to resolve or adjust the discrepancy without the decision of DCS, save only at its own risk and expense.

Should there be any conflict between the terms of this Agreement and the bid or proposal of CONTRACTOR, then this Agreement shall control and nothing herein shall be considered as an acceptance of the terms of the bid or proposal which is in conflict herewith.

3. COMPENSATION

CITY agrees to pay and CONTRACTOR agrees to accept as full compensation for the faithful performance of this Agreement, subject to any additions or deductions made under the provisions of this Agreement or the Contract Documents, a sum not to exceed **Dollars \$ 365,640.00** **(xxxxxxx.xx)**, as set forth in the Contract Documents, to be paid as provided in this Agreement.

4. COMMENCEMENT OF PROJECT

CONTRACTOR agrees to commence the PROJECT within ten (10) working days after the Notice to Proceed is issued and diligently prosecute the PROJECT to completion within **Forty (40) working days** from the day the Notice to Proceed is issued by DCS, excluding delays provided for in this Agreement.

5. TIME OF THE ESSENCE

The parties hereto recognize and agree that time is of the essence in the performance of this Agreement and each and every provision of the Contract Documents.

CONTRACTOR shall prepare and obtain approval as required by the Contract Documents for all shop drawings, details and samples, and do all other things necessary and incidental to the prosecution of its work in conformance with the progress schedule set forth in the Contract Documents. CONTRACTOR shall coordinate its work with the work of all other contractors, subcontractors, and CITY forces working on the PROJECT in a manner that will facilitate the efficient completion of the PROJECT and in accordance with the terms and provisions of this Agreement. CITY shall have complete control of the premises on which the work is to be performed and shall have the right to decide the time and order in which the various portions of the work shall be performed and the priority of the work of other contractors, subcontractors and CITY forces and, in general, all matters concerning the timely and orderly conduct of the work of CONTRACTOR on the premises.

6. CHANGES

CONTRACTOR shall adhere strictly to the plans and specifications set forth in the Contract Documents unless a change therefrom is authorized in writing by DCS. CONTRACTOR agrees to make any and all changes, furnish materials and perform all work necessary within the scope of the PROJECT as DCS may require in writing. Under no condition shall CONTRACTOR make any changes

without the prior written order or acceptance of DCS, and CITY shall not pay any extra charges made by CONTRACTOR that have not been agreed upon in writing by DCS.

When directed to change the work, CONTRACTOR shall submit immediately to DCS a written cost proposal reflecting the effect of the change. Should DCS not agree to such cost proposal, the work shall be performed according to the changes ordered in writing by DCS and the proper cost thereof shall be negotiated by the parties upon cost and pricing data submitted by CONTRACTOR; thereupon, CITY will promptly issue an adjusted change order to CONTRACTOR and the Agreement price will be adjusted upward or downward accordingly.

7. NOTICE TO PROCEED

No work, services, material, or equipment shall be performed or furnished under this Agreement unless and until a Notice to Proceed has been given to CONTRACTOR by CITY. CITY does not warrant that the work will be available on the date the Notice to Proceed is issued. In the event of a delay in commencement of the work due to unavailability of the job site, for any reason, relief to CONTRACTOR shall be limited to a time extension equal to the delay due to such unavailability.

8. BONDS

CONTRACTOR shall, prior to entering into performance of this Agreement, furnish a performance bond, on the CITY's bond form in the amount of one hundred percent (100%) of the Contract price, to guarantee the faithful performance of the work, and a payment bond, on the CITY's form in the amount of one hundred percent (100%) of the Contract price, to guarantee payment of all claims for labor and materials furnished. Bonds submitted on any form other than the CITY's form will be rejected. The required bonds shall be from a surety licensed to do business in the State of California and with a current A.M. Best's rating of A-, VII. This Contract shall not become effective until such bonds are supplied and approved by the CITY.

In addition, CONTRACTOR shall submit to CITY a bond in the amount of one hundred percent (100%) of the final Agreement price, including all change orders, to warrant such performance for a period of one (1) year after CITY's acceptance thereof within ten (10) days of filing of the Notice of Completion.

9. WARRANTIES

The CONTRACTOR agrees to perform all work under this Contract in accordance with the CITY's designs, drawings and specifications.

The CONTRACTOR guarantees for a period of one (1) year from the date of the notice of completion of the work that the completed work is free from all defects due to faulty materials, equipment or workmanship and that he shall promptly make whatever adjustments or corrections which may be necessary to cure any defects, including repairs or any damage to other parts of the system resulting from such defects. The CITY shall promptly give notice to the CONTRACTOR of observed defects. In the event that the CONTRACTOR fails to make adjustments, repairs, corrections or other work made necessary by such defects, the CITY may do so and charge the CONTRACTOR the cost incurred. The performance bond shall remain in full force and effect through the guarantee period.

The CONTRACTOR'S obligations under this clause are in addition to the CONTRACTOR'S other express or implied assurances of this Contract or state law and in no way diminish any other rights that the CITY may have against the CONTRACTOR for faulty materials, equipment or work.

10. INDEPENDENT CONTRACTOR

It is understood and agreed that CONTRACTOR is, and shall be, acting at all times hereunder as an independent contractor and not an employee of CITY. CONTRACTOR shall secure at

its own cost and expense, and be responsible for any and all payment of all taxes, social security, state disability insurance compensation, unemployment compensation and other payroll deductions for CONTRACTOR and its officers, agents and employees and all business licenses, if any, in connection with the PROJECT and/or the services performed hereunder.

11. LIQUIDATED DAMAGES/DELAYS

It is agreed by the parties hereto that in case the total work called for hereunder is not in all parts and requirements finished or completed within the number of calendar days as set forth herein, damage will be sustained by CITY; and that it is, and would be, impractical and extremely difficult to ascertain and determine the actual damage which CITY would sustain in the event of and by reason of such delay. It is, therefore, agreed that CONTRACTOR will pay to CITY, as liquidated damages and not as a penalty, the sum of One Thousand Dollars (\$1,000.00) per each calendar days delay in completing the work in excess of the number of working/calendar days set forth herein, which represents a reasonable endeavor by the parties hereto to estimate a fair compensation for the foreseeable damages CITY would sustain in the event of and by reason of such delay; and CONTRACTOR agrees to pay these damages herein provided, and further agrees that CITY may deduct the amount thereof from any monies due or that may become due to CONTRACTOR hereunder.

CONTRACTOR will be granted an extension of time and will not be assessed damages for any portion of the delay in the completion of the work due to unforeseeable causes beyond the control and without the fault or negligence of CONTRACTOR, including, but not limited to, acts of God or of the public enemy, fire, floods, epidemics, quarantine restrictions, strikes, unsuitable weather, or delays of subcontractors due to such causes.

CONTRACTOR shall, within fifteen (15) days from the beginning of any such delay (unless DCS shall grant a further period of time), notify DCS in writing of the cause of the delay and CITY shall extend the time for completing the work if, in its judgment, the findings of fact thereon justify the delay; and the decision of DCS shall be conclusive on the parties hereto.

Should CONTRACTOR be delayed in the prosecution or completion of the work by the act, neglect or default of CITY, or should CONTRACTOR be delayed by waiting for materials required by this Agreement to be furnished by CITY, or by damage caused by fire or other casualty at the job site for which CONTRACTOR is not responsible, or by the combined action of the workers, in no way caused by or resulting from default or collusion on the part of CONTRACTOR, or in the event of a lockout by CITY, then the time herein fixed for the completion of the work shall be extended by the number of days CONTRACTOR has thus been delayed, but no allowance or extension shall be made unless a claim therefor is presented in writing to CITY within fifteen (15) days of the commencement of such delay.

No claims for additional compensation or damages for delays, irrespective of the cause thereof, and including without limitation the furnishing of materials by CITY or delays by other contractors or subcontractors, will be allowed and an extension of time for completion shall be the sole remedy of CONTRACTOR.

12. DEMANDS FOR ADDITIONAL TIME OR MONEY

A. Definitions.

(1) "Change Order" means a document signed by the CONTRACTOR and CITY which authorizes an addition, deletion or revision in the work, or an adjustment in the Compensation under Section 3, or the Completion Time specified at Section 4.

(2) "Demand" means a written demand for a Change Order by the CONTRACTOR for any of the following:

- (a) A time extension;

(b) Payment of money or damages arising from work done by, or on behalf of, the CONTRACTOR pursuant to this Agreement and payment of which is not expressly permitted pursuant to Section 3 of this Agreement;

(c) Payment of an amount the CITY disputes;

(d) Any disputes and other matters relating to the acceptability of the work performed or the interpretation of the Contract Documents;

(e) A request for a time extension or additional payment based upon differing site conditions, such as subsurface or latent physical conditions at the job site differing materially from those indicated in this Agreement or the Contract Documents, or unknown physical conditions at the job site, of an unusual nature, differing materially from those ordinarily encountered and generally recognized as inherent to work of the PROJECT; or

(f) A request for a time extension or additional payment based upon acts of neglect by CITY or due to fires, floods, labor disputes, epidemics, abnormal weather conditions or acts of God.

B. A Demand for a time extension or payment of money or damages may only be granted by a Change Order.

C. No Change Order may be granted except where the Contractor has submitted a Demand to the DCS (or his or her written designee). All Demands shall be submitted promptly, but in no event later than thirty (30) days after the occurrence of the event giving rise to the Demand. The Demand shall be in writing and include all documents necessary to substantiate the Demand. The DCS shall act on the Demand within fifteen (15) days after receipt, including by requesting additional information from the CONTRACTOR to determine whether to approve the Change Order the Demand seeks. The DCS shall act on the Demand within fifteen (15) days after receipt of the additional information or within a period of time no greater than the time the CONTRACTOR took to produce the additional information requested, whichever is greater.

D. Notwithstanding the thirty (30) days to submit a Demand under Subparagraph C, in the case of differing or unknown site conditions, immediately upon encountering the conditions, CONTRACTOR shall notify the DCS in writing of the conditions, so that the CITY may promptly investigate the conditions.

E. If the CONTRACTOR disputes the DCS's written response on the Demand, or the CITY fails to respond within the time prescribed, the CONTRACTOR may so notify the Community Services Director in writing, either within fifteen (15) days of receipt of the Community Services Director's response or within fifteen (15) days of the DCS's failure to respond within the time prescribed, respectively, and request an informal conference to meet and confer for settlement of the Demand. Upon the CONTRACTOR's request, the DCS shall schedule a meet and confer conference within thirty (30) days to seek to resolve.

F. CITY and CONTRACTOR shall execute appropriate Change Orders covering changes to the time or price by executing the Change Order by mutual agreement. If the CITY and CONTRACTOR are unable to reach a mutual agreement, then the City Project Manager shall issue a written decision on the claim within a reasonable time.

G. Following the meet and confer conference, if the Demand remains in dispute, the CONTRACTOR may file a claim with the City as provided in Chapter 1 (commencing with Section 900) and Chapter 2 (commencing with Section 910) of Part 3 of Division 3.6 of Title 1 of the Government Code. For purposes of those provisions, the running of the period of time within which a claim must be filed shall be tolled from the time the time the CONTRACTOR submits his or her Demand until the Demand is denied as a result of the meet and confer process, including any period of time utilized by the meet and confer process.

13. VARIATIONS IN ESTIMATED QUANTITIES

The quantities listed in the bid schedule will not govern final payment. Payment to CONTRACTOR will be made only for the actual quantities of Agreement items used in construction of the PROJECT, in accordance with the plans and specifications. Upon completion of the PROJECT, if the actual quantities used are either more than or less than the quantities listed in the bid schedule, the bid price shall prevail subject to the provisions of this Section. DCS may, at its sole discretion, when warranted by the facts and circumstances, order an equitable adjustment, upwards or downwards, in payment to CONTRACTOR where the actual quantities used in construction of the PROJECT are in variation to the quantities listed in the bid schedule. No claim by CONTRACTOR for an equitable adjustment in price or time for completion shall be allowed if asserted after final payment under this Agreement. If the quantity variation is such as to cause an increase in the time necessary for completion, DCS shall ascertain the facts and circumstances and make such adjustment for extending the completion date as in its sole judgment the findings warrant. .

14. PROGRESS PAYMENTS

Each month DCS will make an estimate in writing of the work performed by CONTRACTOR and the value thereof. From each progress estimate, five percent (5%) will be deducted and retained by CITY and the remainder of the progress estimate, less the amount of all previous payments since commencement of the work, will be paid to CONTRACTOR.

When CONTRACTOR has, in the judgment of DCS, faithfully executed fifty percent (50%) or more of the value of the work as determined from the bid schedule, and if DCS finds that satisfactory progress has been and is being made, CONTRACTOR may be paid such sum as will bring the payments of each month up to one hundred percent (100%) of the value of the work completed since the commencement of the PROJECT, as determined in its sole discretion by DCS, less all previous payments and less all previous retained amounts.

CITY's final payment to CONTRACTOR, if unencumbered, or any part thereof unencumbered, shall be made thirty (30) days after the acceptance of the work and the filing of a Notice of Completion by CITY. Provided, however, that in the event of a dispute between CITY and CONTRACTOR, CITY may withhold from the final payment an amount not to exceed 150 percent of the value of any disputed amount of work. Payments shall be made on demands drawn in the manner required by law, each payment to be accompanied by a certificate signed by DCS, affirming that the work for which payment is demanded has been performed in accordance with the terms of the Agreement and that the amount stated in the certificate is due under the terms of the Agreement. Partial payments on the contract price shall not be considered as an acceptance of any part of the work.

15. WITHHELD CONTRACT FUNDS SUBSTITUTION OF SECURITIES

At the request and at the sole cost and expense of CONTRACTOR, who shall retain beneficial ownership and receive interest, if any thereon, CITY shall permit the substitution and deposit therewith of securities equivalent to the amount of any monies withheld by CITY to ensure performance under the terms of this Agreement.

16. AFFIDAVITS OF SATISFACTION OF CLAIMS

After the completion of the work contemplated by this Agreement, CONTRACTOR shall file with DCS its affidavit stating that all workers and persons employed, all firms supplying materials and all subcontractors working upon the PROJECT have been paid in full and that there are no claims outstanding against the PROJECT for either labor or material, except certain items, if any, to be set forth in CONTRACTOR's affidavit covering disputed claims, or items in connection with Notices to Withhold, which have been filed under the provisions of the statutes of the State of California.

17. WAIVER OF CLAIMS

The acceptance by CONTRACTOR of the payment of the final certificate shall constitute a waiver of all claims against CITY under or arising out of this Agreement.

18. RISK AND INDEMNIFICATION

All work covered by this Contract done at the site of construction or in preparing or delivering materials to the site shall be at the risk of CONTRACTOR alone. CONTRACTOR agrees to save, indemnify and keep the CITY, its Officers, Agents, Employees, Engineers, and Consultants for this Contract, and all public agencies from whom permits will be obtained and their directors, Officers, Agents and Employees harmless against any and all liability, claims, judgments, costs and demands, including demands arising from injuries or death of persons (CONTRACTOR'S employees included) and damage to property, arising directly or indirectly out of the obligations herein undertaken or out of the operations conducted by CONTRACTOR, save and except claims or litigation arising through the active negligence or willful misconduct of CITY and will make good to reimburse CITY for any expenditures, including reasonable attorneys' fees CITY may incur by reason of such matters, and if requested by CITY, will defend any such suits at the sole cost and expense of CONTRACTOR.

19. INSURANCE

19.1 COMMENCEMENT OF WORK. CONTRACTOR shall not commence work under this Agreement until all certificates and endorsements have been received and approved by the CITY. All insurance required by this Agreement shall contain a statement of obligation on the part of the carrier to notify the city of any material change, cancellation, or termination at least **thirty (30) days** in advance. A **waiver of subrogation** shall be provided by the insurer for **each policy** waiving subrogation against CITY, its officers, officials, employees, agents, and volunteers for this contract and all public agencies from whom permits will be obtained and their directors, officers, agents, and employees, as determined by the CITY, **Claims made and modified occurrence policies shall not be accepted** for any policy. All Subcontractors shall be required to provide and maintain the same insurances as required of CONTRACTOR under this contract. CONTRACTOR shall be required to collect and maintain all required insurances from all Subcontractors.

19.2 CONTRACTOR is aware of the provisions of Section 3700 of the Labor Code, which requires every employer to be insured against liability for Workers' Compensation or undertake self-insurance in accordance with the provisions of that Code, and will comply with such provisions before commencing the performance of the work of this Contract.

19.3 CONTRACTOR and all Subcontractors shall carry workers' compensation insurance for the protection of its employees during the progress of the work. The insurer shall waive its rights of subrogation against the CITY, its officers, officials, employees, agents, and volunteers for this contract and all public agencies from whom permits will be obtained and their directors, officers, agents, and employees, as determined by the CITY, and shall issue a waiver of subrogation.

19.4 Before CONTRACTOR performs any work at, or prepares or delivers materials to, the site of construction, CONTRACTOR shall furnish:

Additional Insured Endorsements, **ongoing and products-completed operations**, for the **Commercial General Liability policy**, including mobile equipment and not excluding XCU. Endorsements shall designate CITY, its officers, officials, employees, agents, and

volunteers for this contract and all public agencies from whom permits will be obtained and their directors, officers, agents, and employees, as determined by the CITY, as additional insured's for liability arising out of work or operations performed by or on behalf of the CONTRACTOR. CONTRACTOR shall provide to CITY proof of insurance and endorsement forms (at least as broad as ISO Form CG 20 10, CG 11 85 or both CG 2010, CG 2026, CG 20 33, or CG 20 38; and CG 2037) that conform to CITY's requirements, as approved by the CITY. (Claims made and modified occurrence policies are not acceptable; Insurance companies must be acceptable to CITY and have a minimum A.M. Best Guide rating of A-, class VII or better, as approved by CITY).

An Additional Insured Endorsement for an **Automobile Liability** policy and shall designate CITY, its officers, officials, employees, agents, and volunteers for this contract and all public agencies from whom permits will be obtained and their directors, officers, agents, and employees, as determined by the CITY, as additional insured's for automobiles owned, leased, hired, or borrowed by the CONTRACTOR. CONTRACTOR shall provide to CITY proof of insurance, as approved by the CITY. (Claims made and modified occurrence policies are not acceptable; Insurance companies must be acceptable to CITY and have a minimum A.M. Best Guide rating of A-, class VII or better, as approved by CITY).

A Loss Payee Endorsement for the **Course of Construction** policy designating the City of Garden Grove as Loss Payee. (Claims made and modified occurrence policies are not acceptable; Insurance companies must be acceptable to CITY and have a minimum A.M. Best Guide rating of A-, class VII or better, as approved by CITY).

In the event any of CONTRACTOR'S underlying policies do not meet policy limits as required here in, CONTRACTOR shall provide the schedule of underlying policies for a **follows form excess liability** policy, state that the excess policy follows form on the insurance certificate, and an additional insured endorsement for the excess liability policy designating CITY, its officers, officials, employees, agents, and volunteers for this contract and all public agencies from whom permits will be obtained and their directors, officers, agents, and employees, as determined by the CITY, as additional insured's. (Claims made and modified occurrence policies are not acceptable; Insurance companies must be acceptable to CITY and have a minimum A.M. Best Guide rating of A-, class VII or better, as approved by CITY).

For any claims related to this Project, the CONTRACTOR's insurance coverage shall be primary insurance as respects CITY, its officers, officials, employees, agents, and volunteers for this contract and all public agencies from whom permits will be obtained and their directors, officers, agents, and employees, as determined by the CITY. Any insurance or self-insurance maintained by the CITY, its officers, officials, employees, agents, and volunteers for this contract and all public agencies from whom permits will be obtained and their directors, officers, agents, and employees, as determined by the CITY, shall be excess of the CONTRACTOR's insurance and not contribute with it.

19.5 Before CONTRACTOR performs any work at, or prepares or delivers materials to, the site of construction, CONTRACTOR shall furnish:

CONTRACTOR shall maintain all of the foregoing insurance coverage in force until the work under this Contract is fully completed. The requirement for carrying the foregoing insurance shall not derogate from the provisions for indemnification of CITY by CONTRACTOR under this Contract. Notwithstanding nor diminishing the obligations of CONTRACTOR with respect to the foregoing, CONTRACTOR shall subscribe for and maintain in full force and effect during the life of this Contract, the following insurance in amounts not less than the amounts specified and issued by a company admitted and licensed in California and having a Best's Guide Rating of A-Class VII or better (claims made and modified occurrence policies are not acceptable):

Workers' Compensation	As required by the State of California.
Employer's Liability	Not less than \$1,000,000 per accident for bodily injury or disease.
Commercial General Liability (including on-going operations, products - completed operations, and mobile equipment, and not excluding XCU)	Not less than \$5,000,000 per occurrence for bodily injury, personal injury and property damage.
Automobile Liability, for all automobiles including non-owned and hired vehicles	Not less than \$5,000,000 combined single limit for bodily injury and property damage.
Professional Liability	Not less than \$1,000,000 per occurrence for errors and omissions.
Bailee Coverage	Full value of playground equipment/ property in the care, custody, and control by CONTRACTOR.
Course of Construction	Completed value of the project with no coinsurance penalty provisions.
Follows Form Excess Liability	Required for any underlying policy that does not meet the underlying policy limits required herein.

If contractor maintains higher insurance limits than the minimums shown above, CONTRACTOR shall provide coverage for the higher limits otherwise maintained by the CONTRACTOR.

CITY or its representatives shall at all times have the right to inspect and receive a certified copy of all said policies of insurance, including certificates and endorsements at CONTRACTORS sole cost and expense. CONTRACTOR shall pay the premiums on the insurance hereinabove required.

20. CALIFORNIA PREVAILING WAGE LAW AND FEDERAL DAVIS-BACON ACT.

A. General Prevailing Rate. CITY has ascertained CONTRACTOR shall comply with all applicable requirements of Division 2, Part 7, Chapter 1 of the California Labor Code and all applicable federal requirements respecting the payment of prevailing wages. If there is a difference between the minimum wage rates predetermined by the Secretary of Labor and the prevailing wage rates determined by the Director of the Department of Industrial Relations (DIR) for similar classifications of labor, the CONTRACTOR and its Subcontractors shall pay not less than the higher wage rate. The DIR will not accept lower State wage rates not specifically included in the Federal minimum wage determinations. This includes "helper" (or other classifications based on hours of experience) or any other classification not appearing in the Federal Wage determinations. Where Federal wage determinations do not contain the State wage rate determination otherwise available for use by the CONTRACTOR and

Subcontractors, the CONTRACTOR and its Subcontractors shall pay not less than the Federal Minimum wage rate which most closely approximates the duties of the employees in question."

B. Forfeiture for Violation. CONTRACTOR shall, as a penalty to the CITY, forfeit one hundred dollars (\$100.00) for each calendar day or portion thereof for each worker paid (either by the CONTRACTOR or any subcontractor under it) less than the prevailing rate of per diem wages as set by the Director of Industrial Relations, in accordance with Sections 1770 1780 of the California Labor Code for the work provided for in this Contract, all in accordance with Section 1775 of the Labor Code of the State of California.

C. Apprentices. Section 1777.5, 1777.6 and 1777.7 of the Labor Code of the State of California, regarding the employment of apprentices is applicable to this Contract and the CONTRACTOR shall comply therewith; provided, however, that this requirement shall not apply if and/or to the extent that the Contract of the general CONTRACTOR, or the contracts of specialty contractors not bidding for work through a general or prime contractor involve less than thirty thousand dollars (\$30,000.00).

D. Workday. In the performance of this Contract, not more than eight (8) hours shall constitute a day's work, and CONTRACTOR shall not require more than eight (8) hours of labor in a day from any person employed by him hereunder except as provided in paragraph (5.14.2) above. CONTRACTOR shall conform to Article 3, Chapter 1, Part 7 (Sections 1810 et seq.) of the Labor Code of the State of California and shall forfeit to the CITY as a penalty, the sum of twenty five Dollars (\$25.00) for each worker employed in the execution of this Contract by CONTRACTOR or any subcontractor for each calendar day during which any worker is required or permitted to labor more than eight (8) hours in any one

E. Calendar day and forty (40) hours in any one week in violation of said Article. CONTRACTOR shall keep an accurate record showing the name and actual hours worked each calendar day and each calendar week by each worker employed by CONTRACTOR in connection with the Project.

F. Record of Wages: Inspection. CONTRACTOR agrees to maintain accurate payroll records showing the name, address, social security number, work classification, straight time and overtime hours worked each day and week, and the actual per diem wages paid to each journeyman, apprentice, worker or other employee employed by it in connection with the Project and agrees to require that each of its subcontractors does the same. The applicable CONTRACTOR or subcontractor or its agent having authority over such matters shall certify all payroll records as accurate. CONTRACTOR further agrees that its payroll records and those of its subcontractors shall be available to the employee or employee's representative, the Division of Labor Standards Enforcement, and the Division of Apprenticeship Standards and shall comply with all of the provisions of Labor Code Section 1776, in general. CONTRACTOR shall comply with all of the provisions of Labor Code Section 1776, and shall submit payroll records to the Labor Commissioner pursuant to Labor Code section 1771.4(a)(3). The CONTRACTOR shall submit copies of certified payroll reports and cancelled checks for laborers, every two weeks to the Project Manager. Certified payroll and cancelled checks submittals are due one month after start of construction and every two weeks thereafter. If the certified payroll and cancelled checks are not submitted, the CONTRACTOR will be notified that compliance is required within five (5) working days or contract work must cease. The CITY will not be responsible for any delay or acceleration charges or any incurred costs or damages as a result of the work stoppage due to CONTRACTOR's failure to comply. Work shall be ceased in an orderly, safe fashion with all vehicle access restored. Should this not occur, CITY will correct the deficiencies and deduct the cost from funds due to the CONTRACTOR. In addition, no progress payment shall be made until the copies of certified payroll reports and cancelled checks are submitted.

G. Contractor Registration. CONTRACTOR and its subcontractors must be registered with the California Department of Industrial Relations pursuant to Labor Code Section 1725.5. This Agreement shall not be effective until CONTRACTOR provides proof of registration to the CITY.

H. Posting of Job Site Notices. CONTRACTOR shall comply with the job site notices posting requirements established by the Labor Commissioner pursuant to Title 8, California Code of

Regulations Section 16461(e) or other regulation promulgated pursuant to Labor Code Section 1771.4(a) (2).

I. Notice of DIR Compliance Monitoring and Enforcement. Pursuant to Labor Code Section 1771.4, this Project is subject to compliance monitoring and enforcement by the California Department of Industrial Relations.

21. TERMINATION

This Contract may be terminated in whole or in part in writing by the CITY for its convenience, provided that the CONTRACTOR is given (1) not less than ten (10) calendar days written notice (delivered by certified mail, return receipt requested) of intent to terminate, and (2) an opportunity for consultation with the terminating party prior to termination.

If termination for default or convenience is effected by the CITY, an equitable adjustment in the price provided for in this Contract shall be made, but (1) no amount shall be allowed for anticipated profit on unperformed services or other work, and (2) any payment due to the CONTRACTOR at the time of termination may be adjusted to cover any additional costs to the CITY because of the CONTRACTOR'S default.

Upon receipt of a termination action, the CONTRACTOR shall (1) promptly discontinue all affected work (unless the notice directs otherwise), and (2) deliver or otherwise make available to the CITY all data, drawings, specifications, reports, estimates, summaries and such other information and materials as may have been accumulated by the CONTRACTOR in performing this Contract whether completed or in process.

Upon termination, the CITY may take over the work and may award another party an agreement to complete the work under this Contract.

22. DISPOSITION OF PLANS ESTIMATES AND OTHER DOCUMENTS

CONTRACTOR agrees that upon completion of the work to be performed hereunder, or upon expiration or earlier termination of this Agreement, all original plans, specifications, drawings, reports, calculations, maps and other documents pertaining to this Agreement shall be delivered to CITY and become its sole property at no further cost.

23. NONASSIGNABILITY

CONTRACTOR shall not sell, assign, transfer, convey or encumber this Agreement, or any part hereof, or any right or duty created herein, without the prior written consent of CITY and the surety.

24. CITY EMPLOYEES AND OFFICIALS

CONTRACTOR shall employ no CITY official nor any regular CITY employee in the work performed pursuant to this Agreement. No officer or employee of CITY shall have any financial interest in this Agreement in violation of the California Government Code.

25. STOP NOTICES- RECOVERY OF ADMINISTRATIVE COSTS

CITY shall be entitled to all reasonable administrative costs and necessary disbursements arising out of the processing of Stop Notices, Notices to Withhold, or any similar legal document. This obligation shall be provided for in the labor and materials payment bond required of CONTRACTOR. CITY may charge an administrative fee of One Hundred Dollars (\$100) for every Stop Notice filed in excess of two (2), regardless of whether or not CITY is named in an action to enforce such stop notices.

CITY may set off any unreimbursed cost or expense so incurred against any sum or sums owed by CITY to CONTRACTOR under this Agreement.

26. NOTICES

Any notices, certificates, or other communications hereunder shall be given either by personal delivery or by enclosing the same in a sealed envelope, postage prepaid, and depositing the same in the United States Postal Service, to the addresses specified below; provided that CITY and CONTRACTOR, by notice given hereunder, may designate different addresses to which subsequent notices, certificates or other communications will be sent:

TO CITY:

City of Garden Grove
ATTN: Janet Pelayo
11222 Acacia Parkway
Garden Grove, CA 92840
(714) 741-5200 Phone
(714) 741-5579 Fax

TO CONTRACTOR:

27. SECTION HEADINGS

The titles, captions, section, paragraph, and subject headings, and descriptive phrases at the beginning of the various sections in this Agreement are merely descriptive and are included solely for convenience of reference only and are not representative of matters included or excluded from such provisions, and do not interpret, define, limit or describe, or construe the intent of the parties or affect the construction or interpretation of any provision of this Agreement.

28. IMMIGRATION

CONTRACTOR shall be responsible for full compliance with the immigration and naturalization laws of the United States and shall, in particular, comply with the provisions of the Immigration Reform and Control Act of 1978 (8 USC Section 1324a) regarding employment verification.

29. ATTORNEY'S FEES

If any action at law or in equity is necessary to enforce or interpret the terms of this Contract, each shall bear its own attorneys' fees, costs and necessary disbursements. Notwithstanding the foregoing, if any action is brought against the CONTRACTOR or any subcontractor to enforce a Stop Notice or Notice to Withhold, which named the CITY as a party to said action, the CITY shall be entitled to reasonable attorneys' fees, costs and necessary disbursements arising out of the defense of such action by the CITY. The CITY shall be entitled to deduct its costs for any Stop Notice filed, whether court action is involved or not.

30. INTERPRETATION OF THIS AGREEMENT

The language of all parts of this Agreement shall in all cases be construed as a whole, according to its fair meaning, and not strictly for or against any of the parties. If any provision of this Agreement is held by an arbitrator or court of competent jurisdiction to be unenforceable, void, illegal or invalid, such holding shall not invalidate or affect the remaining covenants and provisions of this Agreement. No covenant or provision shall be deemed dependent upon any other unless so expressly provided here. As used in this Agreement, the masculine or neuter gender and singular or plural number shall be deemed to include the other whenever the context so indicates or requires. Nothing contained herein shall be construed so as to require the commission of any act contrary to law, and wherever there is any conflict between any provision contained herein and any present or future statute, law, ordinance or regulation contrary to which the parties have no right to contract, then the latter shall

prevail, and the provision of this Agreement which is hereby affected shall be curtailed and limited only to the extent necessary to bring it within the requirements of the law.

31. GOVERNING LAW

This Agreement shall be governed and construed in accordance with the laws of the State of California and venue shall be in Orange County.

32. DUPLICATE ORIGINAL

The original of this Agreement and one or more copies hereto have been prepared and signed in counterparts as duplicate originals, each of which so executed shall, irrespective of the date of its execution and delivery, be deemed an original. Each duplicate original shall be deemed an original instrument as against any party who has signed it.

33. CONSENT

Where CITYs consent/approval is required under this Agreement, its consent/approval for one transaction or event shall not be deemed to be consent/approval to any subsequent occurrence of the same or any other transaction or event.

34. CALIFORNIA FAIR EMPLOYMENT AND HOUSING ACT

CONTRACTOR agrees to comply with all requirements and utilize fair employment practices in accordance with California Government Code Sections 12900 et seq.

35. SIGNATORIES

Each undersigned represents and warrants that its signature herein below has the power, authority and right to bind their respective parties to each of the terms of this Agreement, and shall indemnify CITY fully for any injuries or damages to CITY in the event that such authority or power is not, in fact, held by the signatory or is withdrawn.

36. ENTIRETY

The foregoing set forth the entire Agreement between the parties. No waiver or modification of this Agreement shall be valid unless in writing duly executed by both parties.

The parties acknowledge and agree that they are entering into this Agreement freely and voluntarily following extensive arm's length negotiations, and that each has had the opportunity to consult with legal counsel prior to executing this Agreement. The parties also acknowledge and agree that no representations, inducements, promises, agreements or warranties, oral or otherwise, have been made by that party or anyone acting on that party's behalf, which are not embodied in this Agreement, and that that party has not executed this Agreement in reliance on any representation, inducement, promise, agreement, warranty, fact or circumstance not expressly set forth in this Agreement.

FAITHFUL PERFORMANCE BOND

Bond No. _____
Premium _____

NOTICE: TO WHOM IT MAY CONCERN: those we, _____,
_____,
as Principal, and _____,
as Surety, are held and firmly bound unto the City of Garden Grove, (CITY) in the sum of _____

_____ Lawful money of the United States, for the payment of which we bind heirs, our executors, administrators, successors, and ourselves jointly and severally.

That the Surety's office is located at _____,
telephone no. _____; the Surety is licensed to do business in the State of California; and the California Insurance Agent's License No., address, and telephone no. are as follows:

License No.: _____
Address: _____
Telephone No.: _____

That the following clause must be completed if, in fact, a non-resident agent for the Surety is a party to the transaction:

Name of non-resident agent: _____
Non-resident agent's office address: _____

Telephone No.: _____

THE CONDITION OF THIS OBLIGATION IS SUCH, that:

1. The Principal has agreed entered into a contract attached hereto, dated the _____ day of _____, 2022 with the CITY OF GARDEN GROVE for GARDEN GROVE PARK IMPROVEMENTS-PHASE 2, CITY PROJECT NO. 2163101280-2.
2. If the Principal shall well and truly perform, or cause to be performed, each and all of the requirements and obligations of the contract to be performed by the Principal, as set forth in the contract, then this bond shall be null and void; otherwise, it shall remain in full force and effect. In the event that suit is instituted to recover on this bond, the Surety will pay reasonable attorneys' fees.
3. Further, the Surety, for value received, hereby stipulates and agrees that no change, extension of time, alteration, or modification of the contract documents or of work performed shall in any way affect its obligation on this bond, and it does hereby waive notice of any change, extension of time, alteration, or modification of the contract documents, or of work to be performed.

FAITHFUL PERFORMANCE BOND (Continues)

Executed this ____ day of _____, 20__

Principal

Principal

By: _____
Surety

By: _____
Attorney-in-Fact

California Resident Agent

By: _____
Non-resident Agent - Attorney-in-Fact

STATE OF CALIFORNIA)
)
COUNTY OF _____) ss.

On this ____ day of _____, 20__, before me, a Notary Public in and for said County, residing therein, duly commissioned and sworn, personally appeared _____ known to me to be the Attorney-in-Fact of the _____, of _____ (Corporation), and acknowledged that it executed the attached bond to the _____ (State),

City of Garden Grove as such Attorney-in-Fact and as the free act and deed of the corporation, and that the bond was executed on behalf of the corporation by authority of its Board of Directors.

IN WITNESS WHEREOF, I have herewith set my hand and affixed my Official Seal, the day and year in this certificate first above written.

(Acknowledgment by Non-resident Agent as Attorney-in-Fact must be attached.)

Notary Public in and for said County and State
My Commission expires: _____

LABOR AND MATERIAL BOND

Bond No. _____
Premium _____

NOTICE: TO WHOM IT MAY CONCERN: those we, _____

_____ as Principal, and _____ as Surety, are held and firmly bound unto the City of Garden Grove, California ("CITY") in the sum of _____ Dollars (\$ _____), lawful money of the United States, for the payment of the sum, we bind heirs, our executors, administrators, successors, and ourselves jointly and severally.

That the Surety's office is located at _____, telephone no. _____; the Surety is licensed to do business in the State of California; and the California Insurance Agent's License No., address, and telephone no. are as follows:

License No.: _____
Address: _____
Telephone No.: _____

That the following clause must be completed if, in fact, a non-resident agent for the Surety is a party to the transaction:

Name of non-resident agent: _____
Non-resident agent's office address: _____

Telephone No.: _____

THE CONDITION OF THIS OBLIGATION IS SUCH, that:

1. The Principal has entered into a contract attached hereto, dated _____ day of _____, 2022, with the CITY OF GARDEN GROVE for **GARDEN GROVE PARK IMPROVEMENTS-PHASE 2, CITY PROJECT NO. 2163101280-2.**
2. If the Principal, its heirs, executors, administrators, successors, or assigns, or subcontractors, shall fail to pay for any materials, provisions, provender, or other supplies or teams, implements, or machinery used in, upon, for, or about, the performance of the improvement, or for any work or labor thereon of any kind, or for amounts due under the Unemployment Insurance Code with respect to work or labor, and provided that the claimant shall have complied with the provision of the code, the Surety or Sureties will pay for same in the amount not exceeding the sum specified in this bond; otherwise, the above obligation shall be void. In case suit is brought upon this bond, the Surety will pay reasonable attorneys' fees.
3. The Surety, for value received, hereby stipulates and agrees that no change, extension of time, alteration, or modification of the contract documents, or of work performed, shall in any way affect its obligation on this bond, and it does hereby waive notice of any change, extension of time, alteration, or modification of the contract documents, or of work to be performed.

LABOR AND MATERIAL BOND (Continues)

4. This bond shall inure to the benefit of any and all persons, companies, and corporations entitled to the claims under Civil Code 3181 et seq., so as to give a right of action to them or their assignees in any suit brought upon this bond.

Executed this ____ day of _____, 20____.

_____	_____
Principal	Principal
By: _____	_____
	Surety
By: _____	_____
	Attorney-in-Fact

	California Resident Agent
By: _____	_____
	Non-resident Agent - Attorney-in-Fact

STATE OF CALIFORNIA)
)
COUNTY OF _____) ss.

On this ____ day of _____, 20____, before me, a Notary Public in and for said County and State, personally appeared _____ known to me to be the Attorney-in-Fact of the _____, of _____ (Corporation) _____, and acknowledged that it executed the attached bond to the _____ (State) City of Garden Grove as such Attorney-in-Fact and as the free act and deed of the corporation, and that the bond was executed on behalf of the corporation by authority of its Board of Directors.

IN WITNESS WHEREOF, I have herewith set my hand and affixed my Official Seal, the day and year in this certificate first above written.

(Acknowledgment by Non-resident Agent as Attorney-in-Fact must be attached.)

Notary Public in and for said County and State
My Commission expires: _____

ESCROW AGREEMENT FOR SECURITY DEPOSITS IN LIEU OF RETENTION

This Escrow Agreement is made and entered into by and between
whose address is 1830 West 147th St. Gardena CA 90249
hereinafter called "owner",
whose address is _____
hereinafter called "contractor", Deane E & C Inc.
and _____, whose address
is _____
hereinafter called "escrow agent."

For the consideration hereinafter set forth, the owner, contractor, and escrow agent agree as follows:

(1) Pursuant to Section 22300 of the Public Contract Code of the State of California, the contractor has the option to deposit securities with the escrow agent as a substitute for retention earnings required to be withheld by the owner pursuant to the construction contract entered into between the owner and contractor for 365,640 in the amount of \$ dated April (hereafter referred to as the "contract"). Alternatively, on written request of the contractor, the owner shall make payments of the retention earnings directly to the escrow agent. When the contractor deposits the securities as a substitute for the contract earnings, the escrow agent shall notify the owner within ten days of the deposit. The market value of the securities at the time of the substitution shall be at least equal to the cash amount then required to be withheld as retention under the terms of the contract between the owner and contractor. Securities shall be held in the name of the _____ and shall designate the contractor as the beneficial owner.

(2) The owner shall make progress payments to the contractor for those funds which otherwise would be withheld from progress payments pursuant to the contract provision, provided that the escrow agent holds securities in the form and amount specified above.

(3) When the owner makes payment of retentions earned directly to the escrow agent, the escrow agent shall hold them for the benefit of the contractor until such time as the escrow created under this contract is terminated. The contractor may direct the investment of the payments into securities. All terms and conditions of this agreement and the rights and responsibilities of the parties shall be equally applicable and binding when the owner pays the escrow agent directly.

(4) The contractor shall be responsible for paying all fees for the expenses incurred by the escrow agent in administering the escrow account. These expenses and payment terms shall be determined by the contractor and escrow agent.

(5) The interest earned on the securities or the money market accounts held in escrow and all interest on the interest shall be the sole account of contractor and shall be subject to withdrawal by contractor at any time and from time to time without notice to the owner.

(6) The contractor shall have the right to withdraw all or any part of the principal in the escrow account only by written notice to the escrow agent accompanied by written authorization from the owner to the escrow agent that the owner consents to the withdrawal of the amount sought to be withdrawn by contractor.

(7) The owner shall have a right to draw upon the securities in the event of default by the contractor. Upon two days' written notice to the escrow agent from the owner of the default, the escrow

agent shall immediately convert the securities to cash and shall distribute the cash as instructed by the owner.

(8) Upon receipt of written notification from the owner certifying that the contract is final and complete, and that the contractor has complied with all requirements and procedures applicable to the contract, the escrow agent shall release to the contractor all securities and interest on deposit less escrow fees and charges of the escrow account. The escrow shall be closed immediately upon disbursement of all moneys and securities on deposit and payment of fees and charges.

(9) The escrow agent shall rely on the written notifications from the owner and the contractor pursuant to Sections (1) to (8), inclusive, of this agreement and the owner and contractor shall hold the escrow agent harmless from the escrow agent's release, conversion, and disbursement of the securities and interest as set forth above.

(10) The names of the persons who are authorized to give written notice or to receive written notice on behalf of the owner and on behalf of the contractor in connection with the foregoing, and exemplars of their respective signatures are as follows:

On behalf of the owner:

On behalf of the contractor:

On behalf of the owner:
Title

On behalf of the contractor:
Title

Name

Name

Signature

Signature

Address

Address

Deark E & O Inc.

Project Manager

Beak Jeong



1830 W. 147th St,
Gardena, CA 90249.

On behalf of the escrow agent:
Title

Title

Name

Name

Signature

Signature

Address

Address

At the time the escrow account is opened, the owner and contractor shall deliver to the escrow agent a fully executed counterpart of this Agreement.

IN WITNESS WHEREOF, the parties have executed this Agreement by their proper officers on the date first set forth above.

Owner/Contractor _____

Dated: _____

Title/Title _____

Approved as to Form _____

City Attorney

ADDENDUM No. 1

Covering

CHANGE IN SPECIFICATIONS AND/OR PLANS

Date Issued: March 21, 2022

Date Effective: March 21, 2022

IFB No. City Project 2163101280-2 Garden Grove Park Improvements-Phase Two Project

INTENT

1. This addendum is issued prior to receipt of bids to provide for modifications in plans and/or specifications. Acknowledgment of this addendum shall be made and cost for work included in proposer's submittal.
2. The following questions were asked regarding the project named above. The City's responses can be found in the bold and italicized font.
 1. Is there an Engineer's Estimated Value for the project? ***An Engineer's Estimated Value cost for this project is not available.***
 2. Is the project subject to a PLA (Project Labor Agreement), a PSA (Project Stabilization Agreement), a CBA (Collective Bargaining Agreement), a CWA (Community Workforce Agreement), or anything of that nature? ***This project is not subject to these type of agreements.***
3. What is the process for submitting "alternatives" or "proposed equals" for the City's review? ***The Bidder shall note in his submittal any and all "alternatives" or "proposed equals" that it proposes to use in lieu of any named or designated material, product or thing that is named in the specifications and followed by the words "or equal." In the event there are "alternatives" or "proposed equals", the bidder shall specifically itemize them in his bid under a heading entitled "Proposed Equals". Failure to do so shall render the bidder's bid non-responsive. In addition, if any "alternatives" or "proposed equals" are proposed by the bidder, the bidder must submit a request for substitution of proposed equal to the City within ten (10) working days of the bid closing date. This request shall include any and all appropriate data substantiating that the proposed item is "equal" to the item listed in the specifications. Failure to submit said request within the required timeframe shall cause for its immediate rejection by the City. The City shall review the bidder's submission and shall render a decision no later than five (5) business days before the bid closing date. The bidder shall be notified in writing of the City's decision. The City reserves***

the right to reject any and all bids that do not meet the bid requirements and/or those bids submitted with "alternatives" or "proposed equals" that have not been previously approved by the City. The final decision as to whether or not any "alternatives" or "proposed equals" will be accepted shall be at the the City's sole discretion. All requests for substitution or proposed equals shall be submitted via email to janetp@ggcity.org.

The contractor is hereby notified that Addendum 1 must be acknowledged and submitted as part of the bid. Failure to do so, could result in the City designating said bid as "Non Responsive". All other terms and conditions of the BID shall remain the same.

Issued by: Sandra Segawa
Sandra Segawa, C.P.M., CPPB
Purchasing Division Manager
City of Garden Grove

Mark E & C

A handwritten signature in black ink, appearing to be 'Mark E & C'.

4/8/22

ADDENDUM No. 2

Covering

CHANGE IN SPECIFICATIONS AND/OR PLANS

Date Issued: March 24, 2022

Date Effective: March 24, 2022

IFB No. City Project 2163101280-2 Garden Grove Park Improvements-Phase
Two Project

INTENT

1. This addendum is issued prior to receipt of bids to provide for modifications in plans and/or specifications. Acknowledgment of this addendum shall be made and cost for work included in proposer's submittal.
2. The following questions were asked regarding the project named above.

Q: How many light poles and benches are part of the project?

A: 4 benches and 4 light pole fixtures

Q: Do you have the engineer estimated cost?

A: The City does not have an estimated cost. This question was already answered in Addendum No. 1. All bidders are responsible for checking the City's Planet Bids portal for addenda that are posted.

Q: What is the anticipated award and start date?

A: Bids will be opened on April 11, 2022 and will go through the lowest/responsible bidder process. It is anticipated that the City will award the contract and have the contractor on board by early May, 2022. The City is expecting to receive playground equipment in May, 2022.

Q: Where are the bids to be submitted?

A: This information is in the bid package, bidders can either mail or drop off in person at the Annex Building adjacent to City Hall. If bids are hand deliver, a confirmation receipt can be issued.

Q: Is Planet Bids also an option for submitting bids?

A: No. Registration would need to go through Planet Bids but the bid package itself must be mailed or dropped off in person to the address noted in the bid document.

Q: If already registered on Planet Bids as a plan holder, does one get automatic notifications for things such as addendums?

A: All bidders who are registered on the City's PlanetBids portal will receive emails when an addendum has been posted. Please make sure that these emails are not going to a spam file. The City is not responsible for emails that go to spam files. Once registered on the City's Planet Bids portal, bidders

must log into the bid and open the bid document to be moved into "Prospective Bidder" status. If these steps are not followed, information will be not be emailed. Please keep in mind that it is the responsibility of all bidders to check the City's PlanetBids portal for addenda and all updates.

Q: I have not seen any addendums.

A: Please see the response to the previous question.

Q: Is shade canopy part of the project?

A: Yes, it is part of the playground equipment.

Q: What was on the addendum?

A: A couple of items were answered: 1) Engineer's estimated cost; 2) Identified process if company wants to be considered an equal for playground surface; and 3) If there were other type of agreements that are part of this project. Please email any additional questions to janetp@ggcity.org by the specified deadline.

Q: Can you provide a list of contractors that attended this mandatory job walk?

A: The mandatory sign in sheet has been posted on the City's PlanetBids portal for this bid. The document can be found under the "Documents" tab.

3. The following items apply to the Scope of Work and must be taken into consideration by all bidders:

Project Manager informed proposed bidders that the selected contractor will be working with the playground company for any specific questions regarding installation of the units. Irrigation work will be handled in-house by City staff. The old playground equipment will be removed by City staff.

Proposed bidders should include cost for the storage of the playground equipment, under line item Storing & Installing Playground. Additionally, the selected Contractor will be responsible to receive, verify and store the playground equipment prior to installation. The storage can be done at the project site in an approved location by the City, but any container units used will be an expense covered by the Contractor. Contractor will be responsible to secure all equipment and work completed at job site, especially when the playground surface is poured.

The contractor is hereby notified that Addenda 1 and 2 must be acknowledged and submitted as part of the bid. Failure to do so, could result in the City designating said bid as "Non Responsive". All other terms and conditions of the BID shall remain the same.

Issued by: *Sandra Segawa*
Sandra Segawa, C.P.M., CPPB
Purchasing Division Manager
City of Garden Grove

Deavk E S Q
[Signature] 4/10/22

+13462487799, 83250572655# US (Houston)

Dial by your location

- +1 669 900 6833 US (San Jose)
- +1 346 248 7799 US (Houston)
- +1 253 215 8782 US (Tacoma)
- +1 301 715 8592 US (Washington DC)
- +1 312 626 6799 US (Chicago)
- +1 929 205 6099 US (New York)

Meeting ID: 832 5057 2655

Find your local number: <https://ggcity-org.zoom.us/j/83250572655>

Join by SIP

83250572655@zoomcrc.com

Join by H.323

- 162.255.37.11 (US West)
 - 162.255.36.11 (US East)
 - 115.114.131.7 (India Mumbai)
 - 115.114.115.7 (India Hyderabad)
 - 213.19.144.110 (Amsterdam Netherlands)
 - 213.244.140.110 (Germany)
 - 103.122.166.55 (Australia Sydney)
 - 103.122.167.55 (Australia Melbourne)
 - 149.137.40.110 (Singapore)
 - 64.211.144.160 (Brazil)
 - 149.137.68.253 (Mexico)
 - 69.174.57.160 (Canada Toronto)
 - 65.39.152.160 (Canada Vancouver)
 - 207.226.132.110 (Japan Tokyo)
 - 149.137.24.110 (Japan Osaka)
- Meeting ID: 832 5057 2655
Passcode: 862327

The contractor is hereby notified that Addenda 1, 2 and 3 must be acknowledged and submitted as part of the bid. Failure to do so, could result in the City designating said bid as "Non Responsive". All other terms and conditions of the BID shall remain the same.

Issued by: *Sandra Segawa*
Sandra Segawa, C.P.M., CPPB
Purchasing Division Manager
City of Garden Grove

Dark E SO

[Signature]

4/8/22

ADDENDUM No. 3

Covering

CHANGE IN SPECIFICATIONS AND/OR PLANS

Date Issued: March 31, 2022

Date Effective: March 31, 2022

IFB No. City Project 2163101280-2 Garden Grove Park Improvements – Phase 2

INTENT

1. This addendum is issued prior to receipt of bids to provide for modifications in plans and/or specifications. Acknowledgment of this addendum shall be made and cost for work included in proposer's submittal.
2. The following questions were asked regarding the project and the questions and answers are as follows:

Question#1:

Keynote 8 on sheet L-1 is calling out "Catch Basin Under Surfacing". However on the layout, there was no Keynote 8 indicated. We need the location/s and quantity of these catch basins. Also, there is no bid item allocated for these catch basin unless you want this cost included on bid item 7 - Resilient Play Surfacing. Please clarify.

CONSTRUCTION LEGEND

- 1 4" THICK CONCRETE PAVING
FINISH: MEDIUM BROOM
COLOR: NATURAL GRAY
REFER TO DETAIL '1', SHEET L-2
- 2 RUBBER SURFACING
REFER TO DETAIL '5', SHEET L-2
NOTE: WEAR COURSE TO BE 100% COLOR.
- 3 PATHWAY LIGHTS - REFER TO ELECTRICAL SHEETS
- 4 ANGLED BENCH W/ BACK MODEL #424
COLOR: TIERRA
TEXTURE: SMOOTH
AVAILABLE FROM OUTDOOR CREATIONS,
(530) 338-8367 OR AN APPROVED EQUAL
REFER TO DETAIL '1', SHEET L-3
- 5 CONCRETE PLAY AREA CURB
REFER TO DETAIL '7', SHEET L-2
- 6 2-5 YEAR PLAYGROUND
PLAY EQUIPMENT TO BE SELECTED BY
CONTRACTOR PER SPECIFICATIONS
- 7 5-12 YEAR PLAYGROUND
PLAY EQUIPMENT TO BE SELECTED BY
CONTRACTOR PER SPECIFICATIONS
- 8 CATCH BASIN UNDER SURFACING
REFER TO DETAIL '6', SHEET L-2
- 9 PIP SURFACING LANDING PATTERN -
REFER TO DETAIL '2', SHEET L-3

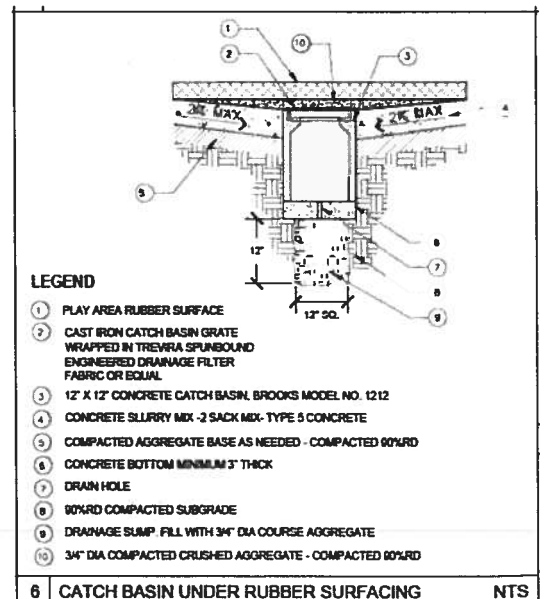

Answer#1:

There is to be one Catch Basin for each playground sub-area (generally centered within each space); so a total of two catch basins. The costs for the development of the catch basins is to be inclusive in the bid amount for Bid Item #7: Resilient Play Surfacing & Slurry Base.

Question#2:

Please provide the actual color blend(s) for the playground safety surfacing Design - L-1 just states 100% Color.

Answer#2:

Play Surfacing colors shall be standard colors, to include:

White/Crème/Eggshell
Light Grey
Standard Green

Note: The following surfacing manufacturers have been approved as an Equal for this project:

Spectra Turf;

No Fault Safety Surfacing (NFSS);

Tot Turf by Robertson Recreational Surfaces;

Gotham Poured Rubber

3. Per Page 6 of the bid document, **the bid opening will be teleconferenced; teleconferencing information will be made available at least 7 days ahead of the bid opening date.**

The following is the teleconferencing information for the bid opening that will take place at **11:00 AM, local time, on Monday, April 11, 2022.**

Topic: Garden Grove Park Improvements-Phase 2 City Project No. 2163101280-2
Time: Apr 11, 2022 11:00 AM Pacific Time (US and Canada)

Join Zoom Meeting

<https://ggcity-org.zoom.us/j/83250572655?pwd=Z2JaMldOSG8rVksrL2dMVXR2dTlqUT09>

Meeting ID: 832 5057 2655

Passcode: 862327

One tap mobile

+16699006833, 83250572655# US (San Jose)

ADDENDUM No. 4

Covering

CHANGE IN SPECIFICATIONS AND/OR PLANS

Date Issued: April 5, 2022

Date Effective: April 5, 2022

IFB No. City Project 2163101280-2 Garden Grove Park Improvements -
Phase 2

INTENT

1. This addendum is issued prior to receipt of bids to provide for modifications in plans and/or specifications. Acknowledgment of this addendum shall be made and cost for work included in proposer's submittal.
2. The following question was asked regarding the project and the question and answer is as follows:

Question: What is the fall height for 2-5 playground structure and fall Height for 5-12 playground structure? Innovative Playgrounds Company, the playground manufacturer, has provided the following response for this question:

The CFH for the 5-12 year old playground area is 12 feet and the CFH for the 2-5 playground area is 6 feet.

The contractor is hereby notified that Addenda 1, 2, 3 and 4 must be acknowledged and submitted as part of the bid. Failure to do so, could result in the City designating said bid as "Non Responsive". All other terms and conditions of the BID shall remain the same.

Issued by: *Sandra Segawa*
Sandra Segawa, C.P.M., CPPB
Purchasing Division Manager
City of Garden Grove

Derek E. S. Q.

[Signature]

4/8/22

GC.

▼ Contractor's License Detail for License # 1059536

DISCLAIMER: A license status check provides information taken from the CSLB license database. Before relying on this information, you should be aware of the following limitations.

- ▶ CSLB complaint disclosure is restricted by law (B&P 7124.6) If this entity is subject to public complaint disclosure click on link that will appear below for more information. Click here for a definition of disclosable actions.
- ▶ Only construction related civil judgments reported to CSLB are disclosed (B&P 7371.17)
- ▶ Arbitrations are not listed unless the contractor fails to comply with the terms.
- ▶ Due to workload, there may be relevant information that has not yet been entered into the board's license database.

Data current as of 4/11/2022 9:47:59 AM

Business Information

DEARK E&C INC
1830 W 147TH STREET
GARDENA, CA 90249
Business Phone Number:(424) 344-2380

Entity Corporation
Issue Date 10/23/2019
Expire Date 10/31/2023

License Status

This license is current and active.
All information below should be reviewed.

Classifications

- ▶ B - GENERAL BUILDING
- ▶ A - GENERAL ENGINEERING

Bonding Information

Contractor's Bond

This license filed a Contractor's Bond with HUDSON INSURANCE COMPANY.
Bond Number: 30050133
Bond Amount: \$15,000
Effective Date: 09/18/2021
Contractor's Bond History

Bond of Qualifying Individual

The qualifying individual DONG KEUN JIN certified that he/she owns 10 percent or more of the voting stock/membership interest of this company; therefore, the Bond of Qualifying Individual is not required.
Effective Date: 08/06/2020
BQI's Bond History

Workers' Compensation

This license has workers compensation insurance with the EVEREST PREMIER INSURANCE COMPANY
Policy Number: 7600022621211
Effective Date: 08/18/2021
Expire Date: 08/18/2022
Workers' Compensation History

State of California

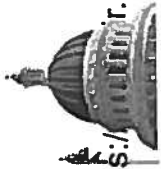

(<https://www.dir.ca.gov/>)

Department of Industrial Relations

Contractor Information		Registration History	
Legal Entity Name	DEARK E&C, INC	Effective Date	06/30/21
Legal Entity Type	Corporation	Expiration Date	06/30/22
Status	Active		
Registration Number	PW-LR-1000579126		
Registration effective date	07/01/21		
Registration expiration date	06/30/22		
Mailing Address	1830 W. 147TH ST GARDENA 90249 CA United States ...		
Physical Address	1830 W. 147TH ST GARDENA 90249 CA United States ...		
Email Address	slee@dearcec.com		
Trade Name/DBA			
License Number (s)	CSLB:1059536		
	CSLB:1059536		
	Back to DIR>> (https://www.dir.ca.gov/)		

AC

Legal Entity Information	
Corporation Entity Number:	4192754
Federal Employment Identification Number:	831987278
President Name:	DONG KEUN JIN
Vice President Name:	

Sub.

▼ Contractor's License Detail for License # 854429

DISCLAIMER: A license status check provides information taken from the CSLB license database. Before relying on this information, you should be aware of the following limitations.

- ▶ CSLB complaint disclosure is restricted by law (B&P 7124.6) If this entity is subject to public complaint disclosure click on link that will appear below for more information. [Click here for a definition of disclosable actions.](#)
- ▶ Only construction related civil judgments reported to CSLB are disclosed (B&P 7071.17).
- ▶ Arbitrations are not listed unless the contractor fails to comply with the terms.
- ▶ Due to workload, there may be relevant information that has not yet been entered into the board's license database.

Data current as of 4/11/2022 9:57:17 AM

Business Information

SPECTRASYSTEMS INC
dba SPECTRATURF

555 S PROMENDE AVE #103
CORONA, CA 92879
Business Phone Number:(951) 736-3579

Entity Corporation
Issue Date 02/11/2005
Expire Date 02/28/2023

License Status

This license is current and active.
All information below should be reviewed.

Classifications

- ▶ C-61 / D12 - SYNTHETIC PRODUCTS
- ▶ C-61 / D34 - PREFABRICATED EQUIPMENT

Bonding Information

Contractor's Bond

This license filed a Contractor's Bond with BERKLEY INSURANCE COMPANY.
Bond Number: 0167561
Bond Amount: \$15,000
Effective Date: 01/01/2016
[Contractor's Bond History](#)

Bond of Qualifying Individual

This license filed Bond of Qualifying Individual number **0207082** for MARK BROWN HOLLOWELL in the amount of **\$12,500** with BERKLEY INSURANCE COMPANY.
Effective Date: 03/15/2017

Workers Compensation

This license has workers compensation insurance with the AMERICAN ZURICH INSURANCE COMPANY
Policy Number: WC651064625
Effective Date: 04/01/2021
Expire Date: 04/01/2023
[Workers' Compensation History](#)

Other

- ▶ Personnel listed on this license (current or disassociated) are listed on other licenses.

Sub



State of California

Department of Industrial Rel

(<https://www.dir.ca.gov/>)

Contractor Information

Legal Entity Name

SPECTRASYSTEMS, INC

Legal Entity Type

Corporation

Status

Active

Registration Number

1000002615

Registration effective date

07/01/21

Registration expiration date

06/30/22

Mailing Address

555 S. PROMENADE AVE #103 CORONA 92879 CA ...

Physical Address

555 S. PROMENADE AVE #103 CORONA 92879 CA ...

Email Address

ccrockett@spectraturf.com

Trade Name/DBA

SPECTRATURF

License Number (s)

CSLB:854429

CSLB:854429

Back to DIR>> (<https://www.dir.ca.gov/>)

Registration History

Effective Date	Expiration Date
05/02/18	06/30/19
05/02/17	06/30/18
05/06/16	06/30/17
06/10/15	06/30/16
11/10/14	06/30/15
07/01/19	06/30/20
07/01/20	06/30/21
07/01/21	06/30/22

Legal Entity Information

Corporation Entity Number:

235-7424-7

Federal Employment Identification Number:

President Name:

ARTHUR DODGE

Vice President Name:

Treasurer Name:

Secretary Name:

ELIZABETH ANDERSON

CEO Name:

ARTHUR DODGE

Agency for Service:

Agent of Service Name:

CT CORPORATION

Agent of Service Mailing Address:

818 WEST SEVENTH ST LOS ANGELES 9

Sub

▼ Contractor's License Detail for License # 857288

DISCLAIMER: A license status check provides information taken from the CSLB license database. Before relying on this information, you should be aware of the following limitations.

- ▶ CSLB complaint disclosure is restricted by law (B&P 7124.6) If this entity is subject to public complaint disclosure click on link that will appear below for more information. Click here for a definition of disclosable actions.
- ▶ Only construction related civil judgments reported to CSLB are disclosed (B&P 7071.17).
- ▶ Arbitrations are not listed unless the contractor fails to comply with the terms.
- ▶ Due to workload, there may be relevant information that has not yet been entered into the board's license database.

Data current as of 4/11/2022 10:04:06 AM

Business Information

VELECTRIC TECHNOLOGIES
12407 BALTIMORE AVE
MORENO VALLEY, CA 92557
Business Phone Number:(951) 538-8414

Entity Sole Ownership
Issue Date 04/13/2005
Expire Date 04/30/2023

License Status

This license is current and active.

All information below should be reviewed.

Classifications

C10 - ELECTRICAL

Bonding Information

Contractor's Bond

This license filed a Contractor's Bond with HUDSON INSURANCE COMPANY.

Bond Number: 30035166

Bond Amount: \$15,000

Effective Date: 04/26/2019

[Contractor's Bond History](#)

Workers' Compensation

This license is exempt from having workers compensation insurance; they certified that they have no employees at this time.

Effective Date: 04/12/2021

Expire Date: None

[Workers' Compensation History](#)

Sub



State of California
Department of Industrial Rel

Contractor Information

Registration History

Legal Entity Name

Velectric Technologies

Legal Entity Type

Sole Proprietorship

Status

Active

[Back to DIR>> \(https://www.dir.ca.gov/\)](https://www.dir.ca.gov/)

Registration Number

PW-LR-1000872040

Registration effective date

03/01/22

Registration expiration date

06/30/22

Mailing Address

12407 Baltimore Ave Moreno Valley 92557 CA Unit...

Physical Address

12407 Baltimore Ave Moreno Valley 92557 CA Unit...

Email Address

spark@dearkec.com

Trade Name/DBA

License Number (s)

CSLB:857288

Effective Date

03/01/22

Expiration Date

06/30/22

Legal Entity Information

Federal Employment Identification Number:

Sole Proprietor Name:

Fernando Velez

Worker's Compensation

Do you lease employees through Professional Employer Organization (PEO)?:

No

Please provide your current worker's compensation insurance information below:

PEO InformationName	PEO Phone	PEO Email

Exempt from workers' compensation insurance

Exempt Reason:

Owner/O

Insurance Carrier: