

CITY OF GARDEN GROVE

PLOT PLAN

DEVELOPMENT SERVICES DEPARTMENT



OWNER THE WHERE HOUSE	JOB ADDRESS 13916 Brookhurst Ave	PERMIT NO. 147603A
NAME OF CONSTRUCTION LENDER & BRANCH	ASSASSORS PARCEL NO. 09934409	LOT BLOCK TRACT
	PLEASE CHECK ONE OR MORE <input checked="" type="checkbox"/> New <input type="checkbox"/> Addition <input type="checkbox"/> Alteration <input type="checkbox"/> Repair <input type="checkbox"/> Move <input type="checkbox"/> Demolish	
ADDRESS	DATE 9/3/86	PERMIT VALUE 25,000
CITY	JOB DESCRIPTION (2) POLE SIGNS	

SHOW NORTH ARROW, PROPERTY LINES AND ADJACENT STREETS.

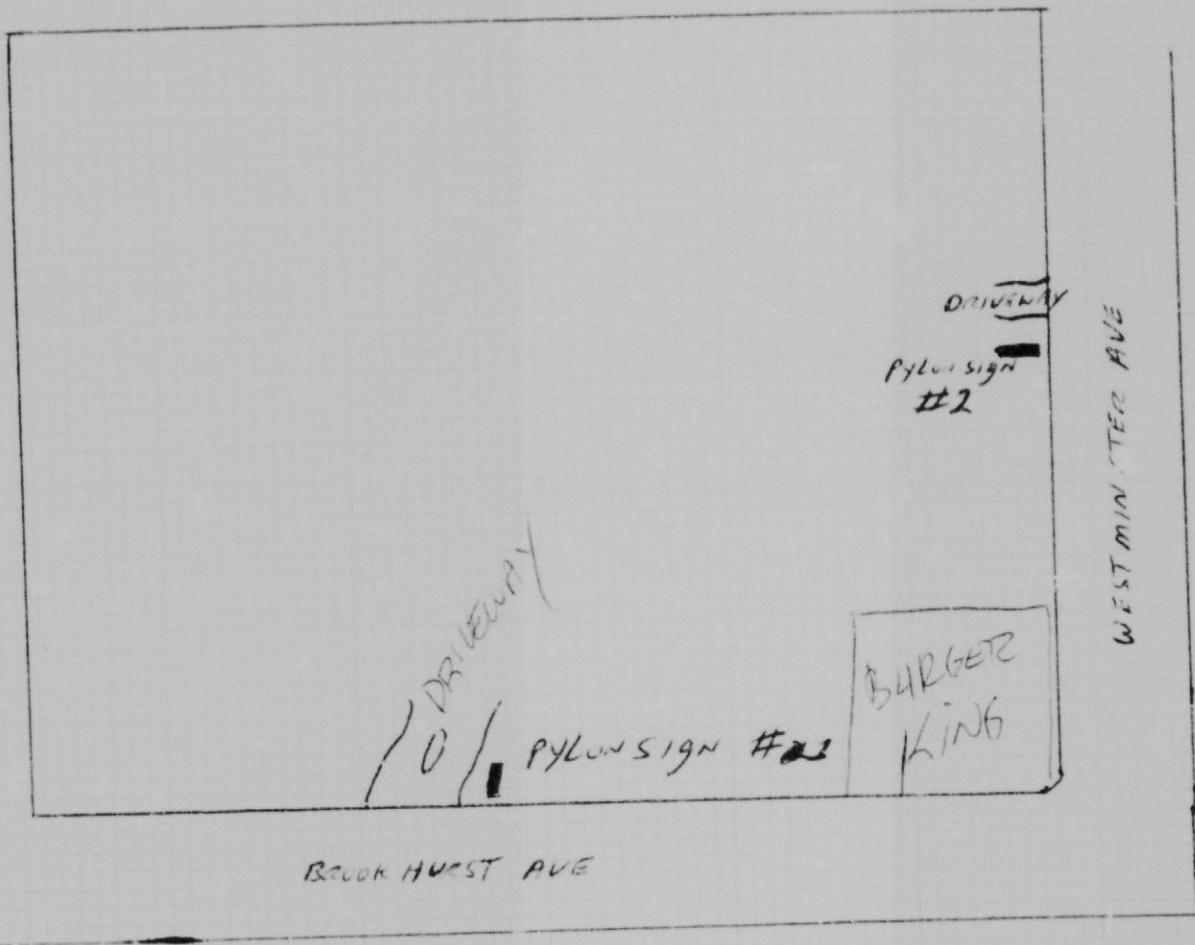

PLOT PLAN APPROVED BY _____

#1 Building Insp./#2 Assessor/#3 Permittee/#4 File
I certify the information on this form is complete and correct.

By _____

CITY OF GARDEN GROVE
SIGN FIELD CHECK

PERMIT # _____

DATE: 8/29/86

RECEIVED BY: Loepp

ASSIGNED TO: _____

BY: _____

DATE: 1 / 1

ADDRESS: 13916 BROOK HURST
PERSON TO CONTACT: ~~Jim Wright~~ ^{overseer} PHONE: (213) 927 4701
CONTRACTOR: LUMINOUS NEON LIGHTING
OWNER: ~~THE GARDEN GROVE PLAZA~~

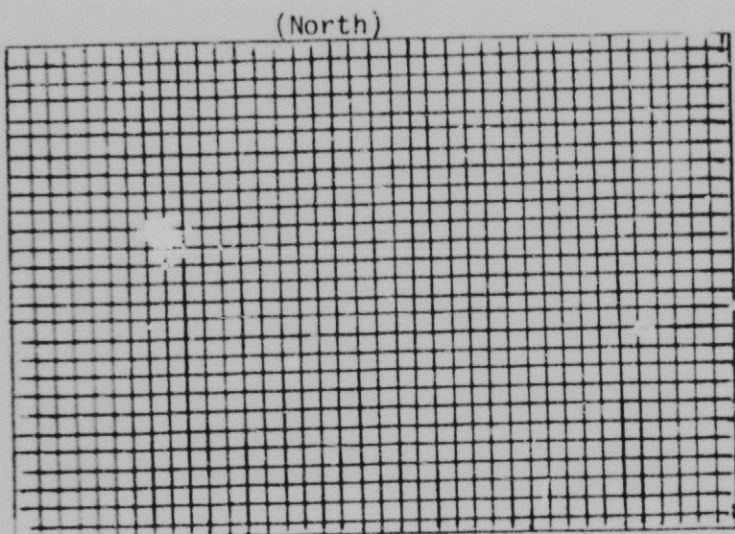

ZONE C-2 PRIMARY SECONDARY
BUILDING FRONTAGE _____
LOT FRONTAGE _____
ALLOWABLE AREA _____

COMMENTS:	EXISTING		PROPOSED	
	TYPE	AREA	TYPE	AREA
() OWNERS APPROVAL REQUIRED FOR POLE SIGN	1	_____	7	<u>Pylon (2) 360 sq ea.</u>
() SIGNS # (), (), () ERECTED PRIOR TO ISSUANCE OF PERMIT	2	_____	8	_____
() MATERIAL OF SIGNS # (), (), DO NOT MEET CODE.	3	_____	9	_____
() OTHER <u>There is no</u>	4	_____	10	_____
<u>specifications for size</u>	5	_____	11	_____
<u>allowable - Approved by</u>	6	_____	12	_____
<u>The Garden Grove City Council</u>	TOTAL	_____	TOTAL	<u>720 sq</u>
<u>Blanning Com. - denied</u>	COMBINED TOTAL	_____		<u>(720 sq)</u>
<u>per J. Silver</u>	(OVER) (UNDER)	_____		
	(APPROVED) (DENIED) BY:	_____		<u>Jim Dexter</u>



**CITY OF GARDEN GROVE
BUILDING SERVICES**

**13916 BROOKHURST
ST**

**PERMIT#:16-2587
ISSUED:8/30/16**

**General Info : 714-741-5307
Inspection Requests : 855-380-8758**

Owner CHOE, WINSTON TRUST			Telephone	Zip 92843	Building Address 13916 BROOKHURST ST																																				
Address 13916 BROOKHURST ST		City Garden Grove	State CA	Suite/Unit/Building SUITE A																																					
Applicant DUNG LE			Telephone 714-981-4098	Zip 92843	TYPE Alterations																																				
Address 10718 WESTMINSTER ST, #A		City WESTMINSTER	State CA	ISSUED BY Isabella Zandvliet																																					
State Licence 1016713		Expires N/A	City Licence	Expires	Inspector Dist N16	Parcel Number 09934413	LOT TRACT																																		
Contractor DUNG LE			Telephone 714-981-4098	Zip 92843	Valuation \$6,500.00																																				
Address 10718 WESTMINSTER ST, #A		City WESTMINSTER	State CA	Final Inspector's Signature <u>[Signature]</u> Date <u>11.29.16</u>																																					
State Licence 1016713		Expires N/A	City Licence	Expires	<table border="1" style="width:100%; border-collapse: collapse;"> <tr> <td rowspan="10" style="writing-mode: vertical-rl; text-orientation: mixed; font-weight: bold; font-size: 2em;">F E E S</td> <th>Description</th> <th>Quantity</th> <th>Amount</th> </tr> <tr> <td>Plan Check Fee</td> <td></td> <td>\$104.92</td> </tr> <tr> <td>One-Stop Permit Center Surcharge</td> <td></td> <td>\$3.17</td> </tr> <tr> <td>Building Permit Document Retention Fee</td> <td>1</td> <td>\$5.00</td> </tr> <tr> <td>Building Technology Fee</td> <td>1</td> <td>\$10.00</td> </tr> <tr> <td>BSASRF State Fee</td> <td></td> <td>\$1.00</td> </tr> <tr> <td>Issuance Fee</td> <td>1</td> <td>\$35.00</td> </tr> <tr> <td>Building Permit Fee</td> <td></td> <td>\$158.25</td> </tr> <tr> <td>Cultural Arts Fee, Valuation</td> <td></td> <td>\$4.75</td> </tr> <tr> <td>General Plan Update Fee, Valuation</td> <td></td> <td>\$9.50</td> </tr> <tr> <td>TOTAL</td> <td></td> <td>\$331.59</td> </tr> </table>			F E E S	Description	Quantity	Amount	Plan Check Fee		\$104.92	One-Stop Permit Center Surcharge		\$3.17	Building Permit Document Retention Fee	1	\$5.00	Building Technology Fee	1	\$10.00	BSASRF State Fee		\$1.00	Issuance Fee	1	\$35.00	Building Permit Fee		\$158.25	Cultural Arts Fee, Valuation		\$4.75	General Plan Update Fee, Valuation		\$9.50	TOTAL		\$331.59
F E E S	Description	Quantity	Amount																																						
	Plan Check Fee		\$104.92																																						
	One-Stop Permit Center Surcharge		\$3.17																																						
	Building Permit Document Retention Fee	1	\$5.00																																						
	Building Technology Fee	1	\$10.00																																						
	BSASRF State Fee		\$1.00																																						
	Issuance Fee	1	\$35.00																																						
	Building Permit Fee		\$158.25																																						
	Cultural Arts Fee, Valuation		\$4.75																																						
	General Plan Update Fee, Valuation		\$9.50																																						
TOTAL		\$331.59																																							
Floor Area(sq. ft)		Residential/Commercial Commercial																																							
Job Description REPLACE STOREFRONT GLAZING PER ATTACHED/APPROVED PLAN.																																									
DECLARATION																																									
I certify that I have read this application/permit and state that the information on all pages of this document is correct I agree to comply with all City and County ordinances and State laws relating to building construction, and hereby authorize representatives of this City and County to enter upon the above mentioned property for inspection purposes																																									
<input checked="" type="checkbox"/> Applicant's Signature <u>[Signature]</u>		Print Name <u>DUNG LE</u> Date <u>08/30/16.</u>																																							

This is a building permit when properly filled out, signed and validated, and is subject to expiration if work thereunder is suspended for 180 days.

Permit Type: BLDG

ORIGINAL



Welcome,
Isabella
Zandvliet!



Building Division Invoice

Search



11222 Acacia Parkway, Garden Grove, CA 92840 TEL.(714)741-5307

[[Back To Details](#)] [[Enter Cash Receipt Information](#)] [[Print Invoice](#)]

Invoice Number: 29836
 Site Address: 13916 BROOKHURST ST
 REPLACE STOREFRONT
 Work Description: GLAZING PER ATTACHED/APPROVED PLAN Permit Number: 16-2587
 Application: A-228450 Total Amount of Invoice: \$331.59
 Invoice Date: 8/30/16 04:28:35 PM

Finance Code Information

Finance Code Description	Finance Code Number	Amount
1 General Plan	B907	\$9.50
2 Cultural Arts	B908	\$4.75
3 Building Plan Check	B910	\$104.92
4 Permit	B915	\$161.42
5 Issuance	B920	\$35.00
6 BSASRF State Fee	B938	\$1.00
7 Building Technology	B200	\$10.00
8 Document Retention Fee	B944	\$5.00
Total		\$331.59

Application Contacts

Role	Name	Address	City	Phone
1 Applicant Contractor	DUNG LE	10718 WESTMINSTER ST, #A	WESTMINSTER	714-981-4098
2 Owner	CHOE,WINSTON TRUST	13916 BROOKHURST ST	Garden Grove	



**CITY OF GARDEN GROVE
BUILDING SERVICES**

**13916 BROOKHURST
ST**

**PERMIT#:16-1161
ISSUED:4/13/16**

General Info : 714-741-5307

Inspection Requests : 855-380-8758

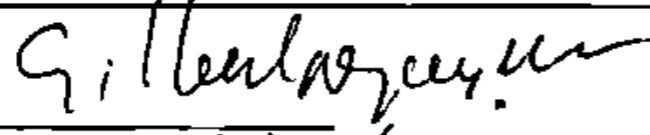
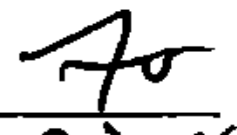
Applicant MICHEL KHAC SU		Telephone 714-724-0142	Zip 92843	Building Address 13916 BROOKHURST ST	
Address 10342 WESTMINSTER #4		City GARDEN GROVE	State	Suite/Unit/Building STE A & B	
State Licence 908932	Expires N/A	City Licence	Expires	TYPE Tenant Improvement	ISSUED BY Lizabeth Vasquez
Contractor MICHEL KHAC SU		Telephone 714-724-0142	Zip 92843	Inspector Dist N16	Parcel Number 09934413
Address 10342 WESTMINSTER #4		City GARDEN GROVE	State	LOT	TRACT
State Licence 908932	Expires N/A	City Licence	Expires	Valuation \$15,000.00	
Floor Area(sq. ft.)	Residential/Commercial Commercial				
Job Description COMBINING STE A & B TO ENLARGE (E) COFFEE SHOP (STE A)-ENLARGING KIT AREA/SEATING AREA/NEW WALK IN COOLER & NEW WALK IN FREEZER					
DECLARATION I certify that I have read this application/permit and state that the information on all pages of this document is correct I agree to comply with all City and County ordinances and State laws relating to building construction, and hereby authorize representatives of this City and County to enter upon the above mentioned property for inspection purposes					
X Applicant's Signature 		Inspector's Signature 			
Print Name <u>GILBERT NGUYEN</u>		Date <u>4-13-16</u>			
		Date <u>12-22-16</u>			

**Permit Type:
BLDG/PLUMB/MECH/ELEC**



**CITY OF GARDEN GROVE
BUILDING SERVICES**

**13916 BROOKHURST
ST**

**PERMIT#:16-1161
ISSUED:4/13/16**

**General Info : 714-741-5307
Inspection Requests : 855-380-8758**

**F
E
E
S**

Description	Quantity	Amount
Engineering Plan Check - Tenant Improvement	1	\$39.64
Fire Plan Check Fee - Commercial TI under 6000 sqft	1	\$39.64
Plan Check Fee		\$175.20
One-Stop Permit Center Surcharge		\$5.29
Cultural Arts Fee, Valuation		\$9.42
Gas System	7	\$25.50
Industrial waste pre-treatment interceptor, sand trap, receptor	1	\$95.00
Urinal	1	\$9.50
Kitchen Sink	1	\$9.50
Lavatory	1	\$9.50
Ventilation/Exhaust, Type I Commercial Ventilation Hood	1	\$45.00
Commercial range hood (including duct and fan)	1	\$10.00
Install/Relocation of floor furnace, suspended heater, wall heater, unit heater	1	\$30.00
Ducts	1	\$12.00
Subpanel/Distribution Panels (single phase)	1	\$30.00
Kitchen Fan	1	\$4.50
Fixtures, Mercury, Quartz, ect	2	\$4.00
Electrical Meter Reset	1	\$30.00
General Plan Update Fee, Valuation		\$18.83
Building Permit Document Retention Fee	1	\$5.00
Building Technology Fee	1	\$10.00
Plan Retention	9	\$36.00
BSASRF State Fee		\$1.00
Plumbing Plan Check Fee	1	\$126.65
Mechanical Plan Check Fee	1	\$82.45
Electrical Plan Check Fee	1	\$80.00
Planning Plan Check Fee - Tenant Improvement	1	\$50.00
Issuance Fee	1	\$35.00
Building Permit Fee		\$264.25
Plan Check Fee - Disabled Access (Commercial)	1	\$17.52

Permit Type:

BLDG/PLUMB/MECH/ELEC



**CITY OF GARDEN GROVE
BUILDING SERVICES**

**13916 BROOKHURST
ST**

**PERMIT#:16-1161
ISSUED:4/13/16**

**General Info : 714-741-5307
Inspection Requests : 855-380-8758**

	Plan Check Fee - Energy Conservation (Commercial)	1	\$17.52
	TOTAL		\$1,327.91

This is a building permit when properly filled out, signed and validated, and is subject to expiration if work thereunder is suspended for 180 days.

**Permit Type:
BLDG/PLUMB/MECH/ELEC**



Welcome,
Isabella
Zandvillet!



Building Division Invoice

Search



11222 Acacia Parkway, Garden Grove, CA 92840 TEL:(714)741-5307

[[Back To Details](#)] [[Enter Cash Receipt Information](#)] [[Print Invoice](#)]

Invoice Number	28055		
Site Address	13916 BROOKHURST ST		
	COMBINING STE A & B TO		
	ENLARGE (E) COFFEE		
	SHOP (STE A)-ENLARGING		
Work Description:	KIT AREA/SEATING	Permit Number	16-1161
	AREA/NEW WALK IN		
	COOLER & NEW WALK IN		
	FREEZER		
Application:	A-224735	Total Amount of Invoice:	\$748.39
Invoice Date:	4/13/16 03:38:46 PM		
Plan Check Number:	PC2015-621		

Finance Code Information

Finance Code Description	Finance Code Number	Amount
1 Permit	B915	\$269.54
2 Issuance	B920	\$35.00
3 MECH Plan Check	H910	\$2.45
4 PLUM Plan Check	P910	\$46.65
5 BSASRF State Fee	B938	\$1.00
6 Plan Retention	B939	\$36.00
7 Building Technology	B200	\$10.00
8 Document Retention Fee	B944	\$5.00
9 Cultural Arts	B908	\$9.42
10 General Plan	B907	\$18.83
11 Electrical Meter Re-Set	E121	\$30.00
12 Fixtures, Merc. Quartz, Etc.	E170	\$4.00
13 Kitchen Fan	E240	\$4.50
14 Sub-Panel	E145	\$30.00
15 Ducts	H116	\$12.00
16 Inst/Relocation Susp Htr	H120	\$30.00
17 Comm Rnge Hood W/Duct&Fan	H150	\$10.00
18 Type 1 Coml Vent Hood	H165	\$45.00
19 Lavatory	P120	\$9.50
20 Kitchen Sink	P125	\$9.50
21 Unnal	P165	\$9.50
22 Grease/Sand Traps	P185	\$95.00
23 Gas Syst. Outl. (Up To 5)	P170	\$25.50
Total		\$748.39

Application Contacts

Role	Name	Address	City	Phone
Applicant 1 Contractor Designer	MICHEL KHAC SU	10342 WESTMINSTER #4	GARDEN GROVE	714-724-0142

PERMIT WORK SHEET

City of Garden Grove
Permit Worksheet

ELECTRICAL

Description	No.	Description	No.
Residential, R1, Occ., sq.ft.		Power apparatus, 1hp, 1kw or 1kva, max	
Garage, Residential, U1 Occ., sq.ft.		Power apparatus, 10hp, 10kw, 10kva, max	
Service meter, 1 or 3 phase, 600V max, 200 amps max		Power apparatus, 50hp, 50kw, or 50kva, max	
Electrical Meter Re-set	01	Power apparatus, to 100hp, 100kw, or 100kva	
Service, 600V max, 200 to 1000 amps		Power apparatus, over 100hp, 100kw, 100kva	
Service, over 600V or over 1000 amps		Time clock	
Temporary Power Pole		Light & Marquees (1 branch)	
Distribution System on Constr. Site, ea. pole		Sign hookup (Additional)	
Pole, power, light, etc.		Customer Metering device (1 thru 5)	
Pole, power, light, etc. additional		Customer Metering device (over five)	
Sub panel	01	Swimming pool & spa	
Sub panel (3-phase)		Sign branch circuits	
Outlets, 1 to 10		Generator, thru 10kw	
Outlets, additional more than 10		Generator, thru 50kw	
Fixtures, 1 to 10		Generator, over 50kw	
Fixtures, additional more than 10	02	Generator, over 100kw	
Fixtures; Mercury, Quartz, etc.		Kitchen fan	01
Heater, through 1650 watts		Distribution panel	
Heater, over 1650 watts		Motion Picture machine	
Radiant heater, per 1000 watts		Portable X-ray machine	
Residential Appliance		Sterilizer	
Non-Residential Appliance	01	Dental unit	
Hot Water Heater		Murphy type kitchen	
Commercial Oven thru 50,000 watts		Busways, special raceways	
Commercial Oven over 50,000 watts		Switchboard, motor control center, etc.	
Cooking Device thru 10,000 watts		Switchboard, Ea. Additional over one	
Cooking Device over 10,000 watts			

MECHANICAL

Description	No.	Description	No.
Furnace to 100,000 BTU	01	Boiler, comp or absorp, unit to 15hp or 500,000 BTU	
Furnace, 100,001 to 1,000,000 BTU		Boiler, comp or absorp, unit to 30hp or 1,000,000 BTU	
Furnace over 1,000,000 BTU		Boiler, comp or absorp, unit to 50hp or 1,750,000 BTU	
Ducts	02	Boiler, comp or absorp, unit over 50hp over 1,750,000	
Furnace, to 2,000,000 BTU		Absorption system, to 1,000,000 BTU	
Installation or relocation of a heater (susp., Wall, etc)	01	Absorption system, to 1,750,000 BTU	
Air Conditioning, condensing unit, to 5 tons		Heat pumps, to 100,000 BTU	
Air Conditioning, condensing unit, to 15 tons		Heat pumps, to 500,000 BTU	
Installation of appliance vent (not part of appl permit)		A.C. condensing unit to 5 tons	
Repair of alter a cooling/heating system		A. C. condensing unit, 15 tons	
Incidental gas piping (first five outlets)		A.C. condensing unit, over 15 ton	
Incidental gas piping (ea. after Five fixtures)		Evaporative cooler	
Commercial range hood (including duct & fan)	01	Air handling unit, up to 2000 CFM	
Vent fan to single duct (include, residential range hood)		Air handling unit, up to 10,000 CFM	
Separate ventilating system (range hood)		Air handling unit, over 10,000 CFM	
Type I commercial vent hood	01	Fire dampers	
Type II commercial vent hood		Decorative fireplace	
Boiler, comp or absorp, unit to 3hp or 100,000 BTU		Appliances or equipment not mentioned	

SEE BACK FOR PLUMBING

PLUMBING

Description	No.	Description	No.
Water closet, Bidet		Industrial clarifiers	
Bathtub		Private sewer disposal system	
Shower		Rainwater drain	
Lavatory	/	Swimming pool piping	
Kitchen sink		Occupancy termination of a sewer system	
Garbage disposal		Automatic washing machine	
Laundry tub or tray		Water lateral	
Water heater		Backflow protection device, up to 2 in. dia.	
Floor sink		Backflow protection device, over 2 in. dia.	
Floor drain		Water piping, repair, repipe of S.F.D.	
Dishwasher		Water piping, repair, repipe S.F.D. (additional 100 ft)	
Urinal	01	Lawn sprinklers (single family dwelling) Vac	
Gas system outlets (through 5)		Ea additional backflow device	
Gas system outlets (over 5)	01	Lawn sprinklers (other than S.F.D.) atmospheric	
Building sewer (first 100 ft.)		Ea additional (non residential)	
Building sewer (each additional 100 ft.)		Occupancy termination of water service piping	
Cesspool/Leachline		On site hydrant	
Ea addition Cesspool/Leachline		Ea additional Hydrant	
Grease interceptor/Sand traps	01	Other fixture (not specified)	



**CITY OF GARDEN GROVE
BUILDING SERVICES**

**13916 BROOKHURST
ST**

**PERMIT#:16-1161
ISSUED:4/13/16**

**General Info : 714-741-5307
Inspection Requests : 855-380-8758**

Applicant MICHEL KHAC SU			Telephone 714-724-0142	Zip 92843	Building Address 13916 BROOKHURST ST			
Address 10342 WESTMINSTER #4			City GARDEN GROVE	State	Suite/Unit/Building STE A & B			
State Licence 908932	Expires N/A	City Licence	Expires	TYPE Tenant Improvement		ISSUED BY Lizabeth Vasquez		
Contractor MICHEL KHAC SU			Telephone 714-724-0142	Zip 92843	Inspector Dist N16	Parcel Number 09934413	LOT	TRACT
Address 10342 WESTMINSTER #4			City GARDEN GROVE	State	Valuation \$15,000.00			
State Licence 908932	Expires N/A	City Licence	Expires	Final Inspector's Signature <u><i>Liz Vasquez</i></u> Date <u>11-29-16</u>				
Floor Area(sq. ft.)	Residential/Commercial Commercial							
Job Description COMBINING STE A & B TO ENLARGE (E) COFFEE SHOP (STE A)-ENLARGING KIT AREA/SEATING AREA/NEW WALK IN COOLER & NEW WALK IN FREEZER								
DECLARATION I certify that I have read this application/permit and state that the information on all pages of this document is correct. I agree to comply with all City and County ordinances and State laws relating to building construction, and hereby authorize representatives of this City and County to enter upon the above mentioned property for inspection purposes								
X Applicant's Signature <u><i>Michel Khac Su</i></u> Print Name <u>TRANG HUYNH</u> Date <u>12/6/16.</u>								

**Permit Type:
BLDG/ELEC/MECH/PLUMB**



**CITY OF GARDEN GROVE
BUILDING SERVICES**

**13916 BROOKHURST
ST**

**PERMIT#:16-1161
ISSUED:4/13/16**

**General Info : 714-741-5307
Inspection Requests : 855-380-8758**

**F
E
E
S**

Description	Quantity	Amount
Engineering Plan Check - Tenant Improvement	1	\$39.64
Fire Plan Check Fee - Commercial TI under 6000 sqft	1	\$39.64
Cultural Arts Fee, Valuation		\$9.42
Plan Check Fee		\$175.20
One-Stop Permit Center Surcharge		\$5.29
General Plan Update Fee, Valuation		\$18.83
Ad-hoc	1	\$135.00
BSASRF State Fee		\$1.00
Building Permit Document Retention Fee	1	\$5.00
Building Technology Fee	1	\$10.00
Plan Retention	9	\$36.00
Building Permit Fee		\$264.25
Electrical Plan Check Fee	1	\$80.00
Planning Plan Check Fee - Tenant Improvement	1	\$50.00
Issuance Fee	1	\$35.00
Plan Check Fee - Disabled Access (Commercial)	1	\$17.52
Plan Check Fee - Energy Conservation (Commercial)	1	\$17.52
Mechanical Plan Check Fee	1	\$82.45
Plumbing Plan Check Fee	1	\$126.65
Electrical Meter Reset	1	\$30.00
Fixtures, Mercury, Quartz, ect	2	\$4.00
Kitchen Fan	1	\$4.50
Subpanel/Distribution Panels (single phase)	1	\$30.00
Ducts	1	\$12.00
Install/Relocation of floor furnace, suspended heater, wall heater, unit heater	1	\$30.00
Commercial range hood (including duct and fan)	1	\$10.00
Ventilation/Ehaust, Type I Commercial Ventilation Hood	1	\$45.00
Lavatory	1	\$9.50
Kitchen Sink	1	\$9.50
Urinal	1	\$9.50

Permit Type:

BLDG/ELEC/MECH/PLUMB



**CITY OF GARDEN GROVE
BUILDING SERVICES**

**13916 BROOKHURST
ST**

**PERMIT#:16-1161
ISSUED:4/13/16**

**General Info : 714-741-5307
Inspection Requests : 855-380-8758**

	Industrial waste pre-treatment interceptor, sand trap, receptor	1	\$95.00
	Gas System	7	\$25.50
	TOTAL		\$1,462.91

This is a building permit when properly filled out, signed and validated, and is subject to expiration if work thereunder is suspended for 180 days.

**Permit Type:
BLDG/ELEC/MECH/PLUMB**



**CITY OF GARDEN GROVE
BUILDING SERVICES**

**13916 BROOKHURST
ST**

**PERMIT#:15-1618
ISSUED:6/30/15**

**General Info : 714-741-5307
Inspection Requests : 855-380-8758**

Applicant PURE AIR			Telephone 714-537-9751	Zip 92840	Building Address 13916 BROOKHURST ST		
Address 12700 PINEHURST CT			City GARDEN GROVE	State CA	Suite/Unit/Building		
State Licence 792214 C10		Expires N/A	City Licence Expires		TYPE Mechanical Permit		ISSUED BY Aaron Hodson
Contractor PURE AIR			Telephone 714-537-9751	Zip 92840	Inspector Dist. N16	Parcel Number 09934413	LOT TRACT
Address 12700 PINEHURST CT			City GARDEN GROVE	State CA	Valuation \$0.00		
State Licence 792214 C10		Expires N/A	City Licence Expires		Final Inspector's Signature <u>[Signature]</u> Date <u>7.21.15</u>		
Floor Area(sq. ft.)		Residential/Commercial Commercial					
Job Description CHANGE OUT HEAT PUMP (COMBO HEAT AND AIR UNIT) AT SAME LOCATION AND CAPACITY (LIKE FOR LIKE)							
DECLARATION							
<small>I certify that I have read this application/permit and state that the information on all pages of this document is correct. I agree to comply with all City and County ordinances and State laws relating to building construction, and hereby authorize representatives of this City and County to enter upon the above mentioned property for inspection purposes.</small>							
X Applicant's Signature <u>[Signature]</u>		Print Name <u>THANK LANGLEY</u> Date <u>6/30/15</u>					
F E E S				Description		Quantity	Amount
				Building Permit Document Retention Fee		1	\$5.00
				Building Technology Fee		1	\$10.00
				Heat pumps, to , BTU		1	\$9.00
				Air Conditioning, condensing unit, to 5 tons		1	\$10.00
				Issuance Fee		1	\$35.00
				TOTAL			\$69.00

This is a building permit when property filled out, signed and validated, and is subject to expiration if work thereunder is suspended for 180 days.

Permit Type: MECH

ORIGINAL

CITY OF GARDEN GROVE - COMMUNITY DEVELOPMENT DEPARTMENT

Plot Plan Form

Planning Action: Approved	Zone: C-2	Coverage:
Approved By: CO	Date: 6/30/15	Increase:
Remarks:		

Job Address:	Permit No.: 15-1618			
Assessor Parcel No.:	Tract & Lot #:			
Occupancy:	Const. Type:	Value:		
<input type="checkbox"/> New	<input type="checkbox"/> Alter	<input type="checkbox"/> Add	<input type="checkbox"/> Repair	<input type="checkbox"/> Demo

Job Description: *changing out old HPupp @ same location and capacity (4-TON) Like for Like replacement*

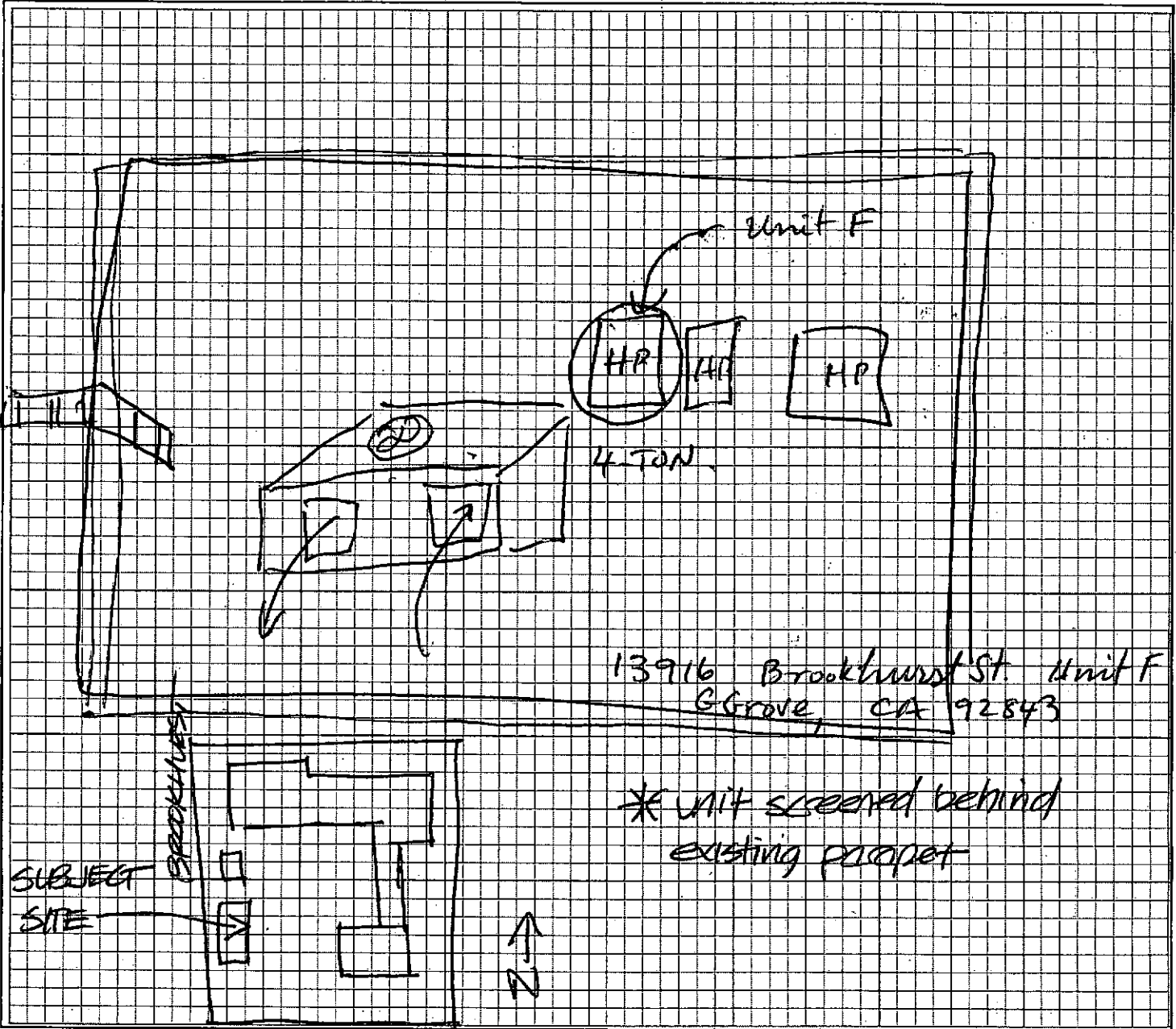

I certify the information is true and correct.

Owner's Name (print) _____ Signature (owner/agent) *Thomh Ly...* Date **6/30/15**

White: Inspection Yellow: Assessor Pink: Permittee



**CITY OF GARDEN GROVE
BUILDING SERVICES**

**13916 BROOKHURST
ST**

PERMIT#:13-0426

ISSUED:3/1/13

General Info : 714-741-5307

Inspection Requests : 714-741-5332

Owner CHOE, WINSTON TRUST			Telephone	Zip 92843	Building Address 13916 BROOKHURST ST		
Address 13916 BROOKHURST ST		City Garden Grove	State CA	Suite/Unit/Building UNIT E			
Applicant D S G SIGNS-GRAPHIC			Telephone 677-0506	Zip	TYPE Sign		
Address 14872 DILLOW ST		City WESTMINSTER	State CA	ISSUED BY Joanne Chung			
State Licence 892165		Expires N/A	City Licence		Expires	Inspector Dist. N16	Parcel Number 09934413
						LOT	TRACT
Contractor D S G SIGNS-GRAPHIC			Telephone 677-0506	Zip	Valuation \$1,000.00		
Address 14872 DILLOW ST		City WESTMINSTER	State CA	Final			
State Licence 892165		Expires N/A	City Licence		Expires	Inspector's Signature _____ Date _____	
Floor Area(sq. ft.)		Residential/Commercial Commercial					
Job Description 1 ILLUM WALL SIGN							
DECLARATION							
I certify that I have read this application/permit and state that the information on all pages of this document is correct. I agree to comply with all City and County ordinances and State laws relating to building construction, and hereby authorize representatives of this City and County to enter upon the above mentioned property for inspection purposes.							
<input checked="" type="checkbox"/> Applicant's Signature <u>Tricia Tran</u> Print Name <u>TRICIA TRAN</u> Date <u>3/1/13</u>							
F E E S				Description		Quantity	Amount
				Building Permit Document Retention Fee		1	\$5.00
				Building Technology Fee		1	\$10.00
				BSASRF State Fee			\$1.00
				Signs: outline lighting and marquees		1	\$50.00
				Issuance Fee		1	\$35.00
				One-Stop Permit Center Surcharge			\$1.10
				Building Permit Fee			\$55.00
				Plan Check Fee			\$60.00
				Cultural Arts Fee, Valuation			\$1.25
General Plan Update Fee, Valuation			\$2.50				
TOTAL			\$220.85				

This is a building permit when properly filled out, signed and validated, and is subject to expiration if work thereunder is suspended for 180 days.

EXPIRED

Permit Type: BLDG/ELEC

ORIGINAL

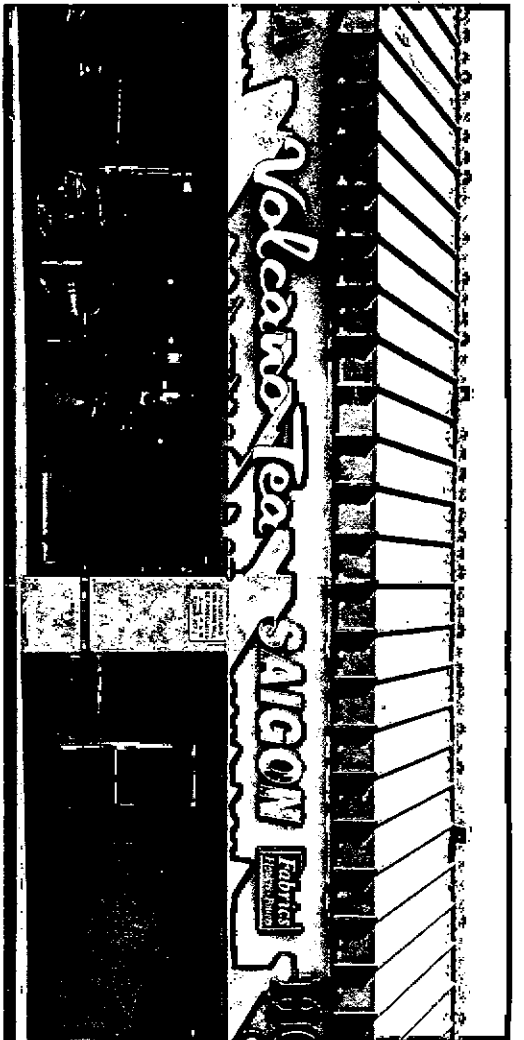

FRONT ELEVATION



REAR ELEVATION

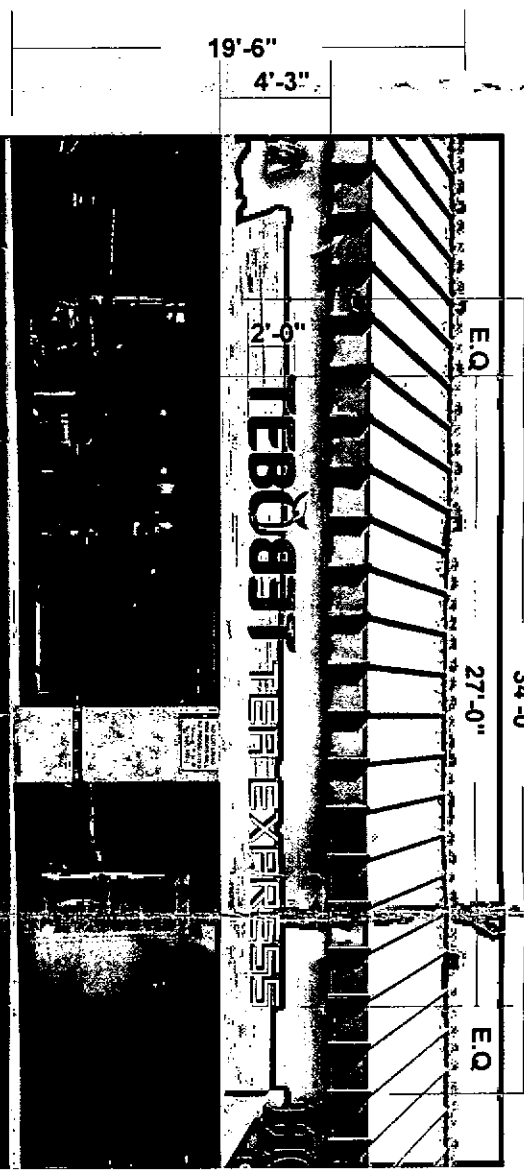

FRONT ELEVATION



REAR ELEVATION

THIS ORIGINAL DESIGN IS THE SOLE PROPERTY OF DSG SIGNS GRAPHICS. IT CANNOT BE REPRODUCED, COPY, OR EXHIBITED IN WHOLE OR PART WITHOUT FIRST OBTAINING WRITTEN CONSENT FROM DSG SIGNS GRAPHICS, INC.

Lic # 811396 Lic # E295227
DSG
 SIGNS GRAPHICS
 DESIGN MANUFACTURING INSTALLATION
 14872 DILLOW ST. WESTMINSTER, CA 92683
 Tel : 714 - 677 0506 * Fax : 714 - 677 0462

Project : **TEBÖBAT**
 Address : 13916 BROOKHURST ST.
 GARDEN GROVE, CA
 Tell : _____

Date : 1-06-2013
 Drawing # : 10315
 Design by : TP
 Scale : 3/16" = 1'-0"
 Page : 1 of 3

CUSTOMER APPROVAL
 GARDEN GROVE
 P.O. Box 3070
 Garden Grove,
 California 92842
 X _____

PROPERTY OWNER APPROVAL
 ON: X *[Signature]*
AUTHORIZED APPROVAL
 I HAVE REVIEWED AND APPROVED THE SIGN DETAILED HEREIN TO BE FABRICATED PER THE SPECIFICATIONS SHOWN ON THIS DRAWING.

LAND USE

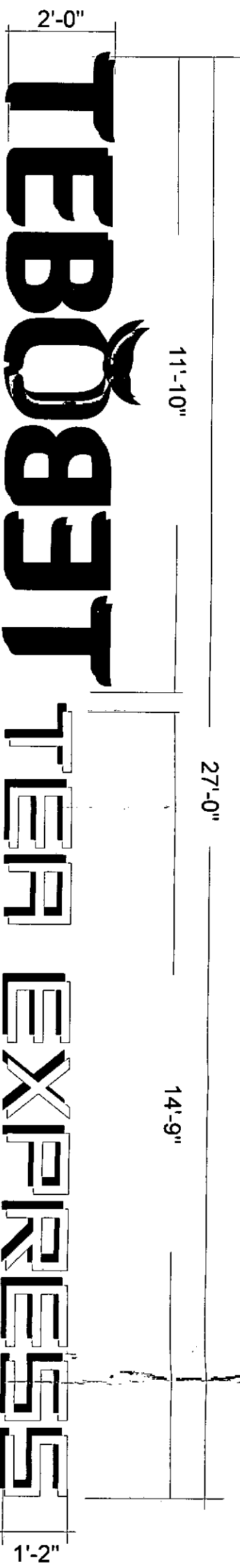

ILLUMINATED CHANNEL LETTERS

LEASE FRONTAGE: 34'-0"
ALLOWANCE SIGN ARE: 40 87 SQ. FT.

SPECIFICATIONS

1. PROPOSED SIGN IS ILLUMINATED ALUMINUM PAN CHANNEL LETTERS.
2. COLOR "TEBÖBAT" TO BE WHITE ACRYLICS WITH FIRST SURFACE GLOSS BE VINYL & 3/4" BLACK TRIM CAP. COLOR "TEPA EXPERIES" TO BE WHITE ACRYLICS.
3. RETURNS: 5" DEEP ALLIANCE .090 BLACK ALUMINUM PRE-FINISHED
4. ILLUMINATION: LED RWWHITE
5. CHANNEL LETTERS SHALL BE MOUNTED ON THE WALL.
6. MIN. 3-5 (#10 X 1 1/2") SCREW PER LETTER WITH PLASTICS ANCHORS
7. 20 AMP CIRCUIT BREAKER.
8. ALL COMPONENTS TO BE U.L. LISTED.

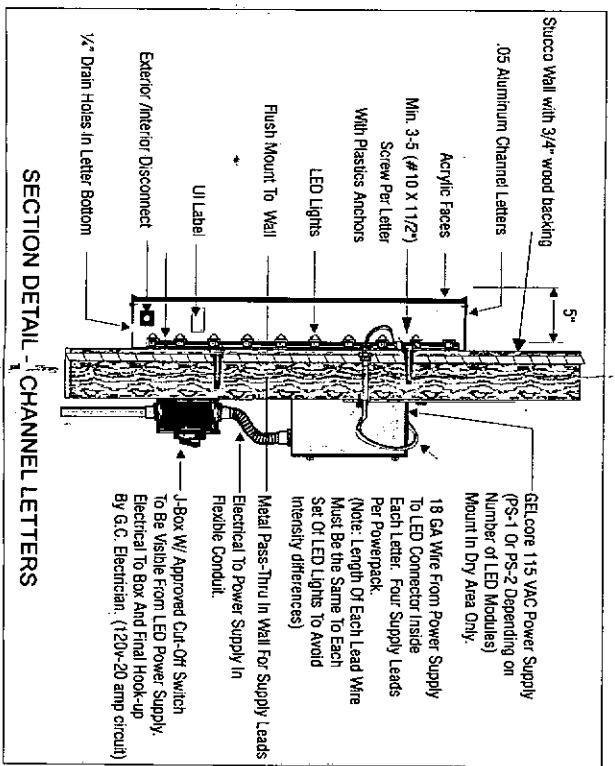
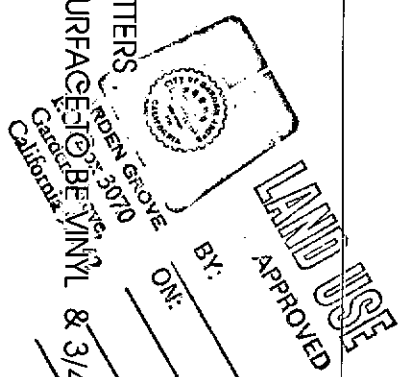

THIS ORIGINAL DESIGN IS THE SOLE PROPERTY OF DSG SIGNS GRAPHICS. IT CANNOT BE REPRODUCED, COPY OR EXHIBITED IN WHOLE OR PART WITHOUT FIRST OBTAINING WRITTEN CONSENT FROM DSG SIGNS GRAPHICS, INC.

Lic # 811396 # E235227
DSG SIGNS GRAPHICS
 DESIGN
 MANUFACTURING
 INSTALLATION
 14872 DILLOW ST. WESTMINSTER, CA 92683
 Tel: 714-677-0506 * Fax: 714-677-0462

Project: **TEBÖBAT**
 Address: 13916 BROOKHURST ST.
 GARDEN GROVE, CA
 Tell: _____

Date: 1-06-2013
 Drawing #: 10315
 Design by: T.P
 Scale: 3/16" = 1'-0"
 Page: 1 of 3

CUSTOMER APPROVAL: _____
 PROPERTY OWNER APPROVAL: _____
 AUTHORIZED APPROVAL: _____
 I HAVE REVIEWED AND APPROVED THE SIGN DETAILED HEREIN TO BE FABRICATED PER THE SPECIFICATIONS SHOWN ON THIS DRAWING

TEBÖBET

TERA

EXPERIES

ILLUMINATED CHANNEL LETTERS

LEASE FRONTAGE: 34'-0"
ALLOWANCE SIGN ARE: 40.87 SQ. FT.

11'-10"

27'-0"

14'-9"

SPECIFICATIONS

1. PROPOSED SIGN IS ILLUMINATED ALUMINUM PAN CHANNEL LETTERS.
2. COLOR "TEBÖBET" TO BE WHITE ACRYLICS WITH FIRST SURFACE TO BE VINYL & 3/4" BLACK TRIM CAP.
- COLOR "TERA EXPERIES" TO BE WHITE ACRYLICS.
3. RETURNS: 5" DEEP ALLIANCE .090 BLACK ALUMINUM PRE-FINISHED
4. ILLUMINATION: LED RWHITE
5. CHANNEL LETTERS SHALL BE MOUNTED ON THE WALL.
6. MIN. 3-5 (#10 x 1 1/2") SCREW PER LETTER WITH PLASTICS ANCHORS
7. 20 AMP CIRCUIT BREAKER.
8. ALL COMPONENTS TO BE U.L. LISTED.

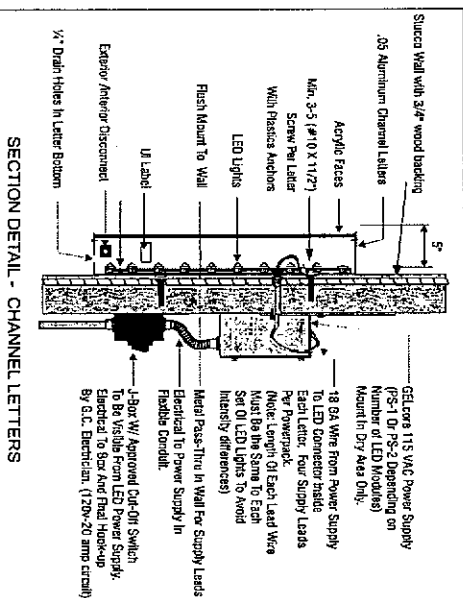

THIS ORIGINAL DESIGN IS THE SOLE PROPERTY OF DSG SIGNS GRAPHICS. IT CANNOT BE REPRODUCED, COPY, OR EXHIBITED IN WHOLE OR PART WITHOUT FIRST OBTAINING WRITTEN CONSENT FROM DSG SIGNS GRAPHICS, INC.

Lic # 811396 # E235227
DESIGN
14872 DILLOW ST. WESTMINSTER, CA 92683
Tel: 714-677-0506 # Fax: 714-677-0462

Project: **TEBÖBET**
Address: 13916 BROOKHURST ST.
GARDEN GROVE, CA
Tel:

Date: 1-06-2013
Drawing #: 10315
Design by: TP
Scale: 3/16" = 1'-0"
Page: 1 of 3

CUSTOMER APPROVAL: _____
PROPERTY OWNER APPROVAL: _____
AUTHORIZED APPROVAL: _____
I HAVE REVIEWED AND APPROVED THE SIGN DETAILED HEREIN TO BE FABRICATED PER THE SPECIFICATIONS SHOWN ON THIS DRAWING.



**CITY OF GARDEN GROVE
BUILDING SERVICES**

**13916 BROOKHURST
ST**

**PERMIT#:13-0543
ISSUED:3/19/13**

**General Info : 714-741-5307
Inspection Requests : 714-741-5332**

Owner CHOE, WINSTON TRUST		Telephone	Zip 92843	Building Address 13916 BROOKHURST ST																																			
Address 13916 BROOKHURST ST		City Garden Grove	State CA	Suite/Unit/Building UNIT E																																			
Applicant UNITED FIRE & SAFETY CO.		Telephone 951-675-0220	Zip 92503	TYPE Fire Sprinklers	ISSUED BY Joanne Chung																																		
Address 12305 DOHERTY ST		City RIVERSIDE	State CA	Inspector Dist. N16	Parcel Number 09934413																																		
State Licence 621096 C16		Expires N/A	City Licence	Expires	LOT																																		
Contractor UNITED FIRE & SAFETY CO.		Telephone 951-675-0220	Zip 92503	Valuation \$2,500.00																																			
Address 12305 DOHERTY ST		City RIVERSIDE	State CA	Final Inspector's Signature <i>[Signature]</i> Date <i>4/25/13</i>																																			
State Licence 621096 C16		Expires N/A	City Licence	Expires																																			
Floor Area(sq. ft.)	Residential/Commercial Commercial																																						
Job Description HOOD FIRE SUPPRESSION SYSTEM UL300																																							
<p align="center">DECLARATION</p> <p>I certify that I have read this application/permit and state that the information on all pages of this document is correct. I agree to comply with all City and County ordinances and State laws relating to building construction, and hereby authorize representatives of this City and County to enter upon the above mentioned property for inspection purposes.</p>																																							
<input checked="" type="checkbox"/> Applicant's Signature <i>[Signature]</i> Print Name <u>JOHN TAN</u> Date <u>3/19/13</u>																																							
		<table border="1"> <tr> <td rowspan="10" style="writing-mode: vertical-rl; text-orientation: mixed;">F E E S</td> <td>Description</td> <td>Quantity</td> <td>Amount</td> </tr> <tr> <td>Cultural Arts Fee, Valuation</td> <td></td> <td>\$2.42</td> </tr> <tr> <td>Plan Check Fee</td> <td></td> <td>\$69.78</td> </tr> <tr> <td>One-Stop Permit Center Surcharge</td> <td></td> <td>\$2.11</td> </tr> <tr> <td>General Plan Update Fee, Valuation</td> <td></td> <td>\$4.83</td> </tr> <tr> <td>Building Permit Document Retention Fee</td> <td>1</td> <td>\$5.00</td> </tr> <tr> <td>Building Technology Fee</td> <td>1</td> <td>\$10.00</td> </tr> <tr> <td>BSASRF State Fee</td> <td></td> <td>\$1.00</td> </tr> <tr> <td>Issuance Fee</td> <td>1</td> <td>\$35.00</td> </tr> <tr> <td>Building Permit Fee</td> <td></td> <td>\$105.25</td> </tr> <tr> <td>TOTAL</td> <td></td> <td>\$235.39</td> </tr> </table>				F E E S	Description	Quantity	Amount	Cultural Arts Fee, Valuation		\$2.42	Plan Check Fee		\$69.78	One-Stop Permit Center Surcharge		\$2.11	General Plan Update Fee, Valuation		\$4.83	Building Permit Document Retention Fee	1	\$5.00	Building Technology Fee	1	\$10.00	BSASRF State Fee		\$1.00	Issuance Fee	1	\$35.00	Building Permit Fee		\$105.25	TOTAL		\$235.39
F E E S	Description	Quantity	Amount																																				
	Cultural Arts Fee, Valuation		\$2.42																																				
	Plan Check Fee		\$69.78																																				
	One-Stop Permit Center Surcharge		\$2.11																																				
	General Plan Update Fee, Valuation		\$4.83																																				
	Building Permit Document Retention Fee	1	\$5.00																																				
	Building Technology Fee	1	\$10.00																																				
	BSASRF State Fee		\$1.00																																				
	Issuance Fee	1	\$35.00																																				
	Building Permit Fee		\$105.25																																				
TOTAL		\$235.39																																					

This is a building permit when properly filled out, signed and validated, and is subject to expiration if work thereunder is suspended for 180 days.

Permit Type: BLDG

ORIGINAL



**CITY OF GARDEN GROVE
BUILDING SERVICES**

**13916 BROOKHURST
ST**

**PERMIT#:12-2396
ISSUED:11/29/12**

**General Info : 714-741-5307
Inspection Requests : 714-741-5332**

Owner CHOE, WINSTON TRUST		Telephone	Zip 92843	Building Address 13916 BROOKHURST ST	
Address 13916 BROOKHURST ST		City Garden Grove	State CA	Suite/Unit/Building D & E	
Applicant WIN NGUYEN CONSTRUCTION		Telephone 326-3124	Zip 92703	TYPE Tenant Improvement	
Address 4021 CELESTE		City SANTA ANA	State	ISSUED BY Joanne Chung	
State Licence 955157	Expires N/A	City Licence	Expires	Inspector Dist. N16	Parcel Number 09934413
Contractor WIN NGUYEN CONSTRUCTION		Telephone 326-3124	Zip 92703	Valuation \$100,000.00	
Address 4021 CELESTE		City SANTA ANA	State	Final	
State Licence 955157	Expires N/A	City Licence	Expires	Inspector's Signature <i>Dr. for J.J.</i>	
Floor Area(sq. ft.)		Residential/Commercial Commercial			
Job Description EXPAND RESTAURANT INTO ADJOINING TENANT SPACE INCL. REMOVE SECTION OF WALL/UPGRADE M E P					
<p align="center">DECLARATION</p> <p>I certify that I have read this application/permit and state that the information on all pages of this document is correct. I agree to comply with all City and County ordinances and State laws relating to building construction, and hereby authorize representatives of this City and County to enter upon the above mentioned property for inspection purposes.</p>					
<input checked="" type="checkbox"/> Applicant's Signature <i>John Truong</i>		Date <i>11/29/12</i>			
Print Name <i>John Truong</i>					

**Permit Type:
BLDG/MECH/PLUMB/ELEC**



**CITY OF GARDEN GROVE
BUILDING SERVICES**

**13916 BROOKHURST
ST**

**PERMIT#:12-2396
ISSUED:11/29/12**

**General Info : 714-741-5307
Inspection Requests : 714-741-5332**

	F E E S		
	Description	Quantity	Amount
	Plan Check Fee - Disabled Access (Commercial)	1	\$66.04
	Plan Check Fee		\$660.35
	Ventilation/Ehaust, Vent fan connected to single duct	2	\$44.00
	Commercial range hood (including duct and fan)	3	\$30.00
	Ducts	1	\$12.00
	Gas System	1	\$18.50
	Industrial waste pre-treatment interceptor, sand trap, receptor	1	\$95.00
	Water Piping	1	\$30.00
	Building Sewer	1	\$30.00
	Urinal	1	\$9.50
	Dishwasher	1	\$9.50
	Floor drain	8	\$76.00
	Floor sink	8	\$76.00
	Water Heater	2	\$60.00
	Lavatory	2	\$19.00
	Water closet, Bidet	2	\$19.00
	Receptical, switch, outlet, and fixture	87	\$70.25
	Building Permit Document Retention Fee	1	\$5.00
	Building Technology Fee	1	\$10.00
	Plan Retention	15	\$60.00
	BSASRF State Fee		\$4.00
	Issuance Fee	1	\$35.00
	Building Permit Fee		\$996.00
	One-Stop Permit Center Surcharge		\$19.92
	Cultural Arts Fee, Valuation		\$59.00
	General Plan Update Fee, Valuation		\$118.00
	TOTAL		\$2,632.06

This is a building permit when properly filled out, signed and validated, and is subject to expiration if work thereunder is suspended for 180 days.

**Permit Type:
BLDG/MECH/PLUMB/ELEC**



**CITY OF GARDEN GROVE
BUILDING SERVICES**

**13916 BROOKHURST
ST**

**PERMIT#:11-2433
ISSUED:11/3/11**

General Info : 714-741-5307
Inspection Requests : 714-741-5332

Owner CHOE,WINSTON TRUST			Telephone	Zip 92843	Building Address 13916 BROOKHURST ST																														
Address 13916 BROOKHURST ST		City Garden Grove	State CA		Suite/Unit/Building																														
Applicant UNITED FIRE & SAFETY CO.			Telephone 951-675-0220	Zip 92503	TYPE Fire Sprinklers		ISSUED BY Yoav Shernock																												
Address 12305 DOHERTY ST		City RIVERSIDE	State CA		Inspector Dist. N16	Parcel Number 09934413	LOT TRACT																												
State Licence 621096 C16	Expires N/A	City Licence	Expires		Valuation \$1,800.00																														
Contractor UNITED FIRE & SAFETY CO.			Telephone 951-675-0220	Zip 92503	Final																														
Address 12305 DOHERTY ST		City RIVERSIDE	State CA		Inspector's Signature _____ Date _____																														
State Licence 621096 C16	Expires N/A	City Licence	Expires		<table border="1" style="width:100%; border-collapse: collapse;"> <tr> <td rowspan="8" style="writing-mode: vertical-rl; text-orientation: mixed; font-weight: bold; font-size: 2em;">F E E S</td> <td>Description</td> <td>Quantity</td> <td>Amount</td> </tr> <tr> <td>Cultural Arts Fee, Valuation</td> <td></td> <td>\$1.83</td> </tr> <tr> <td>General Plan Update Fee, Valuation</td> <td></td> <td>\$3.67</td> </tr> <tr> <td>BSASRF State Fee</td> <td></td> <td>\$1.00</td> </tr> <tr> <td>Issuance Fee</td> <td>1</td> <td>\$35.00</td> </tr> <tr> <td>One-Stop Permit Center Surcharge</td> <td></td> <td>\$1.58</td> </tr> <tr> <td>Building Permit Fee</td> <td></td> <td>\$79.00</td> </tr> <tr> <td>Plan Check Fee</td> <td></td> <td>\$60.00</td> </tr> <tr> <td>TOTAL</td> <td></td> <td>\$182.08</td> </tr> </table>			F E E S	Description	Quantity	Amount	Cultural Arts Fee, Valuation		\$1.83	General Plan Update Fee, Valuation		\$3.67	BSASRF State Fee		\$1.00	Issuance Fee	1	\$35.00	One-Stop Permit Center Surcharge		\$1.58	Building Permit Fee		\$79.00	Plan Check Fee		\$60.00	TOTAL		\$182.08
F E E S	Description	Quantity	Amount																																
	Cultural Arts Fee, Valuation		\$1.83																																
	General Plan Update Fee, Valuation		\$3.67																																
	BSASRF State Fee		\$1.00																																
	Issuance Fee	1	\$35.00																																
	One-Stop Permit Center Surcharge		\$1.58																																
	Building Permit Fee		\$79.00																																
	Plan Check Fee		\$60.00																																
TOTAL		\$182.08																																	
Floor Area(sq. ft.)		Residential/Commercial Commercial																																	
Job Description ul300 upgrade to existing kitchen hood system																																			
DECLARATION																																			
I certify that I have read this application/permit and state that the information on all pages of this document is correct. I agree to comply with all City and County ordinances and State laws relating to building construction, and hereby authorize representatives of this City and County to enter upon the above mentioned property for inspection purposes.																																			
<input checked="" type="checkbox"/>	Applicant's Signature <i>[Signature]</i>		Date 11/03/11																																
	Print Name JOHN TAN																																		

This is a building permit when properly filled out, signed and validated, and is subject to expiration if work thereunder is suspended for 180 days.

EXPIRED

Permit Type: BLDG

ORIGINAL



CITY OF GARDEN GROVE BUILDING SERVICES

**13916 BROOKHURST
ST**

**PERMIT#:11-2145
ISSUED:9/28/11**

General Info : 714-741-5307
Inspection Requests : 714-741-5332

Owner CHOE, WINSTON TRUST		Telephone	Zip 92843	Building Address 13916 BROOKHURST ST	
Address 13916 BROOKHURST ST		City Garden Grove	State CA	Suite/Unit/Building UNIT # A	
Applicant T & K CONSTRUCTION CO		Telephone 714-454-4570	Zip 92708	TYPE Miscellaneous	
Address 17660 NEWHOPE #B		City FOUNTAIN VALLEY	State	ISSUED BY Don Lucas	
State Licence 793124,B	Expires N/A	City Licence	Expires	Inspector Dist. N16	Parcel Number 09934413
Contractor T & K CONSTRUCTION CO		Telephone 714-454-4570	Zip 92708	LOT	TRACT
Address 17660 NEWHOPE #B		City FOUNTAIN VALLEY	State	Valuation \$20,000.00	
State Licence 793124,B	Expires N/A	City Licence	Expires	Final Inspector's Signature <i>R Price</i> Date <i>4/2/12</i>	
Floor Area(sq. ft.)	Residential/Commercial Commercial				
Job Description NEW KITCHEN HOOD, RANGE, GAS FRY & GREASE TRAP.					
<p style="text-align: center;">DECLARATION</p> <p>I certify that I have read this application/permit and state that the information on all pages of this document is correct. I agree to comply with all City and County ordinances and State laws relating to building construction, and hereby authorize representatives of this City and County to enter upon the above mentioned property for inspection purposes.</p>					
<p>X Applicant's Signature <i>Tong Nguyen</i> Print Name <i>TONG NGUYEN</i> Date <i>9/28/11</i></p>					
F E E S		Description		Quantity	Amount
		Commercial range hood (including duct and fan)		1	\$10.00
		Gas System		2	\$18.50
		Industrial waste pre-treatment interceptor, sand trap, receptor		1	\$95.00
		Receptical, switch, outlet, and fixture		5	\$5.00
		Water Plan Check		0.5	\$30.00
		General Plan Update Fee, Valuation			\$24.67
		Cultural Arts Fee, Valuation			\$12.33
		Plan Check Fee - Disabled Access (Commercial)		1	\$21.91
		Plan Check Fee			\$219.12
		BSASRF State Fee			\$1.00
		Plumbing Plan Check Fee		1	\$96.48
		Mechanical Plan Check Fee		1	\$80.00
		Issuance Fee		1	\$35.00
		One-Stop Permit Center Surcharge			\$6.61
Building Permit Fee			\$330.50		
TOTAL			\$986.12		

This is a building permit when properly filled out, signed and validated, and is subject to expiration if work thereunder is suspended for 180 days.

**Permit Type:
MECH/PLUMB/ELEC/BLDG**



General Information: 714-741-5307

CITY OF GARDEN GROVE - DEVELOPMENT SERVICES DEPARTMENT

Inspection Requests: 714-741-5332

PERMIT (PAGE 2 of 2)

PROJECT/SITE/BUILDING DESCRIPTION

PROPOSED WORK:

JOB Address : 13916 BROOKHURST ST
 Suite : B
 PERMIT NO. : 93509
 Permit Type :
 Type : E

ELECTRICAL FOR ILLUM WALL SIGN

Owner : TRUST CHOE, WINSTON
 Applicant : HOA
 Phone : 271-7118

Contractor : SIGNEX
 Address : 10852 FORBES AVE #C2
 CityStZip : GARDEN GROVE, CA 92843
 Phone : 714-265-3710

FEES

Insp Dist : SE
 Date : 02/14/08
 Parcel No : 09934413

942 22130	GENERAL PLAN	1	2.00
080 32550	CULTURAL ARTS	1	1.00
111 32401	Issuance	1	35.00
111 32412	Light&Marquee (1 bra	1	50.00
TOTAL			88.00

APPROVAL DATE INSPECTOR

Underground _____
 Conduit _____
 Wiring - Rough _____
 Heater _____
 Fixtures & Trim _____
 Motors _____
 Ufer _____
 Service _____

EXPIRED

FINAL 5-6-09 T.H
 Utility Notified _____

AUTHORIZATION

Issued By: joannec Date _____

DECLARATION

I certify that I have read this application/permit and state that the information on all pages of this document is correct. I agree to comply with all City and County ordinances and State laws relating to building construction, and hereby authorize representatives of this City and County to enter upon the above mentioned property for inspection purposes.

Applicant's Signature HOA

Print Name HOA Date 2/15/08

***** VALIDATION *****
 PAID ON 14 Feb 2008 AT 15:50
 RECEIVED BY RONP 198.245.206.215/2 TRANS# 146
 AMOUNT PAID \$274.66 BY CHECK#1035
 TOTAL PAID = \$274.66



General Information: 714-741-5307

CITY OF GARDEN GROVE - DEVELOPMENT SERVICES DEPARTMENT

Inspection Requests: 714-741-5332

PERMIT (PAGE 2 of 2)

PROJECT/SITE/BUILDING-DESCRIPTION

JOB Address : 13916 BROOKHURST ST
 Suite : B
 PERMIT NO. : 93508
 Permit Type : SIGN
 Type : B11
 SIGNS
 Owner : TRUST CHOE, WINSTON
 Applicant : HOA
 Phone : 262-3710

Contractor : SIGNEX
 Address : 10852 FORBES AVE #C2
 CityStZip : GARDEN GROVE, CA 92843
 Phone : 714-265-3710

Insp Dist : SB
 Date : 02/14/08
 Parcel No : 09934413

Value : 8200
 Floor area : 0

PROPOSED WORK:

O28 - SIGNS
 1 ILLUM WALL SIGN

FEES

111 32509 PLAN CHECK 65% (\$42.0	1	53.30
111 32410 Permit	1	82.00
111 32401 issuance	1	35.00
942 22130 General Plan	1	10.96
080 32550 Cultural Arts	1	5.40
TOTAL		186.66

APPROVAL DATE INSPECTOR

Pre Inspect _____
 Foundation _____
 Concrete Floor _____
 Reinforcing _____
 Masonry _____
 Roof Shtg _____
 Rough Frame _____
 Insul / Energy _____
 Drywall _____
 Lath _____
 Plas. Brown Ct. _____
 Landscaping _____
 Pre Gunite _____
 Pre Deck _____
 Pre Plaster _____

Planning Final _____
 Bldg Final _____
 Utility Notified _____

EXPIRED

S-6-09 T.H

AUTHORIZATION

Issued By: joannec _____ Date _____

DECLARATION

I certify that I have read this application/permit and state that the information on all pages of this document is correct. I agree to comply with all City and County ordinances and State laws relating to building construction, and hereby authorize representatives of this City and County to enter upon the above mentioned property for inspection purposes.

Applicant's Signature HOA

Print Name HOA Date 2/15/08

***** VALIDATION *****
 PAID ON 14 Feb 2008 AT 15:50
 RECEIVED BY ROMP 198.245.206.215/2 TRANS# 146
 AMOUNT PAID \$274.66 BY CHECK#1035
 TOTAL PAID = \$274.66



**CITY OF GARDEN GROVE
BUILDING SERVICES**

✓ **13916 BROOKHURST
ST**

**PERMIT#:09-0985
ISSUED:8/27/09**

General Info : 714-741-5307
Inspection Requests : 714-741-5332

Owner CHOE, WINSTON TRUST			Telephone	Zip	Building Address 13916 BROOKHURST ST																						
Address 13916 BROOKHURST ST			City Garden Grove	State CA	Suite/Unit/Building E																						
Applicant CHRIS DO			Telephone 714-422-4721	Zip 92840	TYPE		ISSUED BY Yoav Shernock																				
Address 11621 STEPHANIE LN			City GARDEN GROVE	State CA	Inspector Dist.	Parcel Number 09934413	LOT TRACT																				
State Licence 894391 B	Expires N/A	City Licence	Expires		Valuation			\$0.00																			
Contractor CHRIS DO			Telephone 714-422-4721	Zip 92840	Final																						
Address 11621 STEPHANIE LN			City GARDEN GROVE	State CA	Inspector's Signature <i>[Signature]</i>																						
State Licence 894391 B	Expires N/A	City Licence	Expires		Date <u>8/25/09</u>																						
Floor Area(sq. ft.)	Residential/Commercial Commercial																										
Job Description MECH FOR T.I. FOR BOBA RESTAURANT																											
DECLARATION																											
I certify that I have read this application/permit and state that the information on all pages of this document is correct. I agree to comply with all City and County ordinances and State laws relating to building construction, and hereby authorize representatives of this City and County to enter upon the above mentioned property for inspection purposes.																											
<input checked="" type="checkbox"/>	Applicant's Signature <i>[Signature]</i>			Date <u>8/27/09</u>																							
<table border="1" style="width:100%; border-collapse: collapse;"> <tr> <td rowspan="5" style="text-align: center; vertical-align: middle;">F E E S</td> <td>Description</td> <td>Quantity</td> <td>Amount</td> </tr> <tr> <td>Issuance Fee</td> <td>1</td> <td>\$35.00</td> </tr> <tr> <td>Ducts</td> <td>1</td> <td>\$12.00</td> </tr> <tr> <td>Commercial range hood (including duct and fan)</td> <td>2</td> <td>\$20.00</td> </tr> <tr> <td>Fire Damper</td> <td>1</td> <td>\$9.50</td> </tr> <tr> <td colspan="2">TOTAL</td> <td></td> <td>\$76.50</td> </tr> </table>								F E E S	Description	Quantity	Amount	Issuance Fee	1	\$35.00	Ducts	1	\$12.00	Commercial range hood (including duct and fan)	2	\$20.00	Fire Damper	1	\$9.50	TOTAL			\$76.50
F E E S	Description	Quantity	Amount																								
	Issuance Fee	1	\$35.00																								
	Ducts	1	\$12.00																								
	Commercial range hood (including duct and fan)	2	\$20.00																								
	Fire Damper	1	\$9.50																								
TOTAL			\$76.50																								

This is a building permit when properly filled out, signed and validated, and is subject to expiration if work thereunder is suspended for 180 days.

Permit Type: MECH

ORIGINAL



**CITY OF GARDEN GROVE
BUILDING SERVICES**

✓ **13916 BROOKHURST
ST**

**PERMIT#:09-0982
ISSUED:8/27/09**

General Info : 714-741-5307
Inspection Requests : 714-741-5332

Owner			Telephone	Zip	Building Address			
CHOE, WINSTON TRUST				92843	13916 BROOKHURST ST			
Address		City	State	Suite/Unit/Building				
13916 BROOKHURST ST		Garden Grove	CA	E				
Applicant			Telephone	Zip	TYPE		ISSUED BY	
CHRIS DO			714-422-4721	92840	Tenant Improvement		Don Lucas	
Address		City	State	Inspector Dist.		Parcel Number	LOT	TRACT
11621 STEPHANIE LN		GARDEN GROVE	CA			09934413		
State Licence	Expires	City Licence	Expires					
894391 B	N/A							
Contractor			Telephone	Zip	Valuation			
CHRIS DO			714-422-4721	92840	\$187,095.60			
Address		City	State	Final				
11621 STEPHANIE LN		GARDEN GROVE	CA	Inspector's Signature <i>[Signature]</i>				
State Licence	Expires	City Licence	Expires	Date <u>11 25 09</u>				
894391 B	N/A							
Floor Area(sq. ft.)		Residential/Commercial						
		Commercial						
Job Description								
TI for Boba restaraunt								
DECLARATION								
I certify that I have read this application/permit and state that the information on all pages of this document is correct. I agree to comply with all City and County ordinances and State laws relating to building construction, and hereby authorize representatives of this City and County to enter upon the above mentioned property for inspection purposes.								
X Applicant's Signature <i>[Signature]</i>								
Print Name <i>[Signature]</i>			Date <u>8/28/09</u>					

Permit Type: BLDG

ORIGINAL



**CITY OF GARDEN GROVE
BUILDING SERVICES**

**13916 BROOKHURST
ST**

PERMIT#:09-0982

ISSUED:8/27/09

General Info : 714-741-5307

Inspection Requests : 714-741-5332

	F E E S		
	Description	Quantity	Amount
	Building Permit Fee		\$1,539.20
	Issuance Fee	1	\$35.00
	Fire Plan Check Fee - Commercial TI under 6000 sqft	1	\$55.00
	Planning Plan Check Fee - Tenant Improvement	1	\$50.00
	Ad-hoc	1	\$80.00
	Engineering Plan Check - Tenant Improvement	1	\$55.00
	Water Plan Check - Tenant Improvements	1	\$50.00
	Ad-hoc	1	\$80.00
	BSASRF State Fee		\$8.00
	Restaurants - Type V - N	1308	\$112,095.60
	Ad-hoc	1	\$80.00
	General Plan Update Fee, Valuation		\$220.67
	Cultural Arts Fee, Valuation		\$110.33
	Plan Check Fee		\$1,020.49
	One-Stop Permit Center Surcharge		\$30.78
	Plan Check Fee - Energy Conservation (Commercial)	1	\$102.05
	Plan Check Fee - Disabled Access (Commercial)	1	\$102.05
	SMI (Commercial)	1	\$39.29
	TOTAL		\$3,657.86

This is a building permit when properly filled out, signed and validated, and is subject to expiration if work thereunder is suspended for 180 days.

Permit Type: BLDG

ORIGINAL



**CITY OF GARDEN GROVE
BUILDING SERVICES**

**13916 BROOKHURST
ST**

PERMIT#:09-0982

ISSUED:8/27/09

General Info : 714-741-5307

Inspection Requests : 714-741-5332

	F E E S		
	Description	Quantity	Amount
	Building Permit Fee		\$1,539.20
	Issuance Fee	1	\$35.00
	Fire Plan Check Fee - Commercial TI under 6000 sqft	1	\$55.00
	Planning Plan Check Fee - Tenant Improvement	1	\$50.00
	Ad-hoc	1	\$80.00
	Engineering Plan Check - Tenant Improvement	1	\$55.00
	Water Plan Check - Tenant Improvements	1	\$50.00
	Ad-hoc	1	\$80.00
	BSASRF State Fee		\$8.00
	Restaurants - Type V - N	1308	\$112,095.60
	Ad-hoc	1	\$80.00
	General Plan Update Fee, Valuation		\$220.67
	Cultural Arts Fee, Valuation		\$110.33
	Plan Check Fee		\$1,020.49
	One-Stop Permit Center Surcharge		\$30.78
	Plan Check Fee - Energy Conservation (Commercial)	1	\$102.05
	Plan Check Fee - Disabled Access (Commercial)	1	\$102.05
	SMI (Commercial)	1	\$39.29
	TOTAL		\$3,657.86

This is a building permit when properly filled out, signed and validated, and is subject to expiration if work thereunder is suspended for 180 days.

Permit Type: BLDG



**CITY OF GARDEN GROVE
BUILDING SERVICES**

**13916 BROOKHURST
ST**

**PERMIT#:09-0984
ISSUED:8/27/09**

General Info : 714-741-5307
Inspection Requests : 714-741-5332

Owner CHOE,WINSTON TRUST			Telephone		Zip 92843	Building Address 13916 BROOKHURST ST		
Address 13916 BROOKHURST ST			City Garden Grove		State CA	Suite/Unit/Building E		
Applicant CHRIS DO			Telephone 714-422-4721		Zip 92840	TYPE		ISSUED BY Yoav Shernock
Address 11621 STEPHANIE LN			City GARDEN GROVE		State CA	Inspector Dist.	Parcel Number 09934413	LOT TRACT
State Licence 894391 B		Expires N/A		City Licence		Expires		
Contractor CHRIS DO			Telephone 714-422-4721		Zip 92840	Valuation \$0.00		
Address 11621 STEPHANIE LN			City GARDEN GROVE		State CA	Final Inspector's Signature <i>M. Shernock</i> Date <i>11 25 09</i>		
State Licence 894391 B		Expires N/A		City Licence		Expires		
Floor Area(sq. ft.)		Residential/Commercial Commercial						
Job Description PLBG FOR T.I. FOR BOBA RESTAURANT								
DECLARATION								
I certify that I have read this application/permit and state that the information on all pages of this document is correct. I agree to comply with all City and County ordinances and State laws relating to building construction, and hereby authorize representatives of this City and County to enter upon the above mentioned property for inspection purposes.								
<input checked="" type="checkbox"/> Applicant's Signature <i>Tam Truay</i>		Date <i>8/27/09</i>						
Print Name <i>Tam Truay</i>								
F E E S	Description		Quantity		Amount			
	Issuance Fee		1		\$35.00			
	Water closet, Bidet		1		\$9.50			
	Lavatory		1		\$9.50			
	Kitchen Sink		7		\$66.50			
	Water Heater		1		\$30.00			
	Floor sink		6		\$57.00			
	Floor drain		2		\$19.00			
	Gas System		3		\$18.50			
	Industrial waste pre-treatment interceptor		1		\$95.00			
	Ad-hoc		1		\$15.00			
	TOTAL				\$355.00			

This is a building permit when properly filled out, signed and validated, and is subject to expiration if work thereunder is suspended for 180 days.

Permit Type: PLUMB

ORIGINAL



**CITY OF GARDEN GROVE
BUILDING SERVICES**

**✓13916 BROOKHURST
ST**

**PERMIT#:09-1355
ISSUED:10/6/09**

General Info : 714-741-5307
Inspection Requests : 714-741-5332

Owner CHOE, WINSTON TRUST			Telephone		Zip 92843	Building Address 13916 BROOKHURST ST																																								
Address 13916 BROOKHURST ST		City Garden Grove		State CA		Suite/Unit/Building																																								
Applicant ALPHA SYSTEMS FIRE PROTECTION INC			Telephone 800-540-7605		Zip 91333	TYPE Fire Sprinklers		ISSUED BY Joanne Chung																																						
Address 19900 MAYALL ST		City CHATSWORTH		State CA		Inspector Dist.	Parcel Number 09934413	LOT	TRACT																																					
State Licence 687305 C16		Expires N/A		City Licence		Expires		Valuation \$2,000.00																																						
Contractor ALPHA SYSTEMS FIRE PROTECTION INC			Telephone 800-540-7605		Zip 91333	Final Inspector's Signature <u>SNBolt's</u> Date <u>11/19/09</u>																																								
Address 19900 MAYALL ST		City CHATSWORTH		State CA		<table border="1" style="width:100%; border-collapse: collapse;"> <tr> <td rowspan="10" style="text-align: center; vertical-align: middle; font-size: 2em;">F E E S</td> <td colspan="2">Description</td> <td>Quantity</td> <td>Amount</td> </tr> <tr> <td colspan="2">General Plan Update Fee, Valuation</td> <td></td> <td>\$3.67</td> </tr> <tr> <td colspan="2">Cultural Arts Fee, Valuation</td> <td></td> <td>\$1.83</td> </tr> <tr> <td colspan="2">Plan Check Fee</td> <td></td> <td>\$60.00</td> </tr> <tr> <td colspan="2">Building Permit Fee</td> <td></td> <td>\$85.00</td> </tr> <tr> <td colspan="2">One-Stop Permit Center Surcharge</td> <td></td> <td>\$1.70</td> </tr> <tr> <td colspan="2">Issuance Fee</td> <td>1</td> <td>\$35.00</td> </tr> <tr> <td colspan="2">BSASRF State Fee</td> <td></td> <td>\$1.00</td> </tr> <tr> <td colspan="2">TOTAL</td> <td></td> <td>\$188.20</td> </tr> </table>				F E E S	Description		Quantity	Amount	General Plan Update Fee, Valuation			\$3.67	Cultural Arts Fee, Valuation			\$1.83	Plan Check Fee			\$60.00	Building Permit Fee			\$85.00	One-Stop Permit Center Surcharge			\$1.70	Issuance Fee		1	\$35.00	BSASRF State Fee			\$1.00	TOTAL			\$188.20
F E E S	Description		Quantity	Amount																																										
	General Plan Update Fee, Valuation			\$3.67																																										
	Cultural Arts Fee, Valuation			\$1.83																																										
	Plan Check Fee			\$60.00																																										
	Building Permit Fee			\$85.00																																										
	One-Stop Permit Center Surcharge			\$1.70																																										
	Issuance Fee		1	\$35.00																																										
	BSASRF State Fee			\$1.00																																										
	TOTAL			\$188.20																																										
	State Licence 687305 C16		Expires N/A		City Licence		Expires																																							
Floor Area(sq. ft.)		Residential/Commercial Commercial																																												
Job Description INSTALL HOOD FIRE SUPPRESSION UL300 SYSTEM																																														
DECLARATION																																														
I certify that I have read this application/permit and state that the information on all pages of this document is correct. I agree to comply with all City and County ordinances and State laws relating to building construction, and hereby authorize representatives of this City and County to enter upon the above mentioned property for inspection purposes.																																														
X Applicant's Signature <u>Hal Sneider</u>																																														
Print Name <u>HAL SNEIDER</u>				Date <u>Oct 6, 2009</u>																																										

This is a building permit when properly filled out, signed and validated, and is subject to expiration if work thereunder is suspended for 180 days.

Permit Type: BLDG

ORIGINAL

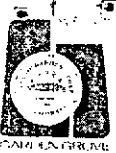

**CITY OF GARDEN GROVE
BUILDING SERVICES**

**✓13916 BROOKHURST
ST**

**PERMIT#:09-0983
ISSUED:8/27/09**

General Info : 714-741-5307
Inspection Requests : 714-741-5332

Owner CHOE, WINSTON TRUST		Telephone	Zip	Building Address 13916 BROOKHURST ST																					
Address 13916 BROOKHURST ST		City Garden Grove	State CA	Suite/Unit/Building E																					
Applicant CHRIS DO		Telephone 714-422-4721	Zip 92840	TYPE		ISSUED BY Yoav Shernock																			
Address 11621 STEPHANIE LN		City GARDEN GROVE	State CA	Inspector Dist.	Parcel Number 09934413	LOT	TRACT																		
State Licence 894391 B	Expires N/A	City Licence	Expires	Valuation \$0.00																					
Contractor CHRIS DO		Telephone 714-422-4721	Zip 92840	Final Inspector's Signature <u>T.H</u> Date <u>11-10-09</u>																					
Address 11621 STEPHANIE LN		City GARDEN GROVE	State CA	<table border="1"> <thead> <tr> <th>Description</th> <th>Quantity</th> <th>Amount</th> </tr> </thead> <tbody> <tr> <td>Issuance Fee</td> <td>1</td> <td>\$35.00</td> </tr> <tr> <td>Receptical, switch, lighting outlet and fixture</td> <td>70</td> <td>\$57.50</td> </tr> <tr> <td>Time Clock</td> <td>2</td> <td>\$9.00</td> </tr> <tr> <td>Switchboard, Motor Control Center, etc.</td> <td>5</td> <td>\$160.00</td> </tr> <tr> <td>S TOTAL</td> <td></td> <td>\$261.50</td> </tr> </tbody> </table>				Description	Quantity	Amount	Issuance Fee	1	\$35.00	Receptical, switch, lighting outlet and fixture	70	\$57.50	Time Clock	2	\$9.00	Switchboard, Motor Control Center, etc.	5	\$160.00	S TOTAL		\$261.50
Description	Quantity	Amount																							
Issuance Fee	1	\$35.00																							
Receptical, switch, lighting outlet and fixture	70	\$57.50																							
Time Clock	2	\$9.00																							
Switchboard, Motor Control Center, etc.	5	\$160.00																							
S TOTAL		\$261.50																							
State Licence 894391 B	Expires N/A	City Licence	Expires																						
Floor Area(sq. ft.)	Residential/Commercial Commercial			<table border="1"> <thead> <tr> <th>Description</th> <th>Quantity</th> <th>Amount</th> </tr> </thead> <tbody> <tr> <td>Issuance Fee</td> <td>1</td> <td>\$35.00</td> </tr> <tr> <td>Receptical, switch, lighting outlet and fixture</td> <td>70</td> <td>\$57.50</td> </tr> <tr> <td>Time Clock</td> <td>2</td> <td>\$9.00</td> </tr> <tr> <td>Switchboard, Motor Control Center, etc.</td> <td>5</td> <td>\$160.00</td> </tr> <tr> <td>S TOTAL</td> <td></td> <td>\$261.50</td> </tr> </tbody> </table>				Description	Quantity	Amount	Issuance Fee	1	\$35.00	Receptical, switch, lighting outlet and fixture	70	\$57.50	Time Clock	2	\$9.00	Switchboard, Motor Control Center, etc.	5	\$160.00	S TOTAL		\$261.50
Description	Quantity	Amount																							
Issuance Fee	1	\$35.00																							
Receptical, switch, lighting outlet and fixture	70	\$57.50																							
Time Clock	2	\$9.00																							
Switchboard, Motor Control Center, etc.	5	\$160.00																							
S TOTAL		\$261.50																							
Job Description ELEC FOR T.I. FOR BOBA RESTAURANT				<table border="1"> <thead> <tr> <th>Description</th> <th>Quantity</th> <th>Amount</th> </tr> </thead> <tbody> <tr> <td>Issuance Fee</td> <td>1</td> <td>\$35.00</td> </tr> <tr> <td>Receptical, switch, lighting outlet and fixture</td> <td>70</td> <td>\$57.50</td> </tr> <tr> <td>Time Clock</td> <td>2</td> <td>\$9.00</td> </tr> <tr> <td>Switchboard, Motor Control Center, etc.</td> <td>5</td> <td>\$160.00</td> </tr> <tr> <td>S TOTAL</td> <td></td> <td>\$261.50</td> </tr> </tbody> </table>				Description	Quantity	Amount	Issuance Fee	1	\$35.00	Receptical, switch, lighting outlet and fixture	70	\$57.50	Time Clock	2	\$9.00	Switchboard, Motor Control Center, etc.	5	\$160.00	S TOTAL		\$261.50
Description	Quantity	Amount																							
Issuance Fee	1	\$35.00																							
Receptical, switch, lighting outlet and fixture	70	\$57.50																							
Time Clock	2	\$9.00																							
Switchboard, Motor Control Center, etc.	5	\$160.00																							
S TOTAL		\$261.50																							
<p align="center">DECLARATION</p> <p>I certify that I have read this application/permit and state that the information on all pages of this document is correct. I agree to comply with all City and County ordinances and State laws relating to building construction, and hereby authorize representatives of this City and County to enter upon the above mentioned property for inspection purposes.</p>																									
X Applicant's Signature <u>[Signature]</u>		Print Name <u>Tom Strung</u>		Date <u>8/27/09</u>																					

This is a building permit when properly filled out, signed and validated, and is subject to expiration if work thereunder is suspended for 180 days.

WIRING STILL INCOMPLETE
NEAR ROOF ACCESS - PROTECT
WIRING NEAR ACCESSES +
ABOVE FIREZEL - MUST BE ACCESSIBLE
10-21-09 T.H

ORIGINAL

Permit Type: ELEC



General Information: 714-741-5307

CITY OF GARDEN GROVE - DEVELOPMENT SERVICES DEPARTMENT

Inspection Requests: 714-741-5332

PERMIT (PAGE 2 of 2)

PROJECT/SITE/BUILDING DESCRIPTION

PROPOSED WORK:

JOB Address : 13916 BROOKHURST ST
 Suite :
 PERMIT NO. : 96741
 Permit Type :
 Type : E

SUPPLIMENTAL TO PERMIT #96182, A/C UNIT.

Owner : TRUST CHOE, WINSTON
 Applicant : KY NGUYEN
 Phone : 714-875-6877

Contractor : NDK CONSTRUCTION
 Address : 13121 NEWHOPE
 CityStZip : GARDEN GROVE, CA 92843
 Phone : 537-0873

FEEES

Insp Dist : ZE
 Date : 12/22/08
 Parcel No : 09934413

111 32412 Pwr.App. 1hp, 1kw, 1kv	1	9.50
111 32401 SUPPLEMENTAL PERMIT/	1	15.00
TOTAL		24.50

APPROVAL DATE INSPECTOR

- Underground _____
- Conduit _____
- Wiring - Rough _____
- Heater _____
- Fixtures & Trim _____
- Motors _____
- Ufer _____
- Service _____

FINAL 12-23-08 Per Computer.

Utility Notified _____

AUTHORIZATION

Issued By: jimc Date _____

DECLARATION

I certify that I have read this application/permit and state that the information on all pages of this document is correct. I agree to comply with all City and County ordinances and State laws relating to building construction, and hereby authorize representatives of this City and County to enter upon the above mentioned property for inspection purposes.

Applicant's Signature Ky Nguyen
 Print Name Ky Nguyen Date 12-22-08

***** VALIDATION *****
 PAID ON 22 Dec 2008 AT 14:52
 RECEIVED BY EDWARDM 198.245.206.215 TRANS# 10907
 AMOUNT PAID \$24.50 BY CHECK
 TOTAL PAID = \$24.50



General Information: 714-741-5307

CITY OF GARDEN GROVE - DEVELOPMENT SERVICES DEPARTMENT

Inspection Requests: 714-741-5332

PERMIT (PAGE 2 of 2)

PROJECT/SITE/BUILDING DESCRIPTION

JOB Address : 13916 BROOKHURST ST
 Suite : A
 PERMIT NO. : 96181
 Permit Type : BUILDING
 Type : B7
 ALTERATIONS TO OTHER BUILDINGS
 Owner : TRUST CHOE, WINSTON
 Applicant : KY NGUYEN
 Phone : 875-6877

Contractor : NDK CONSTRUCTION
 Address : 13121 NEWHOPE
 CityStZip : GARDEN GROVE, CA 92843
 Phone : 537-0873

Insp Dist : ZB
 Date : 10/22/08
 Parcel No : 09934413

Value : 20000
 Floor area : 0

PROPOSED WORK:

O43 - T.I. COMMERCIAL

NEW COFFEE SHOP INCLUDING NEW PLUMBING PLANET COFFEE

FEES

111 32410 Permit	1	337.11
111 32401 issuance	1	35.00
942 22130 General Plan	1	24.79
080 32550 Cultural Arts	1	12.21
TOTAL		409.11

APPROVAL DATE INSPECTOR

Pre Inspect _____
 Foundation _____
 Concrete Floor _____
 Reinforcing _____
 Masonry _____
 Roof Shtg _____
 Rough Frame _____
 Insul / Energy _____
 Drywall 11/3/08 TEH
 Lath _____
 Plas. Brown Ct. _____
 Landscaping _____
 Pre Gunite _____
 Pre Deck _____
 Pre Plaster _____

Planning Final _____

Bldg Final 1/7/09 ASmarc

Utility Notified _____

AUTHORIZATION

Issued By: joannec Date _____

DECLARATION

I certify that I have read this application/permit and state that the information on all pages of this document is correct. I agree to comply with all City and County ordinances and State laws relating to building construction, and hereby authorize representatives of this City and County to enter upon the above mentioned property for inspection purposes.

Applicant's Signature Giang Nam

Print Name GIANG NGUYEN Date 10-22-08

***** VALIDATION *****
 PAID ON 22 Oct 2008 AT 15:13
 RECEIVED BY EDWARD M 198.245.206.215 TRANS# 917
 AMOUNT PAID \$6171.91 BY CHECK
 TOTAL PAID = \$409.11

CITY OF GARDEN GROVE - COMMUNITY DEVELOPMENT DEPARTMENT

Plot Plan Form

Planning Action: Approved	Zone: C-2	Coverage:
Approved By: [Signature]	Date: 10/16/08	Increase:
Remarks:		

Job Address: 13916 A BROOKHURST	Permit No.:
Assessor Parcel No.:	Tract & Lot #:
Occupancy: A-2	Const. Type: B
Value: 20,000.00	
<input type="checkbox"/> New <input type="checkbox"/> Alter <input type="checkbox"/> Add <input type="checkbox"/> Repair <input type="checkbox"/> Demo	

Job Description:

COFFEE SHOP (1,610 SF)

*** Only two (2) computers.**

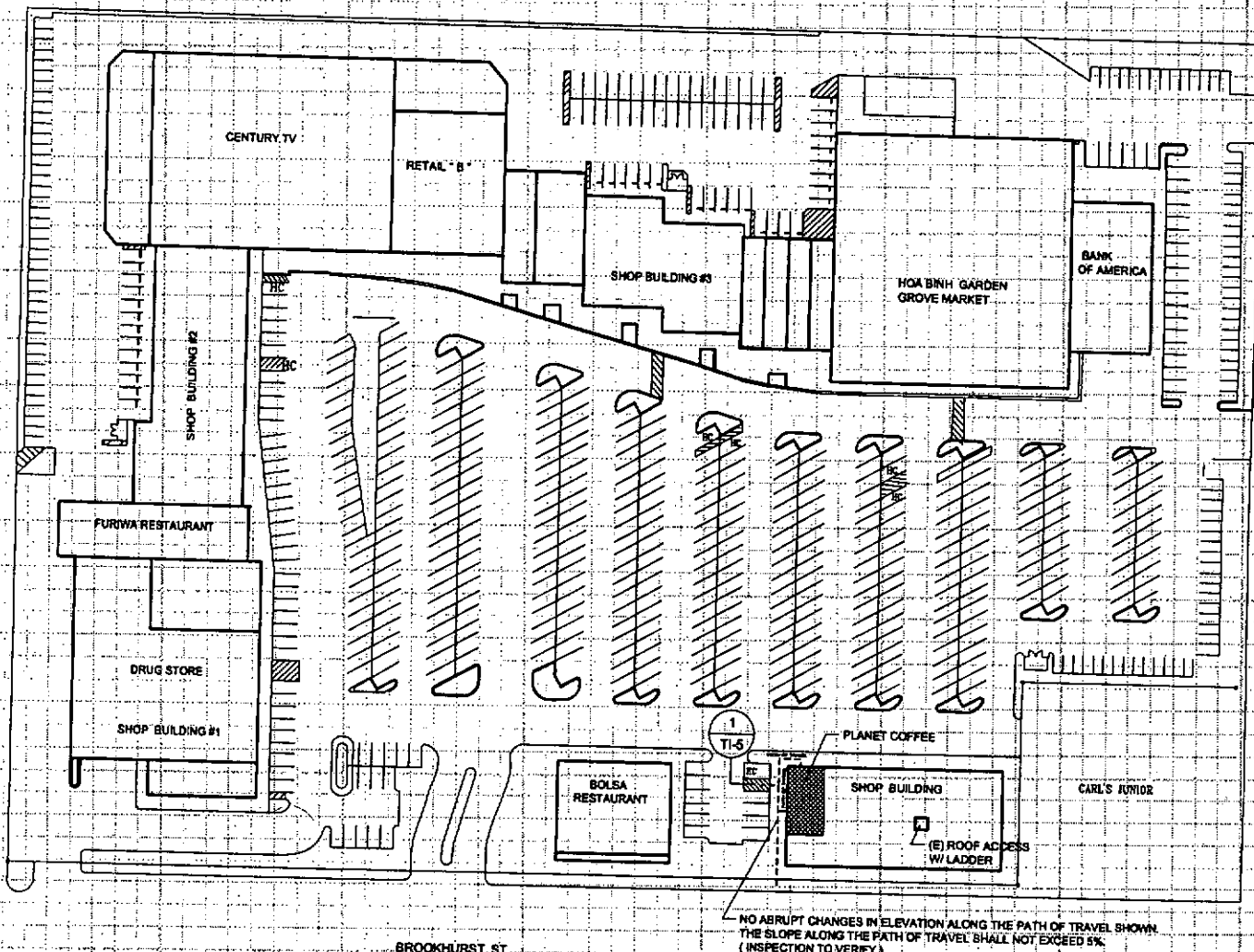

SITE PLAN
NOT TO SCALE



I certify the information hereon is complete & correct.

HUNG TRUNG DAM
Owner's Name (print)

Hung DAM
Signature (owner/agent)

10-16-08
Date



General Information: 714-741-5307

CITY OF GARDEN GROVE - DEVELOPMENT SERVICES DEPARTMENT

Inspection Requests: 714-741-5332

PERMIT (PAGE 2 of 2)

PROJECT/SITE/BUILDING DESCRIPTION

JOB Address : 13916 BROOKHURST ST
 Suite : A
 PERMIT NO. : 96745
 Permit Type : E
 Type : E
 Owner : TRUST CHOE, WINSTON
 Applicant :
 Phone :
 Contractor : SIGNEX
 Address : 10852 FORBES AVE #C2
 CityStZip : GARDEN GROVE, CA 92843
 Phone : 714-265-3710
 Insp Dist : SE
 Date : 12/22/08
 Parcel No : 09934413

PROPOSED WORK:

ELEC FOR 2 NEW ILLUMINATED WALL SIGNS

FEES

111 32401 Issuance	1	35.00
111 32412 Sign branch circuit	2	11.00
TOTAL		46.00

APPROVAL	DATE	INSPECTOR
Underground		
Conduit		
Wiring - Rough		
Heater		
Fixtures & Trim		
Motors		
Ufer		
Service		

Underground _____
 Conduit _____
 Wiring - Rough _____
 Heater _____
 Fixtures & Trim _____
 Motors _____
 Ufer _____
 Service _____

FINAL 1/6/09 [Signature]

Utility Notified _____

AUTHORIZATION

Issued By: yoavs Date _____

DECLARATION

I certify that I have read this application/permit and state that the information on all pages of this document is correct. I agree to comply with all City and County ordinances and State laws relating to building construction, and hereby authorize representatives of this City and County to enter upon the above mentioned property for inspection purposes.

Applicant's Signature [Signature]

Print Name TO NGO Date 12/24/08

***** VALIDATION *****

PAID ON 22 Dec 2008 AT 15:22
 RECEIVED BY EDWARD M 198.245.206.215 TRANS# 1094
 AMOUNT PAID \$261.36 BY CHECK
 TOTAL PAID = \$46.00



General Information: 714-741-5307

CITY OF GARDEN GROVE - DEVELOPMENT SERVICES DEPARTMENT

Inspection Request: 714-741-5332

PERMIT (PAGE 2 of 2)

PROJECT/SITE/BUILDING DESCRIPTION

JOB Address : 13916 BROOKHURST ST
 Suite : A
 PERMIT NO. : 96744
 Permit Type : SIGN
 Type : B11
 SIGNS
 Owner : TRUST CHOE, WINSTON
 Applicant :
 Phone :
 Contractor : SIGNEX
 Address : 10852 FORBES AVE #C2
 CityStZip : GARDEN GROVE, CA 92843
 Phone : 714-265-3710
 Insp Dist : SB 6
 Date : 12/22/08
 Parcel No : 09934413
 Value : 8200
 Floor area : 110

PROPOSED WORK:

O28 - SIGNS
 2 NEW ILLUMINATED WALL SIGNS

FEES

111 32410 Permit	1	164.00
111 32401 issuance	1	35.00
942 22130 General Plan	1	10.96
080 32550 Cultural Arts	1	5.40
TOTAL		215.36

APPROVAL DATE INSPECTOR

Pre Inspect _____
 Foundation _____
 Concrete Floor _____
 Reinforcing _____
 Masonry _____
 Roof Shtg _____
 Rough Frame _____
 Insul / Energy _____
 Drywall _____
 Lath _____
 Plas. Brown Ct. _____
 Landscaping _____
 Pre Gunita _____
 Pre Deck _____
 Pre Plaster _____
 Planning Final _____
 Bldg Final 1/4/09 *[Signature]*
 Utility Notified _____

AUTHORIZATION

Issued By: yoavs Date _____

DECLARATION

I certify that I have read this application/permit and state that the information on all pages of this document is correct. I agree to comply with all City and County ordinances and State laws relating to building construction, and hereby authorize representatives of this City and County to enter upon the above mentioned property for inspection purposes.

Applicant's Signature [Signature]
 Print Name TO NAO Date 12/21/08

***** VALIDATION *****
 PAID ON 22 Dec 2008 AT 15:22
 RECEIVED BY EDWARDM 198.245.206.215 TRANS# 10941
 AMOUNT PAID \$261.36 BY CHECK
 TOTAL PAID = \$215.36

COPY



General Information: 714-741-5307

CITY OF GARDEN GROVE - DEVELOPMENT SERVICES DEPARTMENT

Inspection Requests: 714-741-5332

PERMIT (PAGE 2 of 2)

PROJECT/SITE/BUILDING DESCRIPTION

JOB Address : 13916 BROOKHURST ST
 Suite : A
 PERMIT NO. : 96181
 Permit Type : BUILDING
 Type : B7
 ALTERATIONS TO OTHER BUILDINGS
 Owner : TRUST CHOE, WINSTON
 Applicant : KY NGUYEN
 Phone : 875-6877

Contractor : NDK CONSTRUCTION
 Address : 13121 NEWHOPE
 CityStZip : GARDEN GROVE, CA 92843
 Phone : 537-0873

Insp Dist : ZB
 Date : 10/22/08
 Parcel No : 09934413

Value : 20000
 Floor area : 0

PROPOSED WORK:

043 - T.I. COMMERCIAL

NEW COFFEE SHOP INCLUDING NEW PLUMBING PLANET COFFEE

FEES

111 32410 Permit	1	337.11
111 32401 issuance	1	35.00
942 22130 General Plan	1	24.79
080 32550 Cultural Arts	1	12.21
TOTAL		409.11

APPROVAL DATE INSPECTOR

Pre Inspect _____
 Foundation _____
 Concrete Floor _____
 Reinforcing _____
 Masonry _____
 Roof Shtg _____
 Rough Frame _____
 Insul / Energy _____
 Drywall _____
 Lath _____
 Plas. Brown Ct. _____
 Landscaping _____
 Pre Gunitite _____
 Pre Deck _____
 Pre Plaster _____

Planning Final _____

Bldg Final *RG 1/6/09 FINE*

Utility Notified _____

AUTHORIZATION

Issued By: _____ Date: _____

DECLARATION

I certify that I have read this application/permit and state that the information on all pages of this document is correct. I agree to comply with all City and County ordinances and State laws relating to building construction, and hereby authorize representatives of this City and County to enter upon the above mentioned property for inspection purposes.

Applicant's Signature _____

Print Name _____ Date _____



General Information: 714-741-5307

CITY OF GARDEN GROVE - DEVELOPMENT SERVICES DEPARTMENT

Inspection Requests: 714-741-5332

PERMIT (PAGE 2 of 2)



PROJECT/SITE/BUILDING DESCRIPTION

JOB Address : 13916 BROOKHURST ST
 Suite : AA
 PERMIT NO. : 96183
 Permit Type :
 Type : P

Owner : TRUST CHOE, WINSTON
 Applicant : KY NGUYEN
 Phone : 875-6877

Contractor : NDK CONSTRUCTION
 Address : 13121 NEWHOPE
 CityStZip : GARDEN GROVE, CA 92843
 Phone : 537-0873

Insp Dist : ZP
 Date : 10/22/08
 Parcel No : 09934413

PROPOSED WORK:

PLUMBING FOR T I COFFEE SHOP [

FEES

111 32401 Issuance	1	35.00
111 32415 WATER CLOSET, BIDET	2	19.00
111 32415 Lavatory	3	28.50
111 32415 Kitchen Sink	1	9.50
111 32415 Garbage Disposal	1	9.50
111 32415 Floor Drain	2	19.00
TOTAL		120.50

APPROVAL DATE INSPECTOR

Soil Piping _____
 Ground Plumbing _____
 Rough Plumbing 10/22/08
 Gas Piping _____
 Gas Vent _____
 Sewer _____
 Main Drain _____
 Vacuum Lines _____
 Water Heater _____
 Backwash _____
 Water Lateral _____

FINAL 12/14/08 [Signature]
 Utility Notified _____

AUTHORIZATION

Issued By: joannec Date _____

DECLARATION

I certify that I have read this application/permit and state that the information on all pages of this document is correct. I agree to comply with all City and County ordinances and State laws relating to building construction, and hereby authorize representatives of this City and County to enter upon the above mentioned property for inspection purposes.

Applicant's Signature Gieng Nguyen
 Print Name GIANG NGUYEN Date 10-22-08

***** VALIDATION *****
 PAID ON 22 Oct 2008 AT 15:13
 RECEIVED BY EDWARDM 198.245.206.215 TRANS# 917
 AMOUNT PAID \$6171.91 BY CHECK
 TOTAL PAID = \$120.50



General Information: 714-741-5307

CITY OF GARDEN GROVE - DEVELOPMENT SERVICES DEPARTMENT

Inspection Requests: 714-741-5332

PERMIT (PAGE 2 of 2)

PROJECT/SITE/BUILDING DESCRIPTION

JOB Address : 13916 BROOKHURST ST
 Suite : A
 PERMIT NO. : 96184
 Permit Type :
 Type : H
 Owner : TRUST CHOE, WINSTON
 Applicant : KY NGUYEN
 Phone : 875-6877
 Contractor : NDK CONSTRUCTION
 Address : 13121 NEWHOPE
 CityStZip : GARDEN GROVE, CA 92843
 Phone : 537-0873
 Insp Dist : ZH
 Date : 10/22/08
 Parcel No : 09934413

PROPOSED WORK:

MECHANICAL FOR T I COFFEE SHOP

FEES

111 32401 Issuance	1	35.00
111 32418 A/C COND UNIT TO 5 T	1	10.00
TOTAL		45.00

APPROVAL . DATE INSPECTOR

Furnace _____
 Furnace Vents _____
 Gas Piping _____
 Ducts 10/24/08 ANT _____
 Duct Fan vent _____
 Kitchen Hood _____
 Air Handl Unit _____
 Evap Cooler _____
 Boiler Comp _____
 Decor Appl _____

FINAL 12/10/08 [Signature] _____
 Utility Notified _____

AUTHORIZATION

Issued By: joannec Date _____

DECLARATION

I certify that I have read this application/permit and state that the information on all pages of this document is correct. I agree to comply with all City and County ordinances and State laws relating to building construction, and hereby authorize representatives of this City and County to enter upon the above mentioned property for inspection purposes.

Applicant's Signature [Signature]
 Print Name GIANH NGUYEN Date 10-22-08

***** VALIDATION *****
 PAID ON 22 Oct 2008 AT 15:13
 RECEIVED BY EDWARD M 198.245.206.215 TRANS# 917
 AMOUNT PAID \$6171.91 BY CHECK
 TOTAL PAID = \$45.00



PERMIT (PAGE 2 of 2)

PROJECT/SITE/BUILDING DESCRIPTION

JOB Address : 13916 BROOKHURST ST
 Suite :
 PERMIT NO. : 96668
 Permit Type :
 Type : E

Owner : TRUST CHOE, WINSTON
 Applicant : KY DUC NGUYEN
 Phone : 875-6877

Contractor : NDK CONSTRUCTION
 Address : 13121 NEWHOPE
 CityStZip : GARDEN GROVE, CA 92843
 phone : 537-0873

Insp Dist : ZE
 Date : 12/11/08
 Parcel No : 09934413

PROPOSED WORK:

SUPP TO PERMIT 96182 UPGRADE ELECTRICAL PANEL

FEES

111 32412 SERVICE 600V, 200A M	1	30.00
111 32401 SUPPLEMENTAL PERMIT/	1	15.00
TOTAL		45.00

APPROVAL DATE INSPECTOR

Underground _____
 Conduit _____
 Wiring - Rough _____
 Heater _____
 Fixtures & Trim _____
 Motors _____
 Ufer _____
 Service _____

FINAL

12/23/08 [Signature]

Utility Notified _____

AUTHORIZATION

Issued By: joannec Date _____

DECLARATION

I certify that I have read this application/permit and state that the information on all pages of this document is correct. I agree to comply with all City and County ordinances and State laws relating to building construction, and hereby authorize representatives of this City and County to enter upon the above mentioned property for inspection purposes.

Applicant's Signature [Signature]

Print Name Ky D Nguyen Date 12-11-08

***** VALIDATION *****
 PAID ON 11 Dec 2008 AT 14:53
 RECEIVED BY EDWARDM 198.245.206.215 TRANS# 8729
 CASH PAID = \$45.00 CASH RETURNED = \$0.00
 TOTAL PAID = \$45.00



PERMIT (PAGE 2 of 2)

PROJECT/SITE/BUILDING DESCRIPTION

JOB Address : 13916 BROOKHURST ST
 Suite : A
 PERMIT NO. : 96182
 Permit Type :
 Type : E

Owner : TRUST CHOE, WINSTON
 Applicant : KY NGUYEN
 Phone : 875-6877

Contractor : NDK CONSTRUCTION
 Address : 13121 NEWHOPE
 CityStZip : GARDEN GROVE, CA 92843
 Phone : 537-0873

Insp Dist : ZE
 Date : 10/22/08
 Parcel No : 09934413

PROPOSED WORK:

ELECTRICAL FOR T I

FEES

111 32401	Issuance	1	35.00
111 32412	OUTLETS 1-20 ea	20	20.00
111 32412	Fixtures (1-20)	20	20.00
111 32412	Fixtures (over 20)	20	15.00
111 32412	Water Heater	1	9.50
TOTAL			99.50

APPROVAL DATE INSPECTOR

Underground _____
 Conduit _____
 Wiring - Rough _____
 Heater _____
 Fixtures & Trim _____
 Motors _____
 Ufer _____
 Service _____

FINAL 12/23/08 [Signature]
 Utility Notified _____

***** VALIDATION *****
 PAID ON 22 Oct 2008 AT 15:13
 RECEIVED BY EDWARDM 198.245.206.215 TRANS# 917
 AMOUNT PAID \$6171.91 BY CHECK
 TOTAL PAID = \$99.50

AUTHORIZATION

Issued By: joannec Date _____

DECLARATION

I certify that I have read this application/permit and state that the information on all pages of this document is correct. I agree to comply with all City and County ordinances and State laws relating to building construction, and hereby authorize representatives of this City and County to enter upon the above mentioned property for inspection purposes.

Applicant's Signature [Signature]

Print Name GIANG NGUYEN date 10-22-08



PERMIT (PAGE 2 of 2)



PROJECT/SITE/BUILDING DESCRIPTION

JOB Address : 13916 BROOKHURST ST
 Suite : F
 PERMIT NO. : 78091
 Permit Type : SIGN
 Type : B11
 SIGNS
 Owner : WINSTON CHOE
 Applicant : T SIGNS
 Appl Address : 15151 MORAN ST
 WESTMINSTER, CA 92683
 Phone : 890-0932
 Insp Dist : SB
 Date : 02/28/05
 Parcel No : 09934413

Value : 3100
 Floor area : 112

PROPOSED WORK:

2 CHANNEL LETTER SIGNS ON EX. CIRCUITS

FEES

111 32410 Permit	1	62.00
111 32401 issuance	1	35.00
942 22130 General Plan	1	4.98
080 32550 Cultural Arts	1	2.45
TOTAL		104.43

INSPECTION RECORD

APPROVAL	DATE	INSPECTOR
Pre Inspect	_____	_____
Foundation	_____	_____
Concrete Floor	_____	_____
Reinforcing	_____	_____
Masonry	_____	_____
Roof Shtg	_____	_____
Rough Frame	_____	_____
Insul / Energy	_____	_____
Drywall	_____	_____
Lath	_____	_____
Plas. Brown Ct.	_____	_____
Landscaping	_____	_____
Pre Gunitite	_____	_____
Pre Deck	_____	_____
Pre Plaster	_____	_____
Planning Final	_____	_____
Bldg Final	4-13-05 T.H	_____
Utility Notified	_____	_____

AUTHORIZATION

Issued By: yoavs _____ Date _____

DECLARATION

I certify that I have read this application/permit and state that the information on all pages of this document is correct. I agree to comply with all City and County ordinances and State laws relating to building construction, and hereby authorize representatives of this City and County to enter upon the above mentioned property for inspection purposes.

Applicant's Signature Thuy Kim Ho
 Print Name THUY KIM HO Date Feb 29/05

***** VALIDATION *****
 PAID ON 28 Feb 2005 AT 13:11
 RECEIVED BY RONP 198.245.206.215/2 TRANS# 152
 CASH PAID = \$104.43 CASH RETURNED = \$0.00
 TOTAL PAID = \$104.43

Plot Plan Form

Planning Action:	Zone: <u>C-1</u>	Coverage:	Job Address: <u>13916 BROOKHURST ST.</u>	Permit No.: <u>78091</u>
Approved By: <u>MP for NB</u>	Date: <u>2/28/05</u>	Increase:	Assessor Parcel No.: <u>099 34413</u>	Tract & Lot #:
Remarks:			Occupancy:	Const. Type:
			<input type="checkbox"/> New	<input type="checkbox"/> Alter <input checked="" type="checkbox"/> Add <input type="checkbox"/> Repair <input type="checkbox"/> Demo

Job Description:
 Brookhurst & Westminster
 Individual demand letter

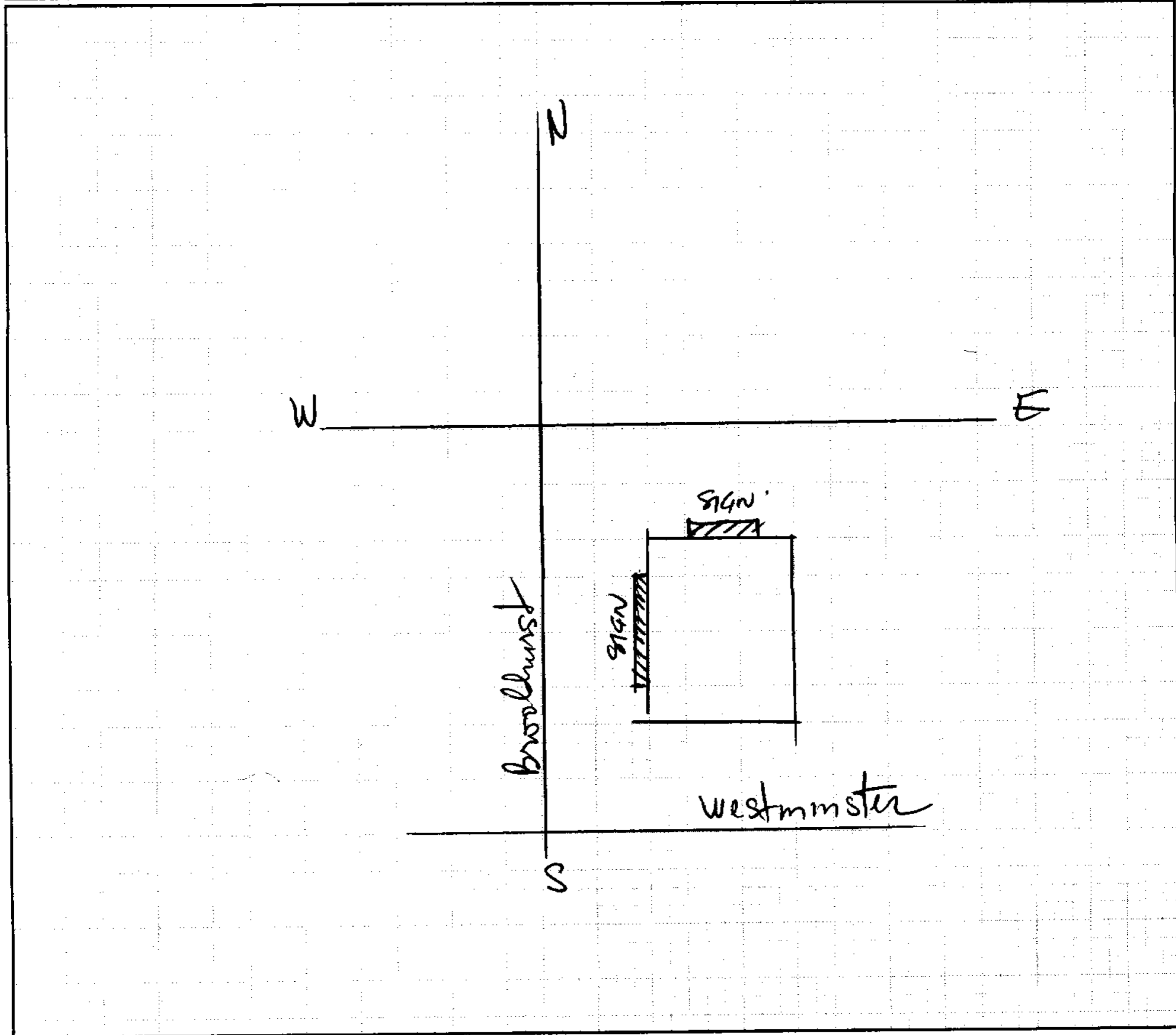

I certify the information hereon is complete & correct.

THY 100

Owner's Name (print)

Thuy Ly Ho
 Signature (owner/agent)

Date



General Information: 714-741-5307

CITY OF GARDEN GROVE - DEVELOPMENT SERVICES DEPARTMENT

Inspection Requests: 714-741-5332

PERMIT (PAGE 2 of 2)

PROJECT/SITE/BUILDING DESCRIPTION

JOB Address : 13916 BROOKHURST ST
 Suite : F
 PERMIT NO. : 77951
 Permit Type :
 Type : H

Owner : WINSTON CHOE
 Applicant : PGT CONSTRUCTION
 Appl Address : 2118 POTRERO AVE
 EL MONTE, CA 91733
 Phone : 626 350-8005

Insp Dist : ZH
 Date : 02/16/05
 Parcel No : 09934413

PROPOSED WORK:

MECH FOR T.I. FOR OPTOMETRIST OFFICE

FEES

942 22130 GENERAL PLAN	1	2.00
080 32550 CULTURAL ARTS	1	1.00
111 32401 Issuance	1	35.00
111 32418 DUCTS	1	12.00
TOTAL		50.00

APPROVAL DATE INSPECTOR

INSPECTION RECORD

Furnace _____
 Furnace Vents _____
 Gas Piping _____
 Ducts 3-1-05 Av
 Duct Fan Vent _____
 Kitchen Hood _____
 Air Handl Unit _____
 Evap Cooler _____
 Boiler Comp _____
 Decor Appl _____

FINAL 3/24/05 [Signature]

Utility Notified _____

AUTHORIZATION

Issued By: yoavs Date _____

DECLARATION

I certify that I have read this application/permit and state that the information on all pages of this document is correct. I agree to comply with all City and County ordinances and State laws relating to building construction, and hereby authorize representatives of this City and County to enter upon the above mentioned property for inspection purposes.

Applicant's Signature [Signature]

Print Name THU TRAN Date 2/16/05

***** VALIDATION *****
 PAID ON 16 Feb 2005 AT 10:18
 RECEIVED BY RONP 198.245.206.215/2 TRANS# 33
 CASH PAID = \$100.00 CASH RETURNED = \$0.30
 TOTAL PAID = \$99.70



PERMIT (PAGE 2 of 2)

PROJECT/SITE/BUILDING DESCRIPTION

JOB Address : 13916 BROOKHURST ST
 Suite : F
 PERMIT NO. : 77950
 Permit Type :
 Type : E

Owner : WINSTON CHOE
 Applicant : PGT CONSTRUCTION
 Appl Address : 2118 POTRERO AVE
 EL MONTE, CA 91733
 Phone : 626 350-8005

Insp Dist : ZE
 Date : 02/16/05
 Parcel No : 09934413

PROPOSED WORK:

ELEC FOR T.I. FOR OPTOMETRIST OFFICE

FEES

942 22130 GENERAL PLAN	1	2.00
080 32550 CULTURAL ARTS	1	1.00
111 32401 Issuance	1	35.00
111 32412 OUTLETS 1-10	10	9.00
111 32412 Fixtures 1-10	3	2.70
TOTAL		49.70

APPROVAL DATE INSPECTOR
INSPECTION RECORD
 Underground
 Conduit
 Wiring - Rough
 Heater
 Fixtures & Trim
 Motors
 Ufer
 Service

FINAL 3-22-05 T.H.
 Utility Notified

AUTHORIZATION

Issued By: yoavs Date

DECLARATION

I certify that I have read this application/permit and state that the information on all pages of this document is correct. I agree to comply with all City and County ordinances and State laws relating to building construction, and hereby authorize representatives of this City and County to enter upon the above mentioned property for inspection purposes.

Applicant's Signature

Print Name DAVID TRABA Date 2/16/05

***** VALIDATION *****
 PAID ON 16 Feb 2005 AT 10:18
 RECEIVED BY RONP 198.245.206.215/2 TRANS# 33
 CASH PAID = \$100.00 CASH RETURNED = \$0.30
 TOTAL PAID = \$99.70



PERMIT (PAGE 2 of 2)

PROJECT/SITE/BUILDING DESCRIPTION

JOB Address : 13916 BROOKHURST ST
 Suite : F
 PERMIT NO. : 77901
 Permit Type : BUILDING
 Type : B7
 ALTERATIONS TO OTHER BUILDINGS
 Owner : WINSTON CHOE
 Applicant : OWNER
 Appl Address : 13916 BROOKHURST ST

Phone :
 Insp Dist : ZB
 Date : 02/11/05
 Parcel No : 09934413

Value : 20000
 Floor area : 1220

PROPOSED WORK:

T.I. FOR OPTOMETRIST OFFICE

FEES

111 32509 Plan Check	1	241.03
111 32410 Permit	1	337.11
111 32401 issuance	1	35.00
942 22130 General Plan	1	24.79
080 32550 Cultural Arts	1	12.21
111 32509 PLAN CHECK FEE CREDI	1	-241.03
TOTAL		409.11

INSPECTION RECORD

APPROVAL	DATE	INSPECTOR
Pre Inspect		
Foundation		
Concrete Floor		
Reinforcing		
Masonry		
Roof Shtg		
Rough Frame	2/20/05	[Signature]
Insul / Energy		
Drywall	2/3/05	[Signature]
Lath		
Plas. Brown Ct.		
Landscaping		
Pre Gunit		
Pre Deck		
Pre Plaster		
Planning Final		
Bldg Final	2/30/05	[Signature]
Utility Notified		

AUTHORIZATION

Issued By: yoavs Date

DECLARATION

I certify that I have read this application/permit and state that the information on all pages of this document is correct. I agree to comply with all City and County ordinances and State laws relating to building construction, and hereby authorize representatives of this City and County to enter upon the above mentioned property for inspection purposes.

Applicant's Signature [Signature]
 Print Name PHI DAN Date 2/11/05

***** VALIDATION *****
 PAID ON 11 Feb 2005 AT 09:12
 RECEIVED BY RONP 198.245.206.215/2 TRANS# 49
 CASH PAID = \$410.00 CASH RETURNED = \$0.89
 TOTAL PAID = \$409.11

CITY OF GARDEN GROVE - COMMUNITY DEVELOPMENT DEPARTMENT
Plot Plan Form

Planning Action:	Zone:	Coverage:	Job Address: 13916-F Brookhurst St.	Permit No.: 77901
Approved By: <i>[Signature]</i>	Date: 2/11/05	Increase:	Assessor Parcel No.: 099 34413	Tract & Lot #:
Remarks:			Occupancy:	Const. Type: T.I.
			Value: \$20,000	
			<input type="checkbox"/> New <input checked="" type="checkbox"/> Alter <input type="checkbox"/> Add <input type="checkbox"/> Repair <input type="checkbox"/> Demo	

Job Description: WALL PARTITIONS, ELECTRICAL OUTLETS, PAINT, NEW CARPET.
 FOR OPTOMETRIST OFFICE.

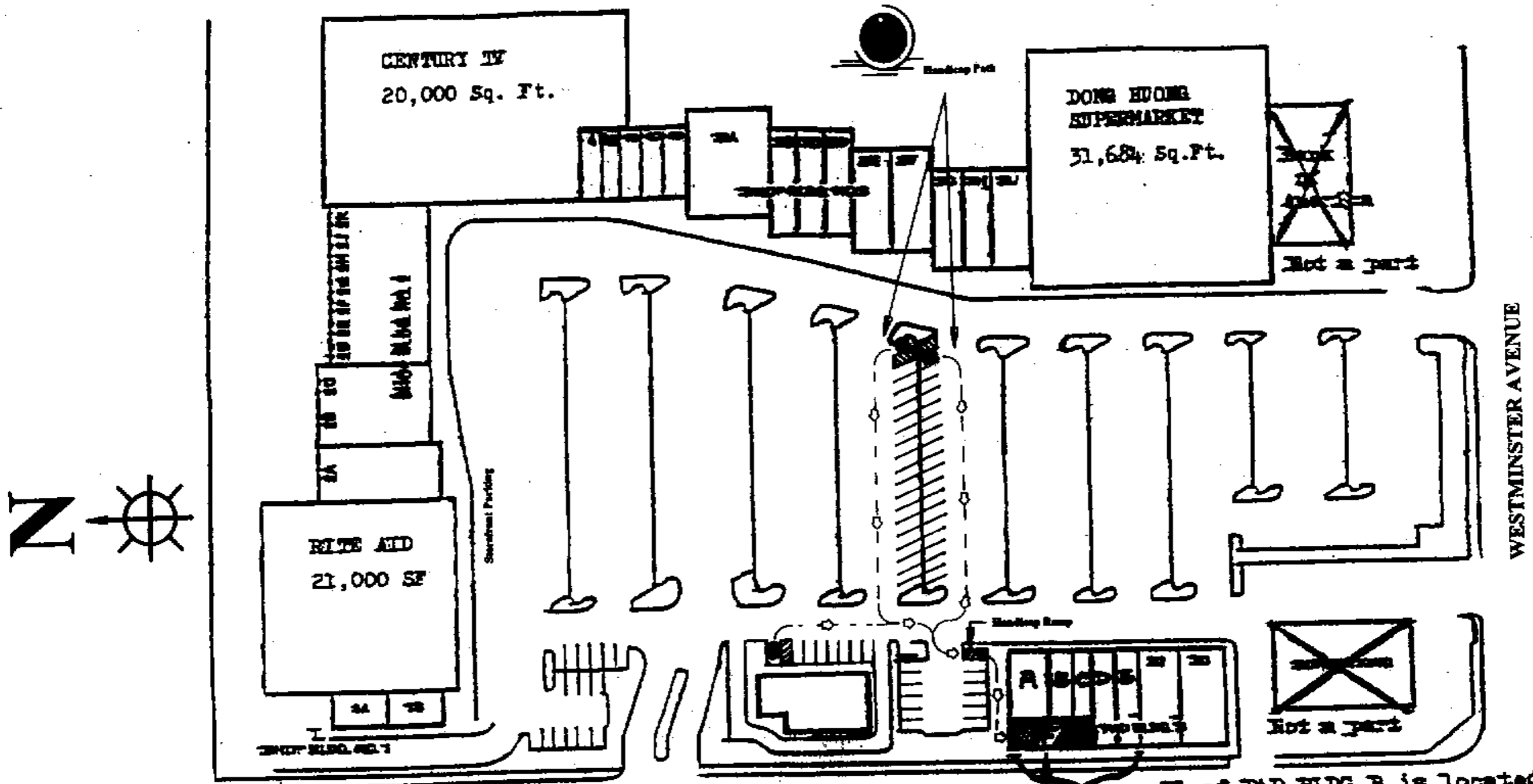

SI of PAD BLDG B is located at 13916 Brookhurst St. The SI has six (6) stores: 13916

SUMMARY		SHOP BUILDING 1		SHOP BUILDING 2		SHOP BUILDING 3		SHOP BUILDING 4		PAD BUILDING B	
Dong Huong Supermarket	31,684 SF	Shop A1	1,000 SF	Shop B1	1,000 SF	Shop C1	1,000 SF	Shop D1	1,000 SF	Shop B1	1,000 SF
Century IV	20,000 SF	Shop A2	1,000 SF	Shop B2	1,000 SF	Shop C2	1,000 SF	Shop D2	1,000 SF	Shop B2	1,000 SF
White AID	21,000 SF	Shop A3	1,000 SF	Shop B3	1,000 SF	Shop C3	1,000 SF	Shop D3	1,000 SF	Shop B3	1,000 SF
Bank of America	6,500 SF (not a part)	Shop A4	1,000 SF	Shop B4	1,000 SF	Shop C4	1,000 SF	Shop D4	1,000 SF	Shop B4	1,000 SF
TOTAL BLDG AREA	131,513 SF	TOTAL	4,000 SF	TOTAL	4,000 SF	TOTAL	4,000 SF	TOTAL	4,000 SF	TOTAL	4,000 SF

Tenant's space is 13916-F marked as F above.

DR. PHI DOAN OPTOMETRY
 13916-F BROOKHURST ST., GARDEN GROVE, CA 92643

I certify the information hereon is complete & correct.

PHI DOAN Owner's Name (print) *[Signature]* Signature (owner/agent) 2/11/05 Date



PERMIT (PAGE 2 of 2)

PROJECT/SITE/BUILDING DESCRIPTION

JOB Address : 13916 BROOKHURST ST
 Suite :
 PERMIT NO. : 78810
 Permit Type :
 Type : E

Owner : WINSTON CHOE
 Applicant : T SIGNS
 Appl Address : 15151 MORAN ST
 WESTMINSTER, CA 92683

Phone : 890-0932

Insp Dist : SE
 Date : 04/12/05
 Parcel No : 09934413

PROPOSED WORK:

ELEC FOR (2) CHANNEL LETTER WALL SIGNS.

FEES

942 22130 GENERAL PLAN	1	2.00
080 32550 CULTURAL ARTS	1	1.00
111 32401 Issuance	1	35.00
111 32412 addt circuits same d	2	12.00
TOTAL		50.00

APPROVAL	DATE	INSPECTOR
Underground		
Conduit		
Wiring - Rough		
Heater		
Fixtures & Trim		
Motors		
Ufer		
Service		

FINAL 4-13-05 T.H

Utility Notified _____

AUTHORIZATION

Issued By: jimc Date _____

DECLARATION

I certify that I have read this application/permit and state that the information on all pages of this document is correct. I agree to comply with all City and County ordinances and State laws relating to building construction, and hereby authorize representatives of this City and County to enter upon the above mentioned property for inspection purposes.

Applicant's Signature [Signature]
 Print Name T.H. Y. Ho Date Apr 12/05

***** VALIDATION *****
 PAID ON 12 Apr 2005 AT 08:11
 RECEIVED BY RONP 198.245.206.215/2 TRANS# 2
 CASH PAID = \$50.00 CASH RETURNED = \$0.00
 TOTAL PAID = \$50.00



PERMIT (PAGE 2 of 2)

PROJECT/SITE/BUILDING DESCRIPTION

JOB Address : 13916 BROOKHURST ST
 Suite :
 PERMIT NO. : 44052
 Permit Type :
 Type : P

Owner : CHOE, WINSTON
 Applicant : T & T CONSTRUCTION SERVICES
 Appl Address : 14246 OLIVE
 WESTMINSTER, CA 92683
 Phone : 891 2153

Insp Dist : ZP
 Date : 08/14/98
 Parcel No : 09934413

PROPOSED WORK:

WATER LINE FOR NEW METER

FEES

942 22130 GENERAL PLAN	1	2.00
080 32550 CULTURAL ARTS	1	1.00
111 32401 Issuance	1	30.00
111 32415 Water Piping (ea. 10	1	10.00
111 32415 MINIMUM PLUMBING FEE	1	15.00
TOTAL		58.00

APPROVAL DATE INSPECTOR
INSPECTION RECORD

Soil Piping _____
 Ground Plumbing _____
 Rough Plumbing _____
 Gas Piping _____
 Gas Vent _____
 Sewer _____
 Main Drain _____
 Vacuum Lines _____
 Water Heater _____
 Backwash _____
 Water Lateral _____

FINAL 2/14/00 Amore ✓
 Utility Notified _____

AUTHORIZATION

Issued By: janetw Date _____

DECLARATION

I certify that I have read this application/permit and state that the information on all pages of this document is correct. I agree to comply with all City and County ordinances and State laws relating to building construction, and hereby authorize representatives of this City and County to enter upon the above mentioned property for inspection purposes.

Applicant's Signature Tu Nguyen

Print Name TU NGUYEN Date 8-14-98

***** VALIDATION *****
 PAID ON 14 Aug 1998 AT 14:12
 RECEIVED BY DOXIE 198.245.206.215/2 TRANS# 97
 AMOUNT PAID \$58.00 BY CHECK#1913
 TOTAL PAID = \$58.00



PERMIT (PAGE 2 of 2)

PROJECT/SITE/BUILDING DESCRIPTION

JOB Address : 13916 BROOKHURST ST
 Suite : F
 PERMIT NO. : 51321
 Permit Type : SIGN
 Type : B11
 SIGNS
 Owner : WINSTON CHOE
 Applicant : BUTTERFLY SIGNS
 Appl Address : 8109 BOLSA AVE
 MIDWAY CITY, CA 92655
 Phone : 894-0076

Insp Dist : SB
 Date : 02/10/00
 Parcel No : 09934413

Value :2250
 Floor area :0

PROPOSED WORK:

INSTALL (2) CHANNEL LETTER WALL SIGNS. " DOLLAR \$XPRESS. (16" X 16') & (20"X24').

FEES

111 32509 Plan Check	1	53.30
111 32410 Permit	1	82.00
111 32401 issuance	1	35.00
942 22130 General Plan	1	10.96
080 32550 Cultural Arts	1	5.40
TOTAL		186.66

INSPECTION RECORD

APPROVAL	DATE	INSPECTOR
Pre Inspect		
Foundation		
Concrete Floor		
Reinforcing		
Masonry		
Roof Shtg		
Rough Frame		
Insul / Energy		
Drywall		
Lath		
Plas. Brown Ct.		
Landscaping		
Pre Gunite		
Pre Deck		
Pre Plaster		
Planning Final		
Bldg Final	3-22-00	<i>[Signature]</i>
Utility Notified		

AUTHORIZATION

Issued By: dianeb Date _____

DECLARATION

I certify that I have read this application/permit and state that the information on all pages of this document is correct. I agree to comply with all City and County ordinances and State laws relating to building construction, and hereby authorize representatives of this City and County to enter upon the above mentioned property for inspection purposes.

Applicant's Signature *[Signature]*
 Print Name PHUONG NGUYEN Date 2/10/00

***** VALIDATION *****
 PAID ON 10 Feb 2000 AT 14:46
 RECEIVED BY KRISTINB 198.245.206.215/2 TRANS# 64
 AMOUNT PAID \$235.66 BY CHECK#651
 TOTAL PAID = \$235.66

Plot Plan Form

Planning Action: <u>AP 772004</u>	Zone: <u>C-2</u>	Coverage:	Job Address: <u>13916 BROOKHURST HT</u>	Permit No.: <u>51321</u>
Approved By: <u>[Signature]</u>	Date: <u>2/10</u>	Increase:	Assessor Parcel No.: <u>099344177</u>	Tract & Lot #:
Remarks:			Occupancy:	Const. Type: <u>Sign</u>
			<input checked="" type="checkbox"/> New	<input type="checkbox"/> Alter <input type="checkbox"/> Add <input type="checkbox"/> Repair <input type="checkbox"/> Demo
Value: <u>2,250</u>				

Job Description: ~~2~~ 16" x 16" CHANNEL LETTER SIGN
20" x 24" CHANNEL LETTER SIGN

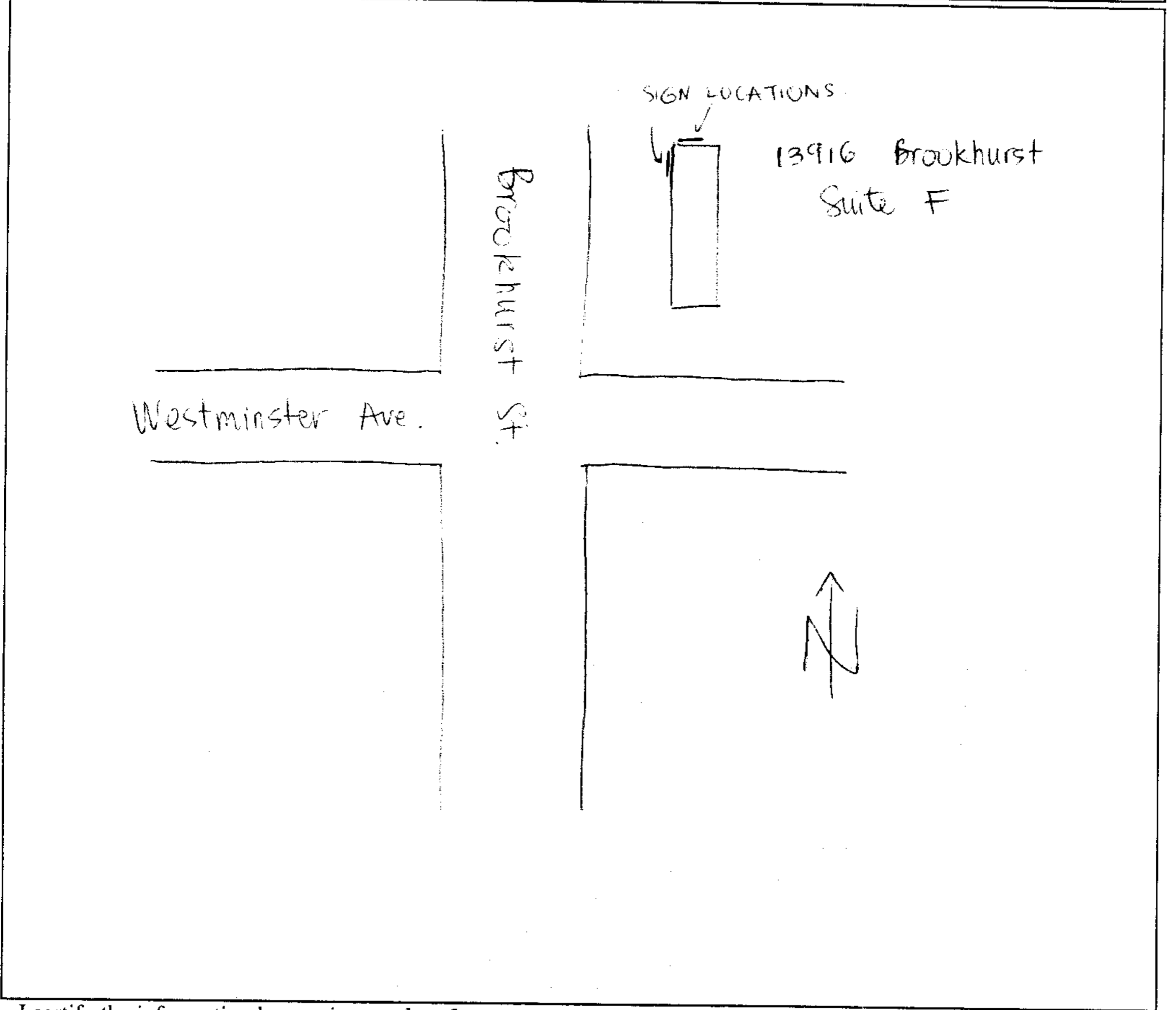

I certify the information hereon is complete & correct.

PHUONG NGUYEN Owner's Name (print) [Signature] (Signature) (owner/agent) 2/10/00 Date

WHITE: INSPECTION YELLOW: ASSESSOR PINK: PERMITTEE



PERMIT (PAGE 2 of 2)

PROJECT/SITE/BUILDING DESCRIPTION

JOB Address : 13916 BROOKHURST ST
 Suite :
 PERMIT NO. : 51322
 Permit Type :
 Type : E
 Owner : WINSTON CHOE
 Applicant : BUTTERFLY SIGNS
 Appl Address : 8109 BOLSA AVE
 MIDWAY CITY, CA 92655
 Phone : 894-0076
 Insp Dist : SE
 Date : 02/10/00
 Parcel No : 09934413

PROPOSED WORK:

INSTALL (2) CHANNEL LETTER WALL SIGNS.
 "DOLLAR \$XPRESS"

FEES

942 22130 GENERAL PLAN	1	2.00
080 32550 CULTURAL ARTS	1	1.00
111 32401 Issuance	1	35.00
111 32412 SIGN BRANCH CIRCUITS	2	11.00
TOTAL		49.00

APPROVAL _____ DATE _____ INSPECTOR _____
INSPECTION RECORD

Underground _____
 Conduit _____
 Wiring - Rough _____
 Heater _____
 Fixtures & Trim _____
 Motors _____
 Ufer _____
 Service _____

FINAL 3-22-00 [Signature]

Utility Notified _____

AUTHORIZATION

Issued By: dianeb Date _____

DECLARATION

I certify that I have read this application/permit and state that the information on all pages of this document is correct. I agree to comply with all City and County ordinances and State laws relating to building construction, and hereby authorize representatives of this City and County to enter upon the above mentioned property for inspection purposes.

Applicant's Signature [Signature]

Print Name PHUONG NGUYEN Date 2/10/00

***** VALIDATION *****
 PAID ON 10 Feb 2000 AT 14:46
 RECEIVED BY KRISTINB 198.245.206.215/2 TRANS# 6
 AMOUNT PAID \$235.66 BY CHECK#651
 TOTAL PAID = \$235.66



PERMIT (PAGE 2 of 2)

PROJECT/SITE/BUILDING DESCRIPTION

JOB Address : 13916 BROOKHURST ST
 Suite : F
 PERMIT NO. : 51228
 Permit Type : SIGN
 Type : B11
 SIGNS
 Owner : WINSTON CHOE
 Applicant : BUTTERFLY SIGNS
 Appl Address : 8109 BOLSA AVE
 MIDWAY CITY, CA 92655
 Phone : 894-0076

Insp Dist : SB
 Date : 01/28/00
 Parcel No : 09934413

Value : 8200
 Floor area : 0

PROPOSED WORK:

ONE WALL SIGN

FEES

111 32509 Plan Check	1	53.30
111 32410 Permit	1	82.00
111 32401 issuance	1	35.00
942 22130 General Plan	1	10.96
080 32550 Cultural Arts	1	5.40
TOTAL		186.66

INSPECTION RECORD

APPROVAL	DATE	INSPECTOR
----------	------	-----------

Pre Inspect _____
 Foundation _____
 Concrete Floor _____
 Reinforcing _____
 Masonry _____
 Roof Shtg _____
 Rough Frame _____
 Insul / Energy _____
 Drywall _____
 Lath _____
 Plas. Brown Ct. _____
 Landscaping _____
 Pre Gunite _____
 Pre Deck _____
 Pre Plaster _____

 Planning Final _____

AUTHORIZATION

Issued By: janetw Date _____

DECLARATION

I certify that I have read this application/permit and state that the information on all pages of this document is correct. I agree to comply with all City and County ordinances and State laws relating to building construction, and hereby authorize representatives of this City and County to enter upon the above mentioned property for inspection purposes.

Applicant's Signature [Signature]
 Print Name PHUONG NGUYEN Date 1/28/2000

Bldg Final 3-22-00 [Signature]

Utility Notified _____

***** VALIDATION *****
 PAID ON 28 Jan 2000 AT 14:10
 RECEIVED BY CAROLH 198.245.206.215/2 TRANS# 72
 AMOUNT PAID \$254.66 BY CHECK#628
 TOTAL PAID = \$254.66

Plot Plan Form

Planning Action: <u>APPROVED</u>	Zone: <u>C-2</u>	Coverage:	Job Address: <u>13916 BROOKHURST #F</u>	Permit No.: <u>51228</u>
Approved By: <u>[Signature]</u>	Date: <u>1/28/2000</u>	Increase:	Assessor Parcel No.:	Tract & Lot #:
Remarks:			Occupancy:	Const. Type:
			<input checked="" type="checkbox"/> New	<input type="checkbox"/> Alter <input type="checkbox"/> Add <input type="checkbox"/> Repair <input type="checkbox"/> Demo
			Value: <u>8200</u>	

Job Description:

① ILLUMINATED CHANNEL LETTER WALL SIGN
TO READ "DIVA COSMO"

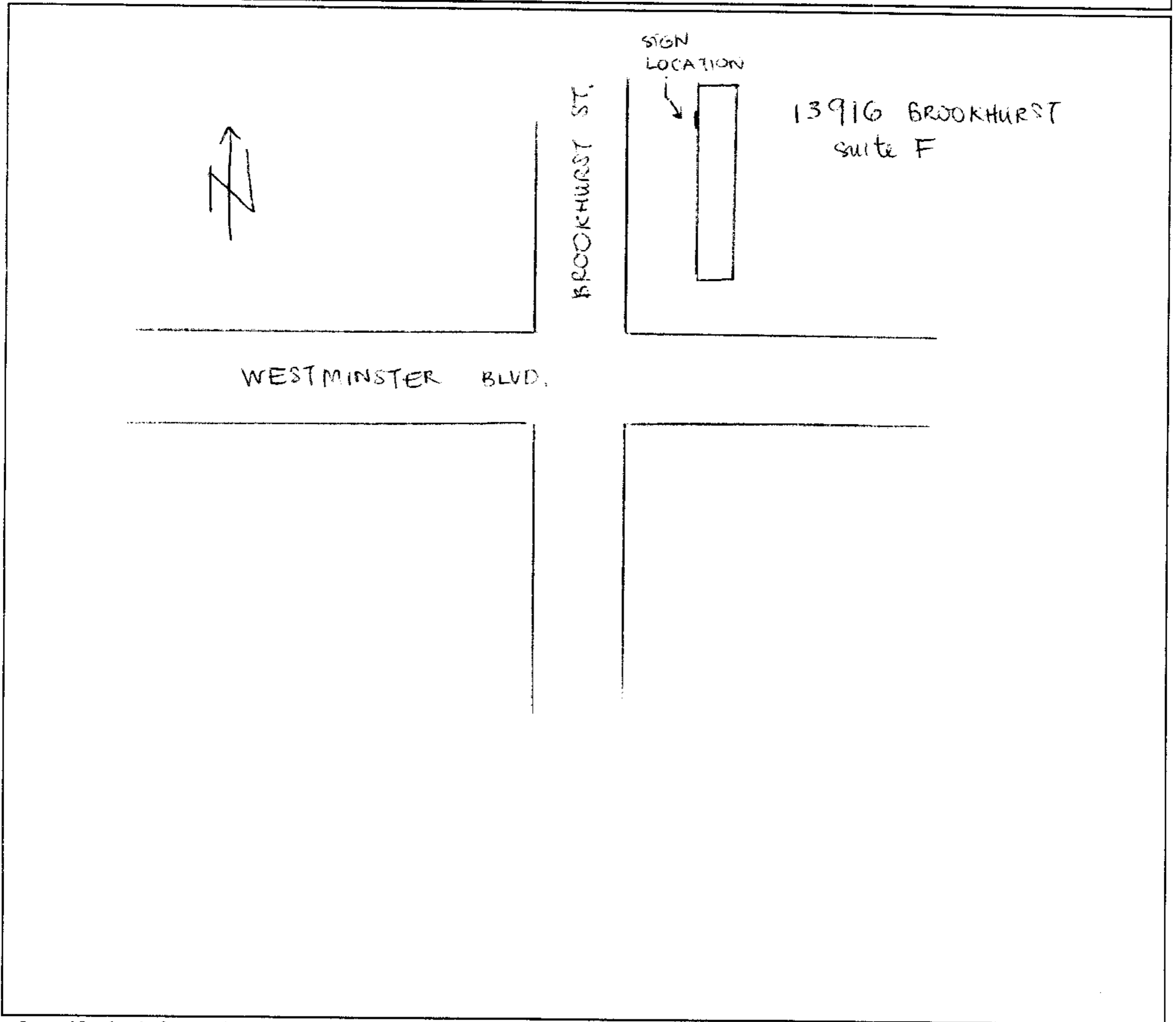

I certify the information hereon is complete & correct.

PHUONG NGUYEN
Owner's Name (print)

[Signature]
Signature (owner/agent)

1/24/2000
Date

WHITE: INSPECTION

YELLOW: ASSESSOR

PINK: PERMITTEE



PERMIT (PAGE 2 of 2)

PROJECT/SITE/BUILDING DESCRIPTION

JOB Address : 13916 BROOKHURST ST
 Suite : F
 PERMIT NO. : 51229
 Permit Type :
 Type : E

Owner : WINSTON CHOE
 Applicant : BUTTERFLY SIGNS
 Appl Address : 8109 BOLSA AVE
 MIDWAY CITY, CA 92655
 Phone : 894-0076

Insp Dist : SE
 Date : 01/28/00
 Parcel No : 09934413

PROPOSED WORK:

ONE WALL SIGN

FEES

942 22130 GENERAL PLAN	1	2.00
080 32550 CULTURAL ARTS	1	1.00
111 32401 Issuance	1	35.00
111 32412 lght&marquees(1 bran	1	30.00
TOTAL		68.00

APPROVAL DATE INSPECTOR

INSPECTION RECORD

Underground _____
 Conduit _____
 Wiring - Rough _____
 Heater _____
 Fixtures & Trim _____
 Motors _____
 Ufer _____
 Service _____

FINAL 3,22-00 *[Signature]*

Utility Notified _____

AUTHORIZATION

Issued By: janetw Date _____

DECLARATION

I certify that I have read this application/permit and state that the information on all pages of this document is correct. I agree to comply with all City and County ordinances and State laws relating to building construction, and hereby authorize representatives of this City and County to enter upon the above mentioned property for inspection purposes.

Applicant's Signature *[Signature]*

Print Name PHUONG NGUYEN Date 1/28/2000

***** VALIDATION *****
 PAID ON 28 Jan 2000 AT 14:10
 RECEIVED BY CAROLH 198.245.206.215/2 TRANS# 72
 AMOUNT PAID \$254.66 BY CHECK#628
 TOTAL PAID = \$254.66



General Information: 714-741-5307

CITY OF GARDEN GROVE - DEVELOPMENT SERVICES DEPARTMENT

Inspection Requests: 714-741-5332

PERMIT (PAGE 2 of 2)

PROJECT/SITE/BUILDING DESCRIPTION

JOB Address : 13916 BROOKHURST ST
 Suite : D
 PERMIT NO. : 34214
 Permit Type : SIGN
 Type : B11
 SIGNS
 Owner : CHOE, KYONG SUN
 Applicant : CUSTOM TECH DESIGN
 Appl Address : 15201 WESTSTATE
 WESTMINSTER, CA 92683
 Phone : 891-7796

Insp Dist : SB
 Date : 07/17/96
 Parcel No : 09934413

PROPOSED WORK:

2 WALL SIGNS 20SF EA.

FEEES

Plan Check	1	104.00
Permit	1	160.00
Issuance	1	25.00
Strong Motion Fee (Com)	1	
General Plan	1	10.72
Cultural Arts	1	5.28

INSPECTION RECORD

APPROVAL	DATE	INSPECTOR
Pre Inspect	_____	_____
Foundation	_____	_____
Concrete Floor	_____	_____
Reinforcing	_____	_____
Masonry	_____	_____
Roof Shtg	_____	_____
Rough Frame	_____	_____
Insul / Energy	_____	_____
Drywall	_____	_____
Lath	_____	_____
Plas. Brown Ct.	_____	_____
Landscaping	_____	_____
Pre Gunite	_____	_____
Pre Deck	_____	_____
Pre Plaster	_____	_____
Planning Final	_____	_____
Bldg Final	_____	_____
Utility Notified	_____	_____

11 3226 BLDG PERM &	160.00
11 3251 STRONG MOTIO	0.00
11 3517 ISSUANCE FEE	25.00
11 3527 BLDG P C FEE	104.00
80 3224 PERMITS/CULT	5.28
92 2163 GENERAL PLAN	10.72
TOTAL	305.00

AUTHORIZATION

Issued By: janetw Date _____

DECLARATION

I certify that I have read this application/permit and state that the information on all pages of this document is correct. I agree to comply with all City and County ordinances and State laws relating to building construction, and hereby authorize representatives of this City and County to enter upon the above mentioned property for inspection purposes.

Applicant's Signature [Signature]
 Print Name TOM VINN Date 7/17/96

***** VALIDATION *****
 PAID ON 17 Jul 1996 AT 15:08
 RECEIVED BY AMANDAB station1/2 TRANS# 122
 PAID BY CHECK#5792 FOR \$305.00
 TOTAL PAID = \$305.00

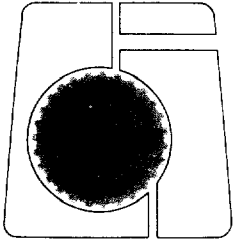

CITY OF GARDEN GROVE, CALIFORNIA

DEVELOPMENT SERVICES DEPARTMENT/CODE ENFORCEMENT SECTION

SIGN FIELD CHECK

PLEASE COMPLETE TOP HALF AND SUBMIT WITH PERMIT APPLICATION.

PERMIT # 34214

APPLICATION DATE 7/17/96

GARDEN GROVE

SITE ADDRESS: 13916 #D Brookhurst

BUSINESS NAME: Saigon Fabrics

PERSON TO CONTACT: Tom Vinh PHONE: 714 891-7796

CONTRACTOR: " " (Custom Tech Design) PHONE: _____

BUSINESS OWNER: Do Tuan Ngoc PHONE: 5306778

COPIES OF THE FOLLOWING SHALL BE SUBMITTED WITH EACH APPLICATION:

- BUILDING PERMIT: (form provided by the City) *not required for painted on wall sign*
- PLOT PLAN: Show Dimensions, setbacks, existing signs, proposed signs, existing buildings. (form provided by the city)
- ELEVATIONS: Two (2) copies showing existing and proposed sign locations.
- DETAILED DRAWINGS: Two (2) scaled drawings showing colors, materials, mounting method, copy and dimensions of proposed sign(s).
- ELECTRICAL PERMIT: Required for illuminated signs.

Please allow 3 to 5 days processing time for sign approval.

DEPARTMENT USE ONLY

ZONE: C-2 PRIMARY SECONDARY SPECIFIC SIGN CRITERIA

Building frontage 18 feet (x2.5 for single channel letters)

Lot frontage _____

Allowable area 45 ~~35~~ # _____

EXISTING SIGNS		PROPOSED SIGNS		APPROVED
TYPE	AREA	TYPE	AREA	
1. _____	_____	2. Wall signs	20 sqft	<input checked="" type="checkbox"/>
2. _____	_____	3. _____	2	DATE: <u>7.16.96</u>
3. _____	_____	4. _____	40 #	
4. _____	_____	5. _____	_____	
TOTAL _____		TOTAL <u>40 #</u>		
COMBINED TOTAL _____		BY: <u>[Signature]</u>		

Comments, Conditions, Recommendations: _____

CITY OF GARDEN GROVE - DEVELOPMENT SERVICES DEPARTMENT - PLOT PLAN FORM

Planning action:	Use zone: <i>C-2</i>
Land use approved by: <i>KH/11</i>	Lot size:
Date: <i>7/15/96</i>	Lot coverage:
Remarks: <i>2 Wall signs only 20 ft</i>	& increase

Job address: <i>13916 4D Brookhurst</i>	Permit No: <i>34214</i>		
Assessor Parcel No: <i>09934413</i>	Legal desc.:		
Occupancy:	Const. type:	Sprinklers:	Value:
<input checked="" type="checkbox"/> New	<input type="checkbox"/> Alter	<input type="checkbox"/> Add	<input type="checkbox"/> Repair <input type="checkbox"/> Demo

Job Description: *WALL SIGNAGE channel letters*

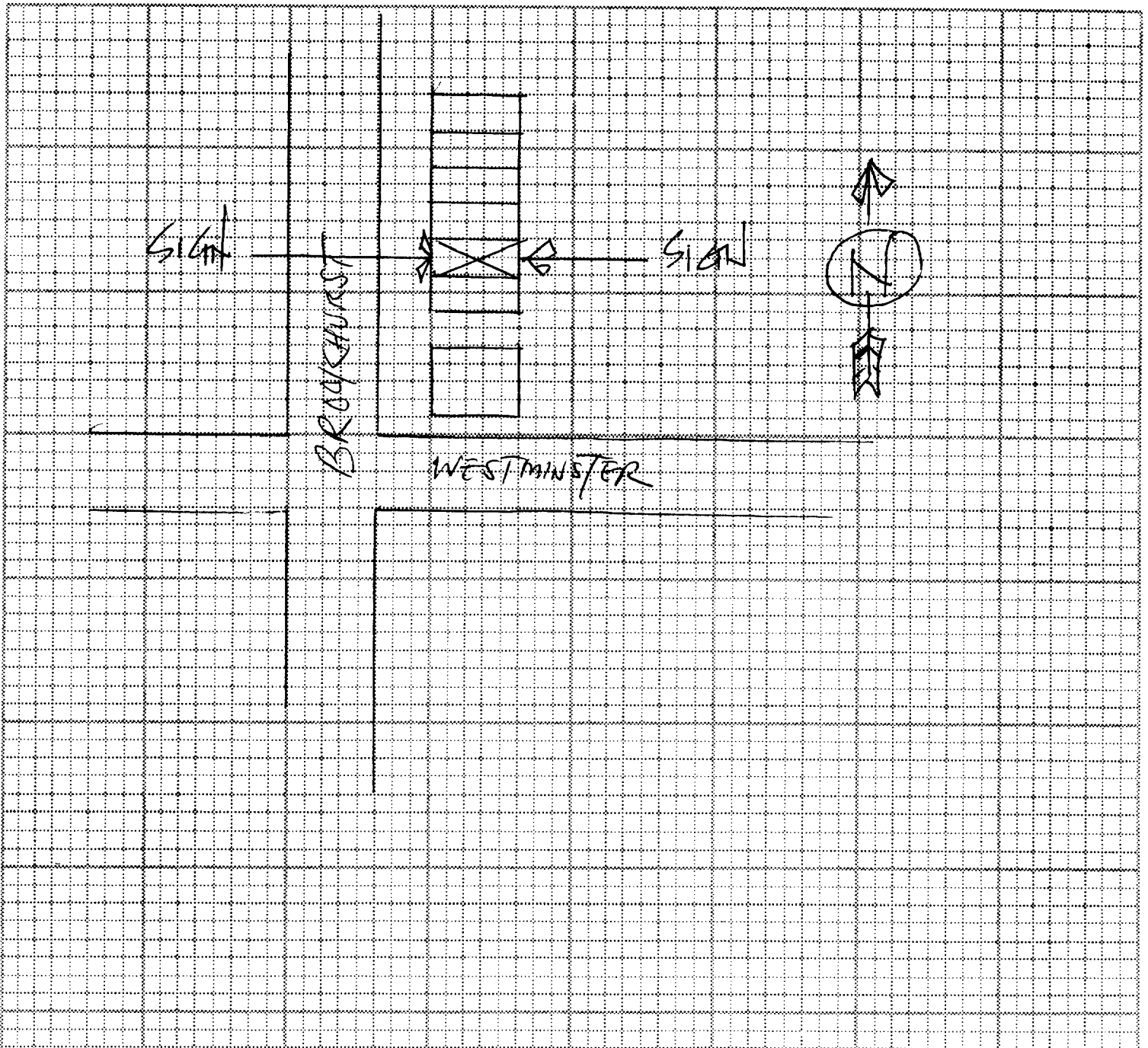

White: Inspection
 Yellow: Assessor
 Pink: Permittee

I certify the information hereon is complete & correct.

Owner's name (print) _____ Signature (owner/agent) _____ Date _____



PERMIT (PAGE 2 of 2)

PROJECT/SITE/BUILDING DESCRIPTION

JOB Address : 13916 BROOKHURST ST
 Suite : F
 PERMIT NO. : 36565
 Permit Type : SIGN
 Type : B11
 SIGNS
 Owner : CHOE, KYONG SUN
 Applicant : T T SIGNS
 Appl Address : 15177 MORAN ST
 WESTMINSTER, CA 92683
 Phone : 714 373-4840

PROPOSED WORK:

ONE WALL SIGN

Insp Dist : SB
 Date : 01/23/97
 Parcel No : 09934413

FEES

Plan Check	1	53.30
Permit	1	82.00
Issuance	1	30.00
General Plan	1	11.86
Cultural Arts	1	5.86

INSPECTION RECORD

APPROVAL	DATE	INSPECTOR
----------	------	-----------

Pre Inspect _____
 Foundation _____
 Concrete Floor _____
 Reinforcing _____
 Masonry _____
 Roof Shtg _____
 Rough Frame _____
 Insul / Energy _____
 Drywall _____
 Lath _____
 Plas.Brown Ct. _____
 Landscaping _____
 Pre Gunite _____
 Pre Deck _____
 Pre Plaster _____

11 3226 BLDG PERMIT	82.00
11 3517 ISSUANCE FEE	30.00
11 3527 BLDG P C FEE	53.30
80 3224 PERMITS/CULT	5.86
92 2163 GENERAL PLAN	11.86

TOTAL 183.02

Planning Final **EXPIRED**

Bldg Final 1-2-98 109

Utility Notified _____

AUTHORIZATION

Issued By: janetw Date _____

DECLARATION

I certify that I have read this application/permit and state that the information on all pages of this document is correct. I agree to comply with all City and County ordinances and State laws relating to building construction, and hereby authorize representatives of this City and County to enter upon the above mentioned property for inspection purposes.

Applicant's Signature Thanh Mai

Print Name THANH MAI Date 1-23-97

***** VALIDATION *****
 PAID ON 23 Jan 1997 AT 16:29
 RECEIVED BY DOXIE station1/2 TRANS# 132
 PAID BY CHECK#1671 FOR \$241.02
 TOTAL PAID = \$241.02



PERMIT (PAGE 2 of 2)

PROJECT/SITE/BUILDING DESCRIPTION

JOB Address : 13916 BROOKHURST ST
 Suite : F
 PERMIT NO. : 36566
 Permit Type :
 Type : E
 Owner : CHOE, KYONG SUN
 Applicant : T T SIGNS
 Appl Address : 15177 MORAN ST
 WESTMINSTER, CA 92683
 Phone : 714 373-4840
 Insp Dist : SE
 Date : 01/23/97
 Parcel No : 09934413

PROPOSED WORK:

SIGN HOOKUP

FEEES

SIGN HOOKUP	1	21.00
Issuance	1	30.00
GENERAL PLAN	1	2.00
CULTURAL ARTS	1	1.00
MINIMUM ELECTRICAL FEE	1	4.00

INSPECTION RECORD

APPROVAL DATE INSPECTOR

Underground _____
 Conduit _____
 Wiring - Rough _____
 Heater _____
 Fixtures & Trim _____
 Motors _____
 Ufer _____
 Service _____

11 3227 ELECTRICAL P	25.00
11 3517 ISSUANCE FEE	30.00
80 3224 PERMITS/CULT	1.00
92 2163 GENERAL PLAN	2.00

TOTAL 58.00

AUTHORIZATION

Issued By: janetw Date _____

DECLARATION

I certify that I have read this application/permit and state that the information on all pages of this document is correct. I agree to comply with all City and County ordinances and State laws relating to building construction, and hereby authorize representatives of this City and County to enter upon the above mentioned property for inspection purposes.

Applicant's Signature Thanh Mai

Print Name THANH MAI Date 1-23-97

FINAL _____

Utility Notified 1-23-97 JAL

***** VALIDATION *****
 PAID ON 23 Jan 1997 AT 16:29
 RECEIVED BY DOXIE station 1/2 TRANS# 132
 PAID BY CHECK#1671 FOR \$241.02
 TOTAL PAID = \$241.02

CITY OF GARDEN GROVE - DEVELOPMENT SERVICES DEPARTMENT - PLOT PLAN FORM

Planning action:		Use zone: <u>C-1</u>
Land use approved by: <u>SA</u>	Date: <u>1/23/97</u>	Lot size:
Remarks:		Lot coverage:
		% increase

Job address: <u>13916 BROOKHURST, #F</u>	Permit No.:			
Assessor Parcel No.:	Legal desc.:			
Occupancy:	Const. type:	Sprinklers:	Value: <u>900.00</u>	
<input checked="" type="checkbox"/> New	<input type="checkbox"/> Alter	<input type="checkbox"/> Add	<input type="checkbox"/> Repair	<input type="checkbox"/> Demo

Job Description: Illuminated wall sign

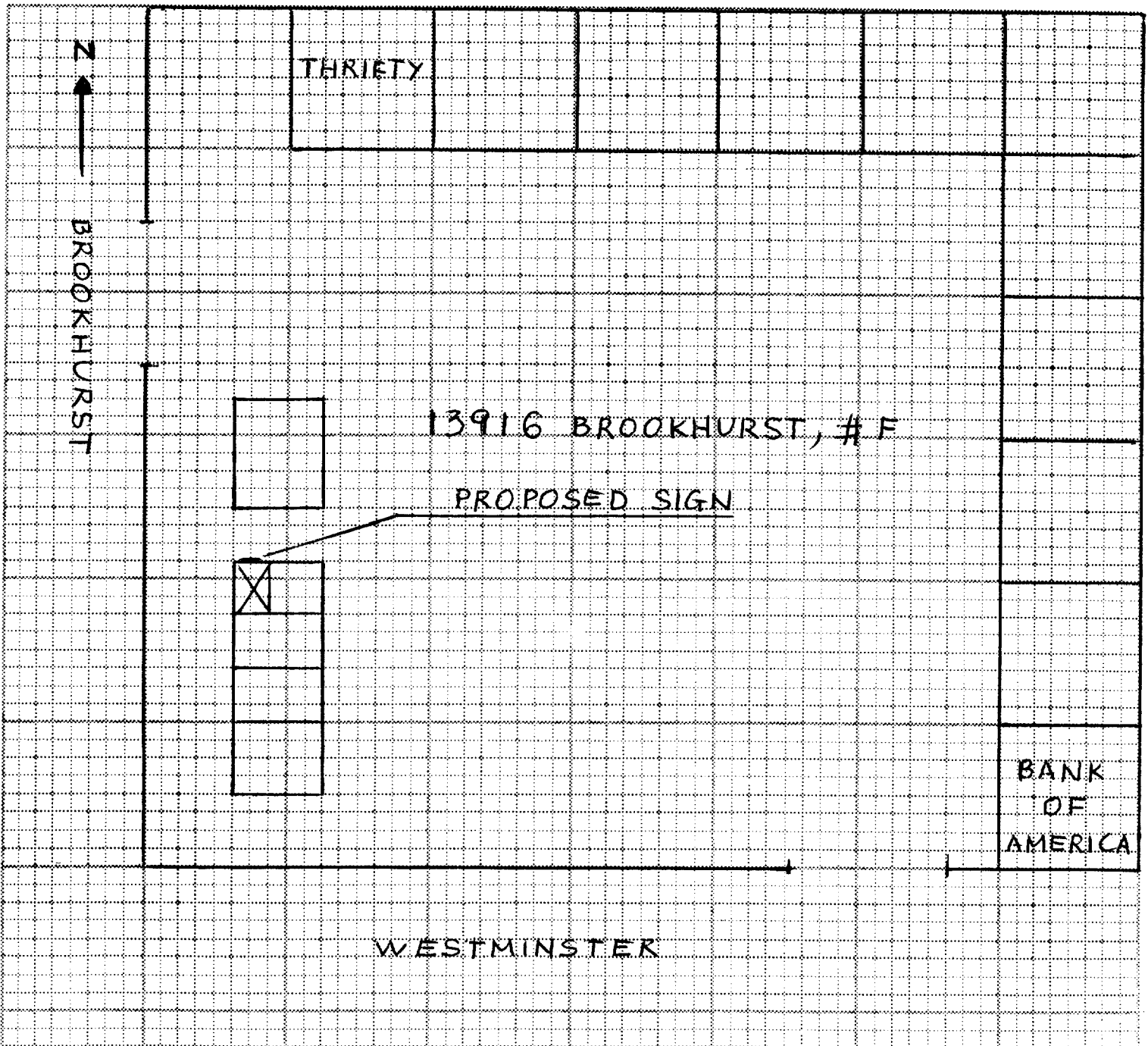

White: Inspection
 Yellow: Assessor
 Pink: Permittee

I certify the information hereon is complete & correct.
THANH NAM Thanh Nam 1-23-97
 Owner's name (print) Signature (owner/agent) Date

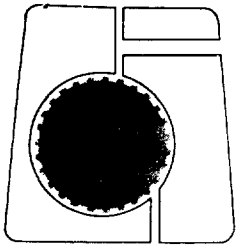

CITY OF GARDEN GROVE, CALIFORNIA

DEVELOPMENT SERVICES DEPARTMENT/CODE ENFORCEMENT SECTION

SIGN FIELD CHECK

PLEASE COMPLETE TOP HALF AND SUBMIT WITH PERMIT APPLICATION.

PERMIT # _____

APPLICATION DATE 1-23-97

SITE ADDRESS: 13916 - F BROOKHURST ST, GARDEN GROVE, CA

BUSINESS NAME: PAYLESS CIGARETTES & CIGARS

PERSON TO CONTACT: KIM MAI PHONE: 373-4840

CONTRACTOR: TT SIGNS PHONE: 373-4840

BUSINESS OWNER: WINSTON K. CHOE PHONE: 539-3500

- COPIES OF THE FOLLOWING SHALL BE SUBMITTED WITH EACH APPLICATION:
- BUILDING PERMIT: (form provided by the City) *not required for painted on wall sign*
 - PLOT PLAN: Show Dimensions, setbacks, existing signs, proposed signs, existing buildings. (form provided by the city)
 - ELEVATIONS: Two (2) copies showing existing and proposed sign locations.
 - DETAILED DRAWINGS: Two (2) scaled drawings showing colors, materials, mounting method, copy and dimensions of proposed sign(s).
 - ELECTRICAL PERMIT: Required for illuminated signs.

Please allow 3 to 5 days processing time for sign approval.

DEPARTMENT USE ONLY

ZONE: <u>G1</u>	PRIMARY	SECONDARY	SPECIFIC SIGN CRITERIA <input checked="" type="checkbox"/>
Building frontage	<u>21</u>	_____	_____
Lot frontage	_____	_____	_____
Allowable area	<u>50</u>	_____	_____

EXISTING SIGNS		PROPOSED SIGNS		APPROVED <input checked="" type="checkbox"/>	DENIED <input type="checkbox"/>
TYPE	AREA	TYPE	AREA		
1. _____	_____	5. <u>Wall Sign</u>	<u>15.75 x 2.3</u>	DATE: <u>1/23/97</u>	
2. _____	_____	6. _____	<u>37 SF</u>		
3. _____	_____	7. _____	_____		
4. _____	_____	8. _____	_____		
TOTAL <u>37 SF</u>		TOTAL <u>37 SF</u>			
COMBINED TOTAL _____		BY: _____			

Comments, Conditions, Recommendations: _____

CITY OF GARDEN GROVE - DEVELOPMENT SERVICES DEPARTMENT - PLOT PLAN FORM

Planning action:	Use zone:
Land use approved by:	Date:
Remarks:	Lot size:
	Lot coverage:
	& increase

Job address: 13916 BROOKHURST, # F	Permit No.:		
Assessor Parcel No.:	Legal desc.:		
Occupancy:	Const. type:	Sprinklers:	Value: 900.00
<input checked="" type="checkbox"/> New	<input type="checkbox"/> Alter	<input type="checkbox"/> Add	<input type="checkbox"/> Repair <input type="checkbox"/> Demo

Job Description: *Illuminated wall sign*

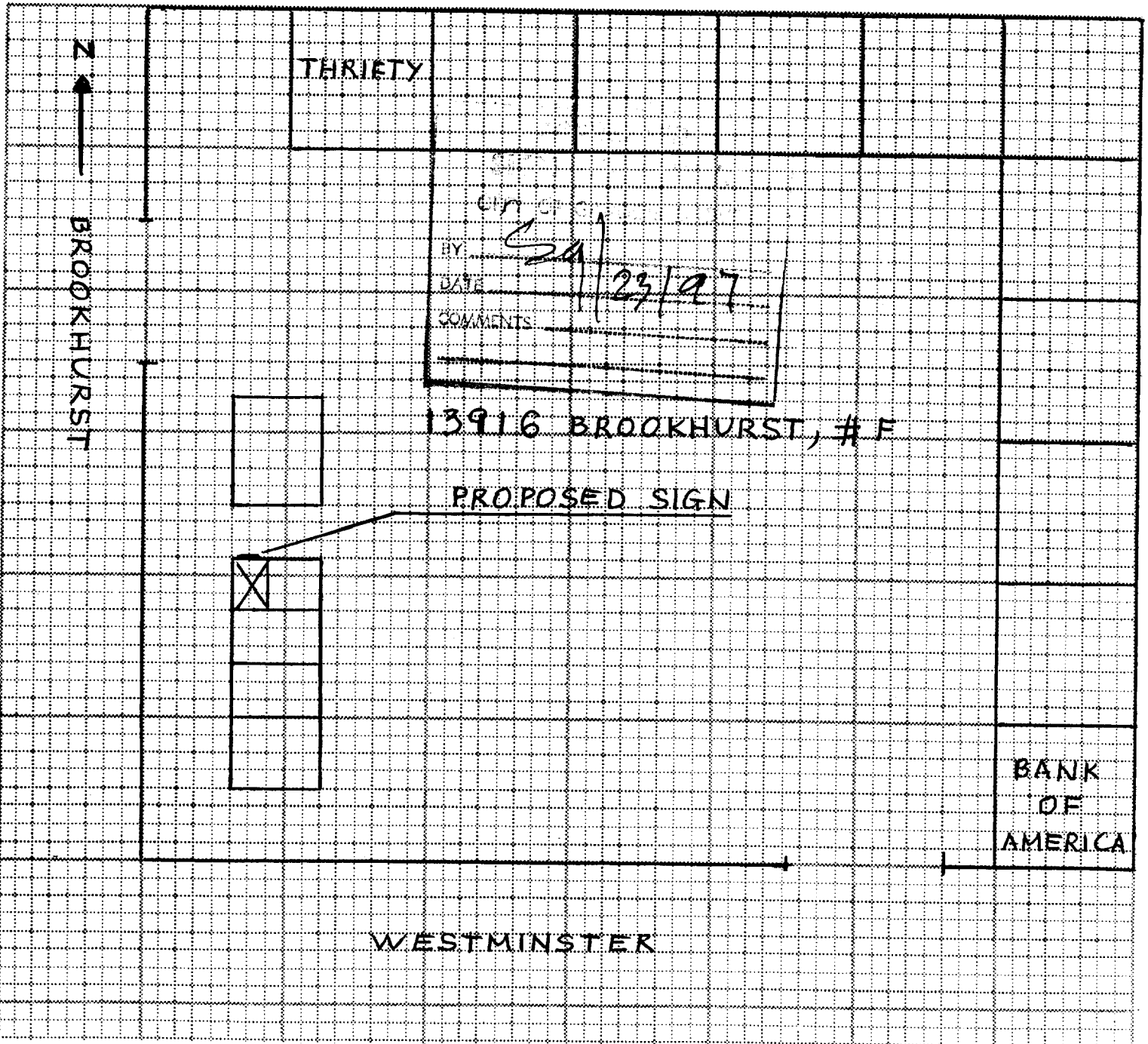

White: Inspection
 Yellow: Assessor
 Pink: Permittee

I certify the information hereon is complete & correct.
THANH MA Owner's name (print) Thanh Ma Signature (owner/agent) 1-23-97 Date

13916 BROOKHURST ST, # F, GARDEN GROVE, CA 92643

CHANNE

Landlord's approval Winston Choe

Date 1-23-97

GARDEN GROVE SHOPPING PLAZA
13872 Brookhurst St.
Garden Grove, CA 92643
(714) 537-6424

APPROVED
SIGN CODE PER
CITY OF GARDEN GROVE

BY [Signature]

DATE 1/23/97

COMMENTS _____

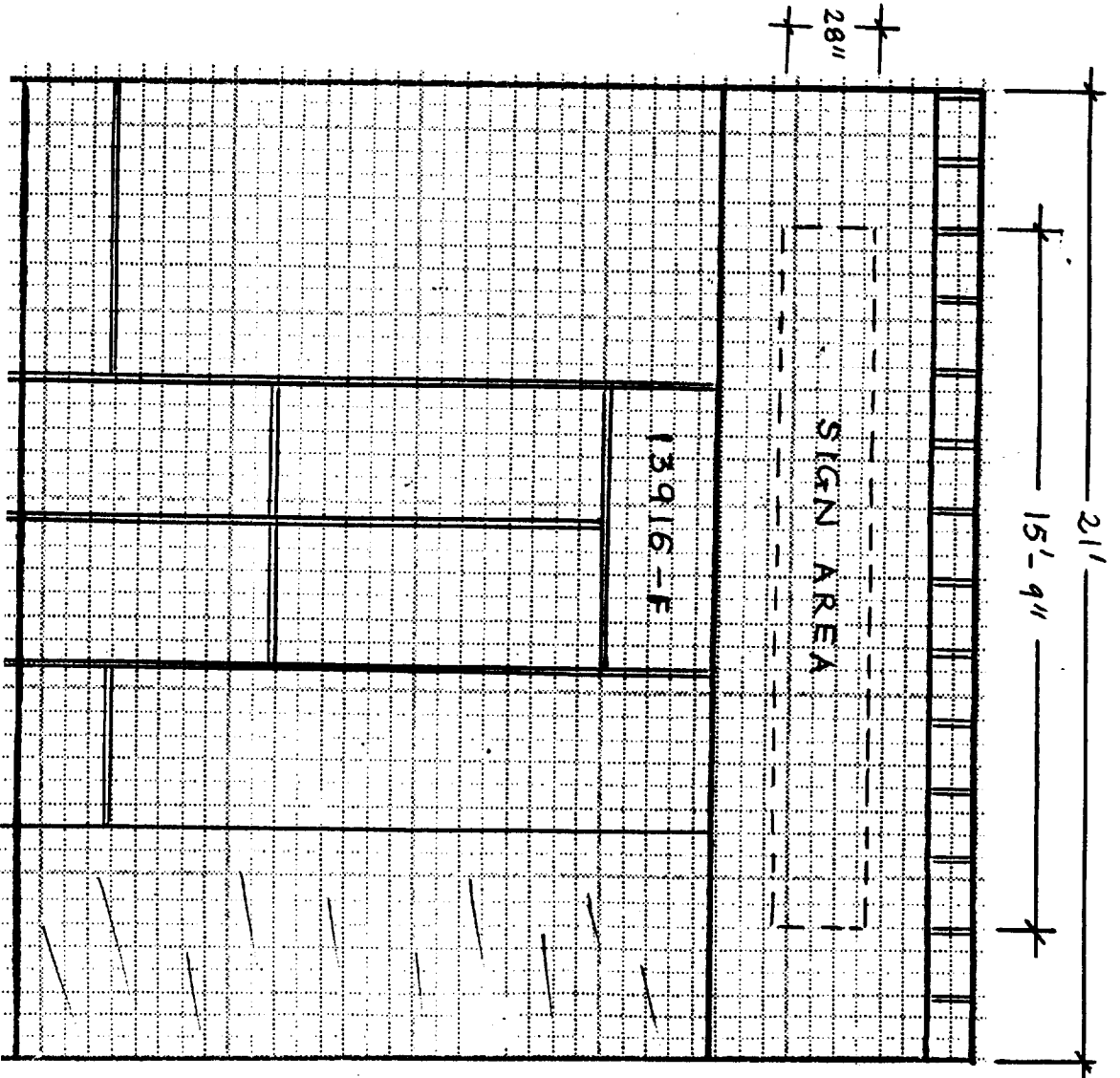

28" 8" 14" 15'-9" 28"

PAYLESS
CIGARETTES & CIGARS

- 1)
- 2)
- 3)
- 4)
- 5)
- 6)
- 7)
- 8) 2-
- 9)
- 10)



General Information: 714-741-5307

CITY OF GARDEN GROVE - DEVELOPMENT SERVICES DEPARTMENT

Inspection Requests: 714-741-5332

PERMIT (PAGE 2 of 2)

PROJECT/SITE/BUILDING DESCRIPTION

JOB Address : 13916 BROOKHURST ST
 Suite : 3
 PERMIT NO. : 32981
 Permit Type :
 Type : P

Owner : CHOE, KYONG SUN
 Applicant : ACREAGE CONSTRUCTION CO.
 Appl Address : 1020 MICHELLE CT.
 MONTEBELLO, CA 90640
 Phone : 213 721-3927

Insp Dist : ZP
 Date : 04/22/96
 Parcel No : 09934413

PROPOSED WORK:

FLOOR SINK/SUPPLEMENT TO #32149

FEEES

Floor Sink	1	8.00
------------	---	------

INSPECTION RECORD

APPROVAL	DATE	INSPECTOR
----------	------	-----------

Soil Piping _____
 Ground Plumbing _____
 Rough Plumbing _____
 Gas Piping _____
 Gas Vent _____
 Sewer _____
 Main Drain _____
 Vacuum Lines _____
 Water Heater _____
 Backwash _____
 Water Lateral _____

11 3228 PLUMBING PER 8.00

TOTAL 8.00

EXPIRED

EXPIRED

8-25-97

Utility Notified _____

AUTHORIZATION

Issued By: janetw Date _____

DECLARATION

I certify that I have read this application/permit and state that the information on all pages of this document is correct. I agree to comply with all City and County ordinances and State laws relating to building construction, and hereby authorize representatives of this City and County to enter upon the above mentioned property for inspection purposes.

Applicant's Signature [Signature]

Print Name Sam Shin Date 4/22/96

***** VALIDATION *****
 PAID ON 22 Apr 1996 AT 09:05
 RECEIVED BY TERESAP station1/2 TRANS# 15
 PAID BY CHECK#2144 FOR \$9.60
 TOTAL PAID = \$9.60



General Information: 714-741-5307

CITY OF GARDEN GROVE - DEVELOPMENT SERVICES DEPARTMENT

Inspection Requests: 714-741-5332

PERMIT (PAGE 2 of 2)

PROJECT/SITE/BUILDING DESCRIPTION

JOB Address : 13916 BROOKHURST ST
Suite :
PERMIT NO. : 33131
Permit Type :
Type : P

Owner : CHOE, KYONG SUN
Applicant : OWNER
Appl Address : 13916 BROOKHURST ST

Phone :

Insp Dist : ZP
Date : 05/02/96
Parcel No : 09934413

PROPOSED WORK:

FLOOR SINK SUPPLEMENT TO 32981

FEEES

BACKFLOW PROT DEV 2" MAX	1	8.00
Water Piping (ea. 100')	1	8.00

INSPECTION RECORD

APPROVAL	DATE	INSPECTOR
Soil Piping	_____	_____
Ground Plumbing	_____	_____
Rough Plumbing	_____	_____
Gas Piping	_____	_____
Gas Vent	_____	_____
Sewer	_____	_____
Main Drain	_____	_____
Vacuum Lines	_____	_____
Water Heater	_____	_____
Backwash	_____	_____
Water Lateral	_____	_____

11 3228 PLUMBING PER 16.00

TOTAL 16.00

EXPIRED

8-25-97 *[Signature]*
Utility Notified _____

AUTHORIZATION

Issued By: janetw Date _____

DECLARATION

I certify that I have read this application/permit and state that the information on all pages of this document is correct. I agree to comply with all City and County ordinances and State laws relating to building construction, and hereby authorize representatives of this City and County to enter upon the above mentioned property for inspection purposes.

Applicant's Signature *[Signature]*

Print Name Sam Shin Date 5/2/96

***** VALIDATION *****
 PAID ON 02 May 1996 AT 15:49
 RECEIVED BY TERESAP station 1/2 TRANS# 108
 CASH PAID = \$20.00 CASH RETURNED = \$4.00
 TOTAL PAID = \$16.00



General Information: 714-741-5307

CITY OF GARDEN GROVE - DEVELOPMENT SERVICES DEPARTMENT

Inspection Requests: 714-741-5332

PERMIT (PAGE 2 of 2)

PROJECT/SITE/BUILDING DESCRIPTION

JOB Address : 13916 BROOKHURST ST
 Suite :
 PERMIT NO. : 33077
 Permit Type :
 Type : P
 Owner : CHOE, KYONG SUN
 Applicant : ACREAGE CONSTRUCTION CO.
 Appl Address : 1020 MICHELLE CT.
 MONTEBELLO, CA 90640
 Phone : 213 721-3927
 Insp Dist : ZP
 Date : 04/29/96
 Parcel No : 09934413

PROPOSED WORK:

PLBG FOR T.I.

FEES

WATER CLOSET, BIDET	1	8.00
Lavatory	1	8.00
Issuance	1	25.00
GENERAL PLAN	1	2.00
CULTURAL ARTS	1	1.00
MINIMUM PLUMBING FEE	1	4.00

INSPECTION RECORD

APPROVAL	DATE	INSPECTOR
Soil Piping		
Ground Plumbing		
Rough Plumbing		
Gas Piping		
Gas Vent		
Sewer		
Main Drain		
Vacuum Lines		
Water Heater		
Backwash		
Water Lateral		

11 3228 PLUMBING PER	20.00
11 3517 ISSUANCE FEE	25.00
80 3224 PERMITS/CULT	1.00
92 2163 GENERAL PLAN	2.00
TOTAL	48.00

EXPIRED

Handwritten: 8-25-97 *AS*
 Utility Notified _____

AUTHORIZATION

Issued By: jmc Date _____

DECLARATION

I certify that I have read this application/permit and state that the information on all pages of this document is correct. I agree to comply with all City and County ordinances and State laws relating to building construction, and hereby authorize representatives of this City and County to enter upon the above mentioned property for inspection purposes.

Applicant's Signature *Sam Shin*
 Print Name Sam Shin Date 4/29/96

***** VALIDATION *****
 PAID ON 29 Apr 1996 AT 12:40
 RECEIVED BY TERESAP station1/2 TRANS# 72
 PAID BY CHECK#2156 FOR \$224.35
 TOTAL PAID = \$224.35



General Information: 714-741-5307

CITY OF GARDEN GROVE - DEVELOPMENT SERVICES DEPARTMENT

Inspection Requests: 714-741-5332

PERMIT (PAGE 2 of 2)

PROJECT/SITE/BUILDING DESCRIPTION

JOB Address : 13916 BROOKHURST ST
 Suite : A THRU F
 PERMIT NO. : 7326M
 Permit Type : BUILDING
 Type : B21
 MISCELLANEOUS
 Owner : CHOE, KYONG SUN
 Applicant : OWNER
 Appl Address : 13916 BROOKHURST ST

Phone :

Insp Dist : ZB
 Date : 04/02/96
 Parcel No : 09934413

PROPOSED WORK:

CHANGE SUITE NUMBERS

FEEES

SUPPLEMENTAL PLAN CHECK	1	50.00
-------------------------	---	-------

INSPECTION RECORD

APPROVAL	DATE	INSPECTOR
----------	------	-----------

Pre Inspect _____
 Foundation _____
 Concrete Floor _____
 Reinforcing _____
 Masonry _____
 Roof Shtg _____
 Rough Frame _____
 Insul / Energy _____
 Drywall _____
 Lath _____
 Plas. Brown Ct. _____
 Landscaping _____
 Pre Gunite _____
 Pre Deck _____
 Pre Plaster _____

11 3527 BLDG P C FEE 50.00

TOTAL 50.00

Planning Final _____

EXPIRED

Signature 8.25.97

Utility Notified _____

AUTHORIZATION

Issued By: dingv Date _____

DECLARATION

I certify that I have read this application/permit and state that the information on all pages of this document is correct. I agree to comply with all City and County ordinances and State laws relating to building construction, and hereby authorize representatives of this City and County to enter upon the above mentioned property for inspection purposes.

Applicant's Signature _____

Print Name _____ Date _____

***** VALIDATION *****
 PAID ON 02 Apr 1996 AT 14:08
 RECEIVED BY JULIAA station1/2 TRANS# 90
 CASH PAID = \$100.00 CASH RETURNED = \$0.00
 TOTAL PAID = \$100.00



General Information: 714-741-5307

CITY OF GARDEN GROVE - DEVELOPMENT SERVICES DEPARTMENT

Inspection Requests: 714-741-5332

PERMIT (PAGE 2 of 2)

PROJECT/SITE/BUILDING DESCRIPTION

JOB Address : 12181 BROOKHURST ST
 Suite :
 PERMIT NO. : 38230
 Permit Type :
 Type : E
 Owner : ITT FED BANK
 Applicant : FREEDOM FIREWORKS, INC.
 Appl Address : 14111 FREEWAY DR. #200
 SANTA FE SPRINGS, CA 90670
 Phone : 310 921-1466

PROPOSED WORK:

FIREWORKS STAND BNAI BRITH COVENANT LODGE

FEEES

Insp Dist	: ZE	Outlets 1-20	1	.80
Date	: 06/02/97	Fixtures 1-20	2	1.60
Parcel No	: 13311124	GENERATOR, 10 KW MAX	1	9.00
		GENERAL PLAN	1	2.00
		CULTURAL ARTS	1	1.00
		MINIMUM ELECTRICAL FEE	1	13.60
		Issuance	1	30.00

INSPECTION RECORD

APPROVAL DATE INSPECTOR
 Underground _____
 Conduit _____
 Wiring - Rough _____
 Heater _____
 Fixtures & Trim _____
 Motors _____
 Ufer _____
 Service _____

11 3227 ELECTRICAL P 25.00
 11 3517 ISSUANCE FEE 30.00
 80 3224 PERMITS/CULT 1.00
 92 2163 GENERAL PLAN 2.00

TOTAL 58.00

AUTHORIZATION

Issued By: cherylv Date _____

DECLARATION

I certify that I have read this application/permit and state that the information on all pages of this document is correct. I agree to comply with all City and County ordinances and State laws relating to building construction, and hereby authorize representatives of this City and County to enter upon the above mentioned property for inspection purposes.

Applicant's Signature _____
 Print Name MARK GREEN Date 6/3/97

FINAL 7-7-97
 Utility Notified _____

***** VALIDATION *****
 PAID ON 03 Jun 1997 AT 14:47
 RECEIVED BY DOXIE 198.245.206.11/2 TRANS# 159
 PAID BY CHECK#43784 FOR \$58.00
 TOTAL PAID = \$58.00



General Information: 714-741-5307

CITY OF GARDEN GROVE - DEVELOPMENT SERVICES DEPARTMENT

Inspection Requests: 714-741-5332

PERMIT (PAGE 2 of 2)

PROJECT/SITE/BUILDING DESCRIPTION

JOB Address : 13916 BROOKHURST ST
 Suite : ~~#2~~ "F"
 PERMIT NO. : 32137
 Permit Type : BUILDING
 Type : B7
 ALTERATIONS TO OTHER BUILDINGS
 Owner : CHOE, KYONG SUN
 Applicant : ACREAGE CONSTRUCTION CO.
 Appl Address : 1020 MICHELLE CT.
 MONTEBELLO, CA 90640
 Phone : 213 721-3927

Insp Dist : ZB
 Date : 02/13/96
 Parcel No : 09934413

PROPOSED WORK:

DEMISING WALLS, ADD RESTROOM & T-BAR CEILING.

FEES

Plan Check	1	64.68
Permit	1	100.00
Issuance	1	25.00
PLN.RET.LTR.SIZE	3	3.00
Pln.Ret.Lgr.Size	5	7.50
General Plan	1	9.55
Cultural Arts	1	4.70
PLAN CHECK FEE CREDIT	1	-64.68

INSPECTION RECORD

APPROVAL	DATE	INSPECTOR
Pre Inspect	_____	_____
Foundation	_____	_____
Concrete Floor	_____	_____
Reinforcing	_____	_____
Masonry	_____	_____
Roof Shtg	_____	_____
Rough Frame	_____	_____
Insul / Energy	_____	_____
Drywall	_____	_____
Lath	_____	_____
Plas.Brown Ct.	_____	_____
Landscaping	_____	_____
Pre Gunite	_____	_____
Pre Deck	_____	_____
Pre Plaster	_____	_____
Planning Final	_____	_____
Bldg Final	2/12/96	[Signature]
Utility Notified	_____	_____

11 3226 BLDG PERM &	100.00
11 3517 ISSUANCE FEE	25.00
11 3527 BLDG P C FEE	0.00
11 3542 PLAN RETENTI	10.50
80 3224 PERMITS/CULT	4.70
92 2163 GENERAL PLAN	9.55
TOTAL	149.75

AUTHORIZATION

Issued By: jimc _____ Date _____

DECLARATION

I certify that I have read this application/permit and state that the information on all pages of this document is correct. I agree to comply with all City and County ordinances and State laws relating to building construction, and hereby authorize representatives of this City and County to enter upon the above mentioned property for inspection purposes.

Applicant's Signature _____

Print Name _____ Date _____

***** VALIDATION *****
 PAID ON 13 Feb 1996 AT 17:30
 RECEIVED BY NANCYM station1/2 TRANS# 150
 PAID BY CHECK#2004 FOR \$1496.40
 TOTAL PAID = \$1496.40

CITY OF GARDEN GROVE - DEVELOPMENT SERVICES DEPARTMENT - PLOT PLAN FORM

Planning action:	Use zone:
Land use approved by:	Date:
Remarks:	Lot size:
	Lot coverage:
	% increase

Job address: 13916-F BROOKHURST AVE.		Permit No. 32745
Assessor Parcel No. 09034413		Legal desc.:
Occupancy:	Const. type:	Sprinklers:
Value: 6500.00		
<input type="checkbox"/> New <input checked="" type="checkbox"/> Alter <input type="checkbox"/> Add <input type="checkbox"/> Repair <input type="checkbox"/> Demo		

Job Description: TENANT IMPROVEMENT / SUB-DIVISION
 (ADD DEMISING WALLS TO CREATE 8 SEPARATE SUITES).

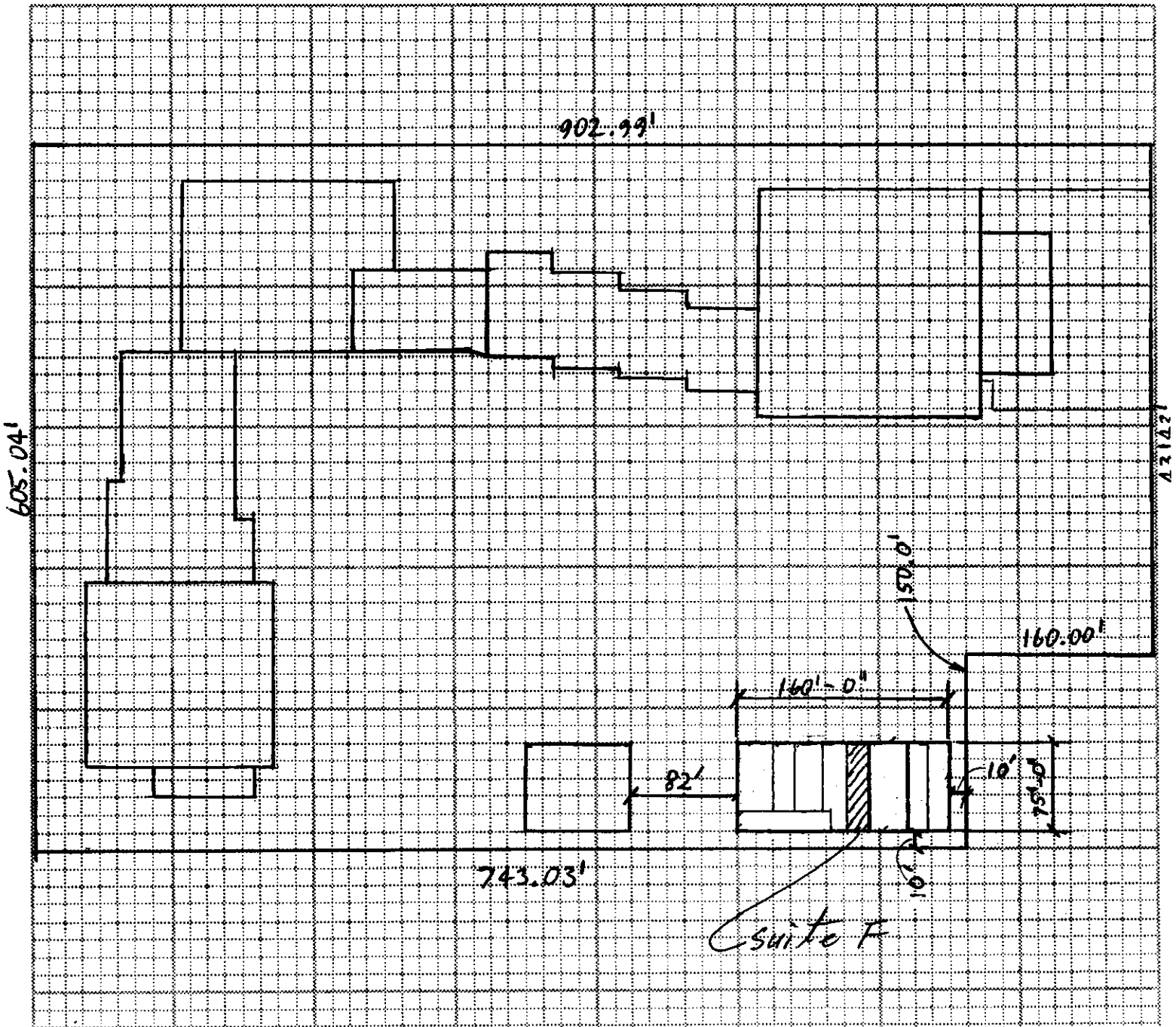

White: Inspection
 Yellow: Assessor
 Pink: Permittee

I certify the information hereon is complete & correct.
WINSTON CHOE [Signature] 2/12/96
 Owner's name (print) Signature (owner/agent) Date



General Information: 714-741-5307

CITY OF GARDEN GROVE - DEVELOPMENT SERVICES DEPARTMENT

Inspection Requests: 714-741-5332

PERMIT (PAGE 2 of 2)

PROJECT/SITE/BUILDING DESCRIPTION

JOB Address : 13916 BROOKHURST ST
 Suite : # "E"
 PERMIT NO. : 32145
 Permit Type : BUILDING
 Type : B7
 ALTERATIONS TO OTHER BUILDINGS
 Owner : CHOE, KYONG SUN
 Applicant : ACREAGE CONSTRUCTION CO.
 Appl Address : 1020 MICHELLE CT.
 MONTEBELLO, CA 90640
 Phone : 213 721-3927

Insp Dist : ZB
 Date : 02/13/96
 Parcel No : 09934413

PROPOSED WORK:

DEMISING WALLS & T-BAR CEILING.

FEES

Permit	1	100.00
Issuance	1	25.00
PLN.RET.LTR.SIZE	1	1.00
General Plan	1	9.55
Cultural Arts	1	4.70

INSPECTION RECORD

APPROVAL	DATE	INSPECTOR
Pre Inspect		
Foundation		
Concrete Floor		
Reinforcing		
Masonry		
Roof Shtg		
Rough Frame		
Insul / Energy		
Drywall		
Lath		
Plas.Brown Ct.		
Landscaping		
Pre Gunite		
Pre Deck		
Pre Plaster		
Planning Final		
Bldg Final		
Utility Notified		

11 3226 BLDG PERM &	100.00
11 3517 ISSUANCE FEE	25.00
11 3542 PLAN RETENTI	1.00
80 3224 PERMITS/CULT	4.70
92 2163 GENERAL PLAN	9.55

TOTAL 140.25

AUTHORIZATION

Issued By: jimc _____ Date _____

DECLARATION

I certify that I have read this application/permit and state that the information on all pages of this document is correct. I agree to comply with all City and County ordinances and State laws relating to building construction, and hereby authorize representatives of this City and County to enter upon the above mentioned property for inspection purposes.

Applicant's Signature _____

Print Name _____ Date _____

***** VALIDATION *****
 PAID ON 13 Feb 1996 AT 17:30
 RECEIVED BY NANCYM station1/2 TRANS# 150
 PAID BY CHECK#2004 FOR \$1496.40
 TOTAL PAID = \$1496.40

CITY OF GARDEN GROVE - DEVELOPMENT SERVICES DEPARTMENT - PLOT PLAN FORM

Planning action:	Use zone:
Land use approved by:	Date:
Remarks:	Lot size:
	Lot coverage:
	% increase

Job address: 13916 - E BROOKHURST AVE.	Permit No. 32142			
Assessor Parcel No. 00134413	Legal desc.:			
Occupancy:	Const. type:	Sprinklers:	Value: 6500.00	
<input type="checkbox"/> New	<input checked="" type="checkbox"/> Alter	<input type="checkbox"/> Add	<input type="checkbox"/> Repair	<input type="checkbox"/> Demo

Job Description: TENANT IMPROVEMENT / SUB-DIVISION
 (ADD DEMISING WALLS TO CREATE 8 SEPARATE SUITES).

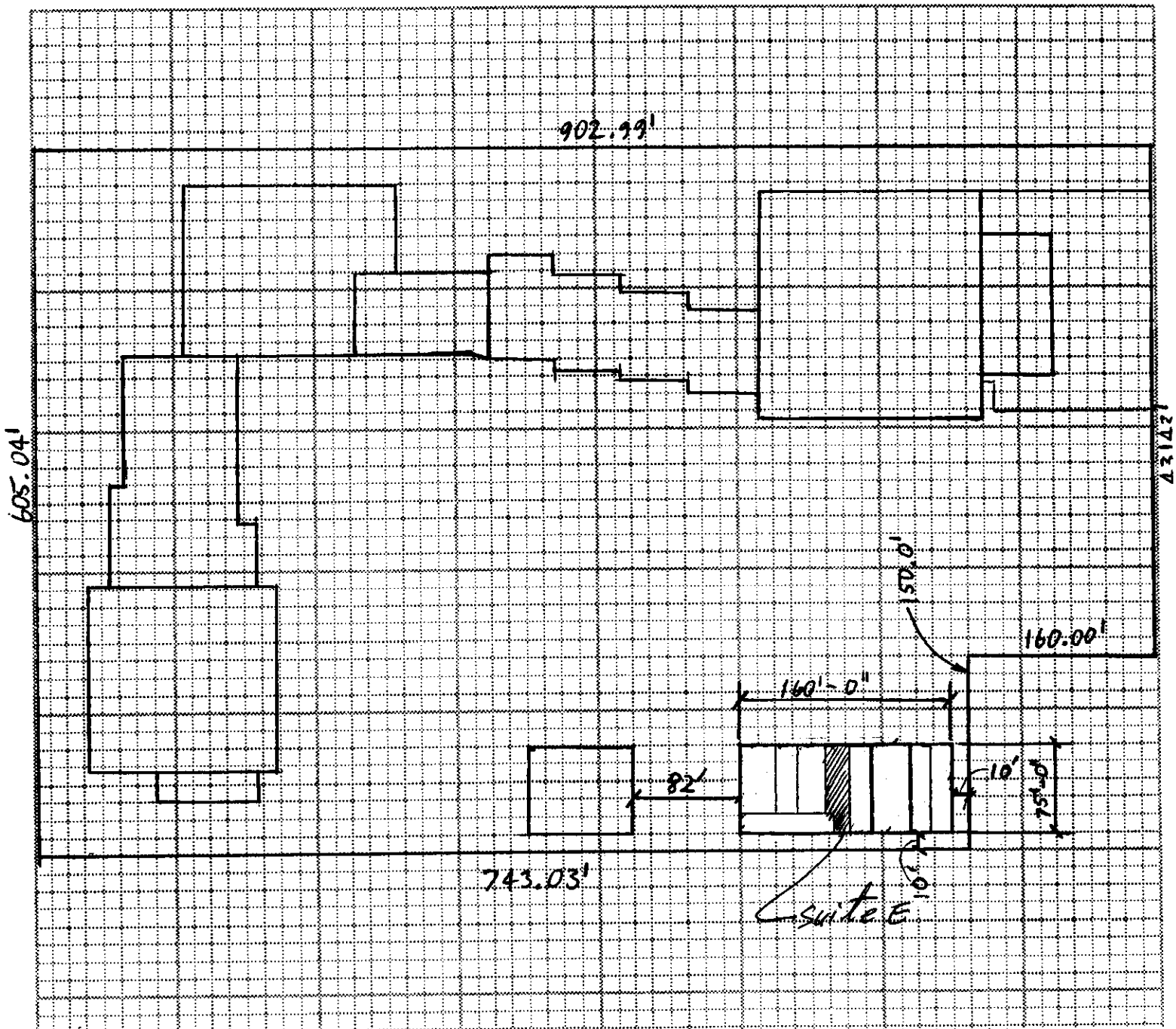

White: Inspection
 Yellow: Assessor
 Pink: Permittee

I certify the information hereon is complete & correct.
WINSTON CHOE
 Owner's name (print) Signature (owner/agent) Date 2/12/96



PERMIT (PAGE 2 of 2)

PROJECT/SITE/BUILDING DESCRIPTION

JOB Address : 13916 BROOKHURST ST
 Suite : ~~139~~ "D"
 PERMIT NO. : 32142
 Permit Type : BUILDING
 Type : B7
 ALTERATIONS TO OTHER BUILDINGS
 Owner : CHOE, KYONG SUN
 Applicant : ACREAGE CONSTRUCTION CO.
 Appl Address : 1020 MICHELLE CT.
 MONTEBELLO, CA 90640
 Phone : 213 721-3927

Insp Dist : ZB
 Date : 02/13/96
 Parcel No : 09934413

PROPOSED WORK:

DIMISING WALLS, ADD RESTROOM & T-BAR CEILING.

FEES

Permit	1	100.00
Issuance	1	25.00
PLN.RET.LTR.SIZE	1	1.00
General Plan	1	9.55
Cultural Arts	1	4.70

INSPECTION RECORD

APPROVAL	DATE	INSPECTOR
Pre Inspect		
Foundation		
Concrete Floor		
Reinforcing		
Masonry		
Roof Shtg		
Rough Frame		
Insul / Energy		
Drywall		
Lath		
Plas.Brown Ct.		
Landscaping		
Pre Gunite		
Pre Deck		
Pre Plaster		
Planning Final		
Bldg Final	7/2/96	
Utility Notified		

11 3226 BLDG PERM &	100.00
11 3517 ISSUANCE FEE	25.00
11 3542 PLAN RETENTI	1.00
80 3224 PERMITS/CULT	4.70
92 2163 GENERAL PLAN	9.55
TOTAL	140.25

AUTHORIZATION

Issued By: jimc _____ Date _____

DECLARATION

I certify that I have read this application/permit and state that the information on all pages of this document is correct. I agree to comply with all City and County ordinances and State laws relating to building construction, and hereby authorize representatives of this City and County to enter upon the above mentioned property for inspection purposes.

Applicant's Signature _____

Print Name _____ Date _____

***** VALIDATION *****
 PAID ON 13 Feb 1996 AT 17:30
 RECEIVED BY NANCYM station1/2 TRANS# 150
 PAID BY CHECK#2004 FOR \$1496.40
 TOTAL PAID = \$1496.40

CITY OF GARDEN GROVE - DEVELOPMENT SERVICES DEPARTMENT - PLOT PLAN FORM

Planning action:	Use zone:
Land use approved by:	Lot size:
Date:	Lot coverage:
Remarks:	± increase

Job address: 13916-D BROOKHURST AVE.	Permit No. 2740		
Assessor Parcel No. 09934413	Legal desc.:		
Occupancy:	Const. type:	Sprinklers:	Value: 6500 ⁰⁰
<input type="checkbox"/> New	<input checked="" type="checkbox"/> Alter	<input type="checkbox"/> Add	<input type="checkbox"/> Repair <input type="checkbox"/> Demo

Job Description: TENANT IMPROVEMENT / SUB-DIVISION
(ADD DEMISING WALLS TO CREATE 8 SEPARATE SUITES).

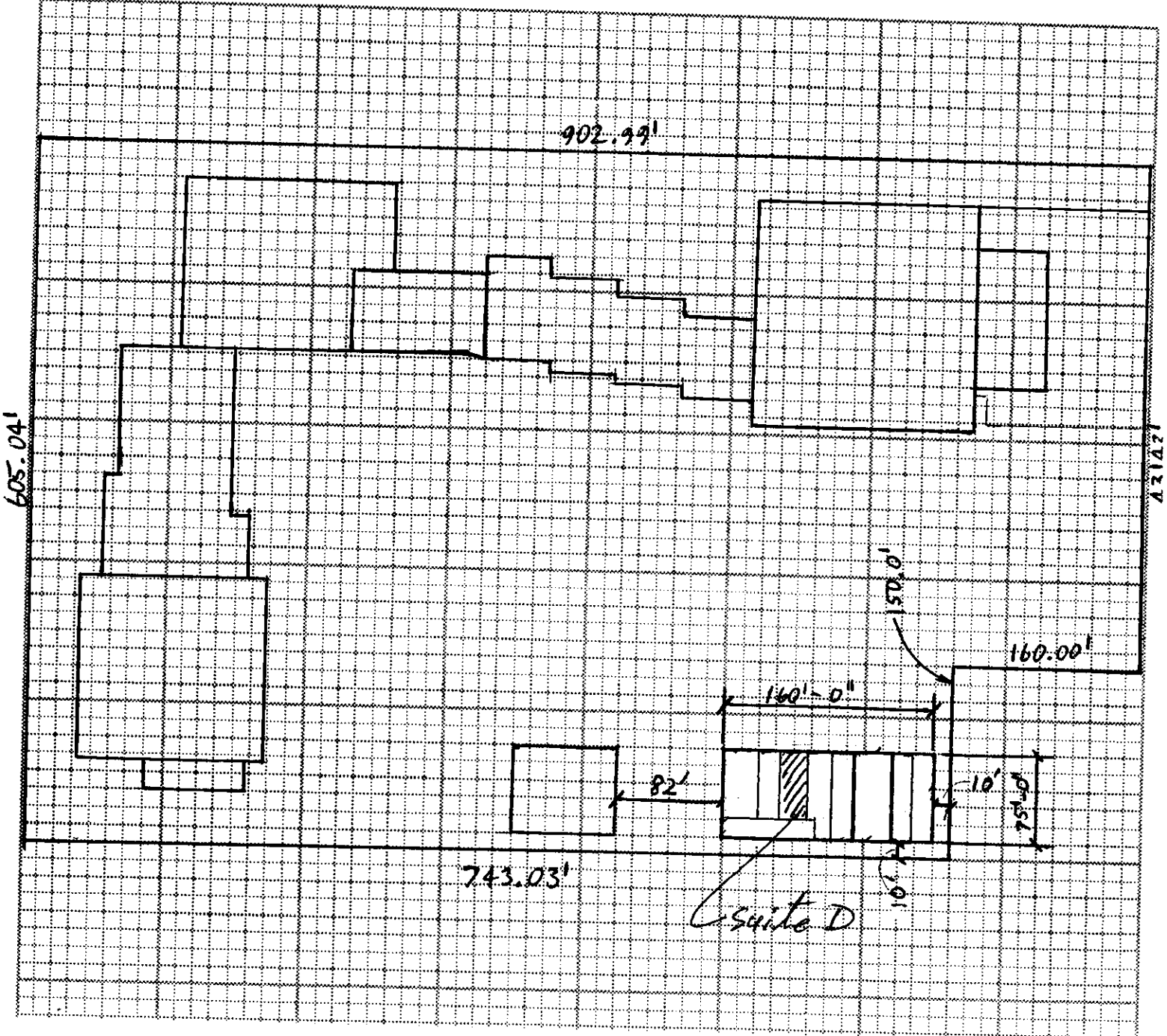

White: Inspection
Yellow: Assessor
Pink: Permittee

I certify the information hereon is complete & correct.
 Owner's name (print) WINSTON CHOE
 Signature (owner/agent) [Signature]
 Date 2/12/96



General Information: 714-741-5307

CITY OF GARDEN GROVE - DEVELOPMENT SERVICES DEPARTMENT

Inspection Requests: 714-741-5332

PERMIT (PAGE 2 of 2)

PROJECT/SITE/BUILDING DESCRIPTION

JOB Address : 13916 BROOKHURST ST
 Suite : ~~#B~~ "C"
 PERMIT NO. : 32140
 Permit Type : BUILDING
 Type : B7
 ALTERATIONS TO OTHER BUILDINGS
 Owner : CHOE, KYONG SUN
 Applicant : ACREAGE CONSTRUCTION CO.
 Appl Address : 1020 MICHELLE CT.
 MONTEBELLO, CA 90640
 Phone : 213 721-3927

Insp Dist : ZB
 Date : 02/13/96
 Parcel No : 09934413

PROPOSED WORK:

DIMISING WALLS, ADD RESTROOM & T-BAR CEILING.

FEES

Permit	1	100.00
Issuance	1	25.00
PLN.RET.LTR.SIZE	1	1.00
General Plan	1	9.55
Cultural Arts	1	4.70

INSPECTION RECORD

APPROVAL	DATE	INSPECTOR
Pre Inspect		
Foundation		
Concrete Floor		
Reinforcing		
Masonry		
Roof Shtg		
Rough Frame		
Insul / Energy		
Drywall		
Lath		
Plas.Brown Ct.		
Landscaping		
Pre Gunite		
Pre Deck		
Pre Plaster		
Planning Final		
Bldg Final	2/13/96	[Signature]
Utility Notified		

11 3226 BLDG PERM &	100.00
11 3517 ISSUANCE FEE	25.00
11 3542 PLAN RETENTI	1.00
80 3224 PERMITS/CULT	4.70
92 2163 GENERAL PLAN	9.55

TOTAL 140.25

AUTHORIZATION

Issued By: jimc Date

DECLARATION

I certify that I have read this application/permit and state that the information on all pages of this document is correct. I agree to comply with all City and County ordinances and State laws relating to building construction, and hereby authorize representatives of this City and County to enter upon the above mentioned property for inspection purposes.

Applicant's Signature

Print Name Date

***** VALIDATION *****
 PAID ON 13 Feb 1996 AT 17:30
 RECEIVED BY NANCYM station1/2 TRANS# 150
 PAID BY CHECK#2004 FOR \$1496.40
 TOTAL PAID = \$1496.40

CITY OF GARDEN GROVE - DEVELOPMENT SERVICES DEPARTMENT - PLOT PLAN FORM

Planning action:	Use zone:
Land use approved by:	Date:
Remarks:	Lot size:
	Lot coverage:
	% increase

Job address: 13916-C BROOKMURST AVE	Permit No. 32139		
Assessor Parcel No. 09934413	Legal desc.:		
Occupancy:	Const. type:	Sprinklers:	Value: 6500 ⁰⁰
<input type="checkbox"/> New	<input checked="" type="checkbox"/> Alter	<input type="checkbox"/> Add	<input type="checkbox"/> Repair <input type="checkbox"/> Demo

Job Description: TENANT IMPROVEMENT / SUB-DIVISION
(ADD DEMISING WALLS TO CREATE 8 SEPARATE SUITES).

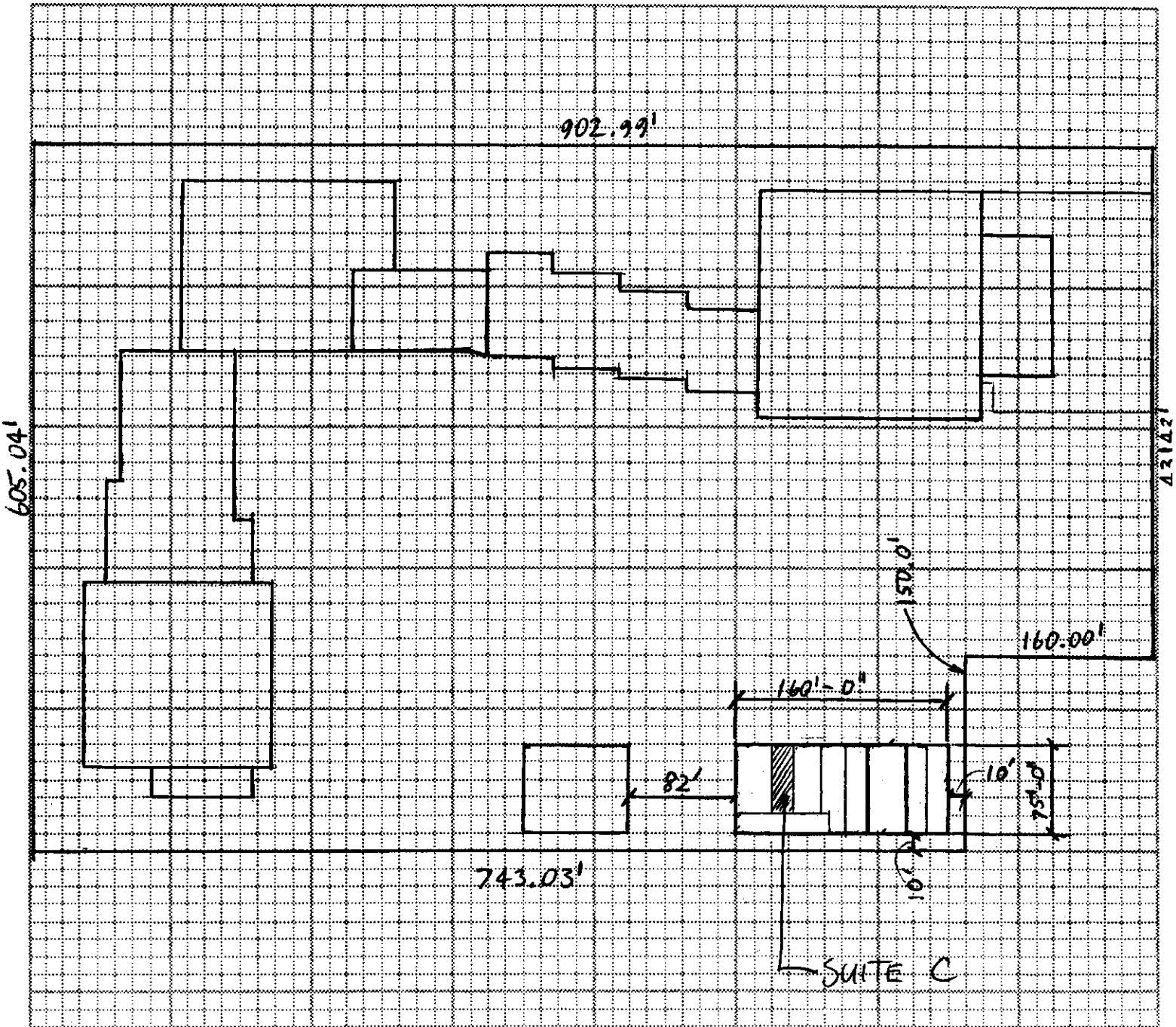

White: Inspection
Yellow: Assessor
Pink: Permittee

I certify the information hereon is complete & correct.
WINSTON CHOE [Signature] 2/12/96
 Owner's name (print) Signature (owner/agent) Date



General Information: 714-741-5307

CITY OF GARDEN GROVE - DEVELOPMENT SERVICES DEPARTMENT

Inspection Requests: 714-741-5332

PERMIT (PAGE 2 of 2)

PROJECT/SITE/BUILDING DESCRIPTION

JOB Address : 13916 BROOKHURST ST
 Suite : ~~#~~ "B"
 PERMIT NO. : 32139
 Permit Type : BUILDING
 Type : B7
 ALTERATIONS TO OTHER BUILDINGS
 Owner : CHOE, KYONG SUN
 Applicant : ACREAGE CONSTRUCTION CO.
 Appl Address : 1020 MICHELLE CT.
 MONTEBELLO, CA 90640
 Phone : 213 721-3927

Insp Dist : ZB
 Date : 02/13/96
 Parcel No : 09934413

PROPOSED WORK:

DEMISING WALLS, ADD RESTROOM & T-BAR CEILING.

FEES

Plan Check	1	64.68
Permit	1	100.00
Issuance	1	25.00
PLN.RET.LTR.SIZE	1	1.00
General Plan	1	9.55
Cultural Arts	1	4.70
PLAN CHECK FEE CREDIT	1	-64.68

INSPECTION RECORD

APPROVAL	DATE	INSPECTOR
Pre Inspect		
Foundation		
Concrete Floor		
Reinforcing		
Masonry		
Roof Shtg		
Rough Frame		
Insul / Energy		
Drywall		
Lath		
Plas.Brown Ct.		
Landscaping		
Pre Gunite		
Pre Deck		
Pre Plaster		
Planning Final		
Bldg Final	7.17.96	[Signature]
Utility Notified		

11 3226 BLDG PERM &	100.00
11 3517 ISSUANCE FEE	25.00
11 3527 BLDG P C FEE	0.00
11 3542 PLAN RETENTI	1.00
80 3224 PERMITS/CULT	4.70
92 2163 GENERAL PLAN	9.55
TOTAL	140.25

AUTHORIZATION

Issued By: jimc _____ Date _____

DECLARATION

I certify that I have read this application/permit and state that the information on all pages of this document is correct. I agree to comply with all City and County ordinances and State laws relating to building construction, and hereby authorize representatives of this City and County to enter upon the above mentioned property for inspection purposes.

Applicant's Signature _____

Print Name _____ Date _____

***** VALIDATION *****
 PAID ON 13 Feb 1996 AT 17:30
 RECEIVED BY NANCYM station1/2 TRANS# 150
 PAID BY CHECK#2004 FOR \$1496.40
 TOTAL PAID = \$1496.40

CITY OF GARDEN GROVE - DEVELOPMENT SERVICES DEPARTMENT - PLOT PLAN FORM

Planning action:	Use zone:
Land use approved by:	Date:
Remarks:	Lot size:
	Lot coverage:
	% increase

Job address: 13916-B BROOKHURST AVE.		Permit No. 32138
Assessor Parcel No. 09934413		Legal desc.:
Occupancy:	Const. type:	Sprinklers:
		Value: 6500 ⁰⁰
<input type="checkbox"/> New <input checked="" type="checkbox"/> Alter <input type="checkbox"/> Add <input type="checkbox"/> Repair <input type="checkbox"/> Demo		

Job Description: TENANT IMPROVEMENT / SUB-DIVISION
 (ADD DEMISING WALLS TO CREATE 8 SEPARATE SUITES).

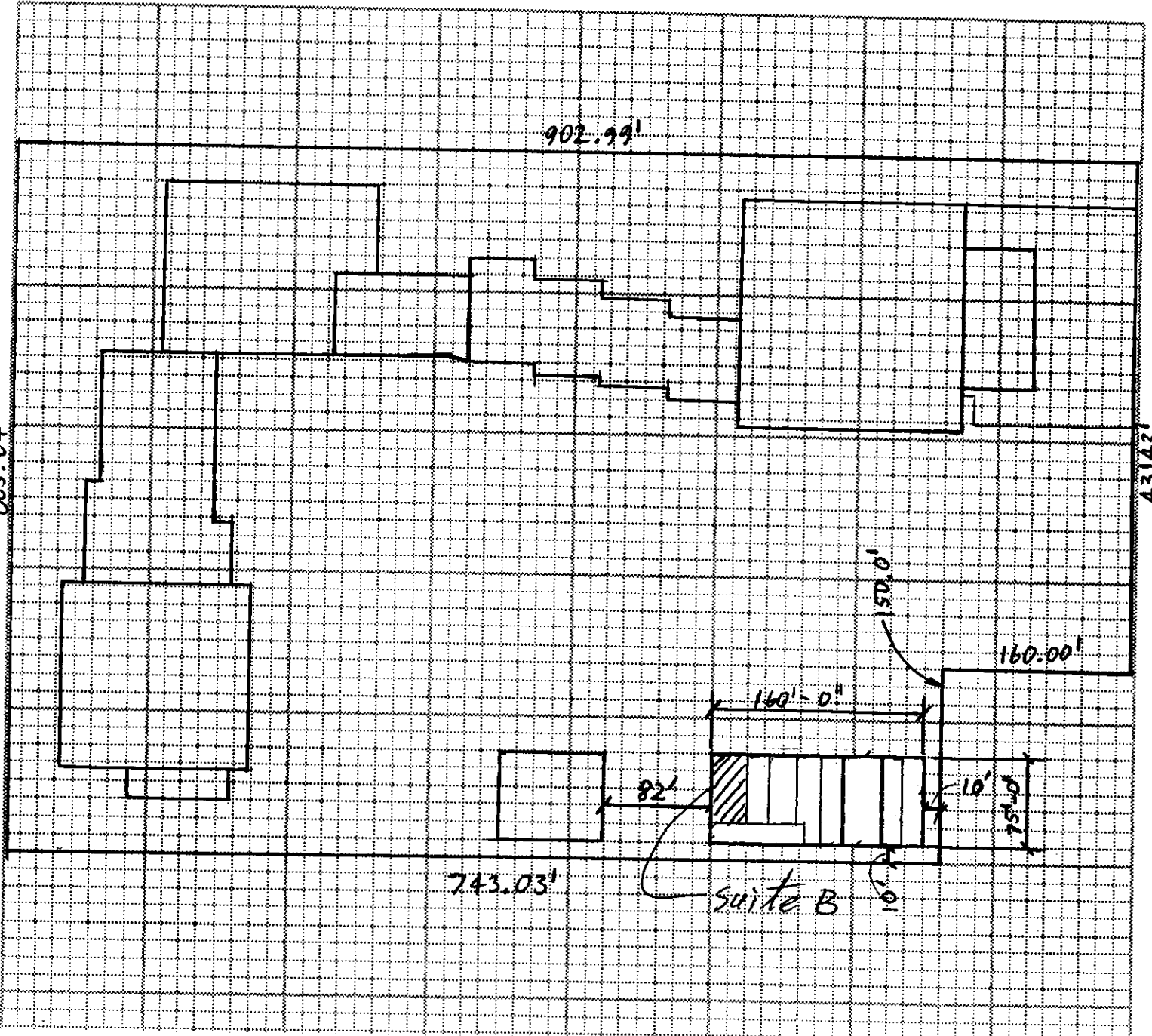

White: Inspection
 Yellow: Assessor
 Pink: Permittee

I certify the information hereon is complete & correct.
 WINSTON CHOE
 Owner's name (print) Signature (owner/agent) Date 2/12/96



General Information: 714-741-5307

CITY OF GARDEN GROVE - DEVELOPMENT SERVICES DEPARTMENT

Inspection Requests: 714-741-5332

PERMIT (PAGE 2 of 2)

PROJECT/SITE/BUILDING DESCRIPTION

JOB Address : 13916 BROOKHURST ST
 Suite :
 PERMIT NO. : 33805
 Permit Type :
 Type : H
 Owner : CHOE, KYONG SUN
 Applicant : CENTRAL TECH CO
 Appl Address : 14915 WATKINS DR
 LA MIRADA, CA 90638
 Phone : 523-4542
 Insp Dist : ZH
 Date : 06/20/96
 Parcel No : 09934413

PROPOSED WORK:

INSTALL (2) AC UNITS ON ROOF. PLAN CHECK # M
 1088
 (UNITS FOR B+C ONLY)

FEES

REPAIR, ALTR COOL/HEAT SYS	1	10.00
BOILER/COMPRESSOR TO 3 HP	2	20.00
Plan Check	1	19.50
PLAN CHECK FEE CREDIT	1	-13.00
Issuance	1	25.00
GENERAL PLAN	1	2.00
CULTURAL ARTS	1	1.00

INSPECTION RECORD

APPROVAL	DATE	INSPECTOR
Furnace		
Furnace Vents		
Gas Piping		
Ducts		
Duct Fan Vent		
Kitchen Hood		
Air Handl Unit		
Evap Cooler		
Boiler Comp		
Decor Appl		

11 3229 HEATING PERM	30.00
11 3517 ISSUANCE FEE	25.00
11 3523 HEATING P C	19.50
11 3527 BLDG P C FEE	0.00
80 3224 PERMITS/CULT	1.00
92 2163 GENERAL PLAN	2.00

TOTAL 64.50

AUTHORIZATION

Issued By: jimc Date

DECLARATION

I certify that I have read this application/permit and state that the information on all pages of this document is correct. I agree to comply with all City and County ordinances and State laws relating to building construction, and hereby authorize representatives of this City and County to enter upon the above mentioned property for inspection purposes.

Applicant's Signature [Signature]
 Print Name Han K Kim Date 6/20/96

FINAL 7/2/96 D. Forder

Utility Notified

***** VALIDATION *****
 PAID ON 20 Jun 1996 AT 07:23
 RECEIVED BY TERESAP station 1/2 TRANS# 4
 PAID BY CHECK#5019 FOR \$64.50
 TOTAL PAID = \$64.50



General Information: 714-741-5307

CITY OF GARDEN GROVE - DEVELOPMENT SERVICES DEPARTMENT

Inspection Requests: 714-741-5332

PERMIT (PAGE 2 of 2)

PROJECT/SITE/BUILDING DESCRIPTION

JOB Address : 13916 BROOKHURST ST
 Suite : 13916-13920
 PERMIT NO. : 33404
 Permit Type :
 Type : E

 Owner : CHOE, KYONG SUN
 Applicant : AMCO ELECTRIC
 Appl Address : 19432 E SPRINGPORT DR
 ROWLAND HEIGHTS, CA 91748
 Phone : 9095954538

 Insp Dist : ZE
 Date : 05/29/96
 Parcel No : 09934413

PROPOSED WORK:

REVISION OF MAIN SWBD SUBJECT TO FIELD INSPECTION.

FEES

Service Over 200 Amp	1	40.00
Plan Check	1	26.00
PLAN CHECK FEE CREDIT	1	-26.00
Issuance	1	25.00
GENERAL PLAN	1	2.00
CULTURAL ARTS	1	1.00

INSPECTION RECORD

APPROVAL	DATE	INSPECTOR
Underground	_____	_____
Conduit	_____	_____
Wiring - Rough	_____	_____
Heater	_____	_____
Fixtures & Trim	_____	_____
Motors	_____	_____
Ufer	_____	_____
Service	_____	_____
_____	_____	_____
_____	_____	_____
_____	_____	_____

11 3227 ELECTRICAL P	40.00
11 3517 ISSUANCE FEE	25.00
11 3524 ELECTRICAL P	26.00
11 3527 BLDG P C FEE	0.00
80 3224 PERMITS/CULT	1.00
92 2163 GENERAL PLAN	2.00
TOTAL	68.00

EXPIRED

5-6-97 *[Signature]*

FINAL _____
 Utility Notified _____

AUTHORIZATION

Issued By: jimc _____ Date _____

DECLARATION

I certify that I have read this application/permit and state that the information on all pages of this document is correct. I agree to comply with all City and County ordinances and State laws relating to building construction, and hereby authorize representatives of this City and County to enter upon the above mentioned property for inspection purposes.

Applicant's Signature *[Signature]*
 Print Name Seung T. Kim Date 5/29/96

***** VALIDATION *****
 PAID ON 29 May 1996 AT 07:43
 RECEIVED BY DOXIE station 1/2 TRANS# 7
 PAID BY CHECK#2202 FOR \$68.00
 TOTAL PAID = \$68.00



General Information: 714-741-5307

CITY OF GARDEN GROVE - DEVELOPMENT SERVICES DEPARTMENT

Inspection Requests: 714-741-5332

PERMIT (PAGE 2 of 2)

PROJECT/SITE/BUILDING DESCRIPTION

JOB Address : 13916 BROOKHURST ST
 Suite : A
 PERMIT NO. : 33075
 Permit Type : BUILDING
 Type : B7
 ALTERATIONS TO OTHER BUILDINGS
 Owner : CHOE, KYONG SUN
 Applicant : OWNER
 Appl Address : 13916 BROOKHURST ST

Phone :

Insp Dist : ZB
 Date : 04/29/96
 Parcel No : 09934413

PROPOSED WORK:

INTERIOR PARTITIONS & NEW HANDICAP RESTROOMS FOR RETAIL SPACE.

FEES

Plan Check	1	51.74
Permit	1	80.10
Issuance	1	25.00
PLN.RET.LTR.SIZE	2	2.00
Pln.Ret.Lgr.Size	7	10.50
General Plan	1	7.20
Cultural Arts	1	3.55
PLAN CHECK FEE CREDIT	1	-51.74

INSPECTION RECORD

APPROVAL	DATE	INSPECTOR
Pre Inspect		
Foundation		
Concrete Floor		
Reinforcing		
Masonry		
Roof Shtg		
Rough Frame	4/10/96	[Signature]
Insul / Energy		
Drywall	4/23/96	[Signature]
Lath		
Plas.Brown Ct.		
Landscaping		
Pre Gunite		
Pre Deck		
Pre Plaster		
Planning Final		
Bldg Final	7/2/96	[Signature]
Utility Notified		

11 3226 BLDG PERM &	80.10
11 3517 ISSUANCE FEE	25.00
11 3527 BLDG P C FEE	0.00
11 3542 PLAN RETENTI	12.50
80 3224 PERMITS/CULT	3.55
92 2163 GENERAL PLAN	7.20
TOTAL	128.35

AUTHORIZATION

Issued By: jimc Date _____

DECLARATION

I certify that I have read this application/permit and state that the information on all pages of this document is correct. I agree to comply with all City and County ordinances and State laws relating to building construction, and hereby authorize representatives of this City and County to enter upon the above mentioned property for inspection purposes.

Applicant's Signature [Signature]
 Print Name Sam Shin Date 4/29/96

***** VALIDATION *****
 PAID ON 29 Apr 1996 AT 12:40
 RECEIVED BY TERESAP station1/2 TRANS# 72
 PAID BY CHECK#2156 FOR \$224.35
 TOTAL PAID = \$224.35



General Information: 714-741-5307

CITY OF GARDEN GROVE - DEVELOPMENT SERVICES DEPARTMENT

Inspection Requests: 714-741-5332

PERMIT (PAGE 2 of 2)

PROJECT/SITE/BUILDING DESCRIPTION

JOB Address : 13916 BROOKHURST ST
 Suite : A
 PERMIT NO. : 33434
 Permit Type : SIGN
 Type : B11
 SIGNS
 Owner : CHOE, KYONG SUN
 Applicant : T T SIGNS
 Appl Address : 15177 MORAN ST
 WESTMINSTER, CA 92683
 Phone : 714 373-4840

PROPOSED WORK:

2 ILLUMINATED WALL SIGNS

Insp Dist :
 Date : 05/30/96
 Parcel No : 09934413

FEES

Plan Check	1	39.00
Permit	1	60.00
Issuance	1	25.00
General Plan	1	4.85
Cultural Arts	1	2.40

INSPECTION RECORD

APPROVAL	DATE	INSPECTOR
Pre Inspect		
Foundation		
Concrete Floor		
Reinforcing		
Masonry		
Roof Shtg		
Rough Frame		
Insul / Energy		
Drywall		
Lath		
Plas. Brown Ct.		
Landscaping		
Pre Gunitite		
Pre Deck		
Pre Plaster		

11 3226 BLDG PERM &	60.00
11 3517 ISSUANCE FEE	25.00
11 3527 BLDG P C FEE	39.00
80 3224 PERMITS/CULT	2.40
92 2163 GENERAL PLAN	4.85

TOTAL 131.25

EXPIRED

Planning Final _____
 Bldg Final _____
 Utility Notified _____

AUTHORIZATION

Issued By: allenb Date _____

DECLARATION

I certify that I have read this application/permit and state that the information on all pages of this document is correct. I agree to comply with all City and County ordinances and State laws relating to building construction, and hereby authorize representatives of this City and County to enter upon the above mentioned property for inspection purposes.

Applicant's Signature Frank Mai
 Print Name FRANK MAI Date 5/30/96

***** VALIDATION *****
 PAID ON 30 May 1996 AT 11:36
 RECEIVED BY JULIAA station1/2 TRANS# 80
 PAID BY CHECK#1367 FOR \$179.25
 TOTAL PAID = \$179.25



General Information: 714-741-5307

CITY OF GARDEN GROVE - DEVELOPMENT SERVICES DEPARTMENT

Inspection Requests: 714-741-5332

PERMIT (PAGE 2 of 2)

PROJECT/SITE/BUILDING DESCRIPTION

JOB Address : 13916 BROOKHURST ST
 Suite : A
 PERMIT NO. : 33435
 Permit Type :
 Type : E

Owner : CHOE, KYONG SUN
 Applicant : T T SIGNS
 Appl Address : 15177 MORAN ST
 WESTMINSTER, CA 92683
 Phone : 714 373-4840

PROPOSED WORK:

ELECTRICAL HOOK UP FOR 2 WALL SIGNS

Insp Dist :
 Date : 05/30/96
 Parcel No : 09934413

FEES

SIGN HOOKUP	2	40.00
GENERAL PLAN	1	2.00
CULTURAL ARTS	1	1.00
MINIMUM ELECTRICAL FEE	1	5.00

INSPECTION RECORD

APPROVAL	DATE	INSPECTOR
----------	------	-----------

Underground _____
 Conduit _____
 Wiring - Rough _____
 Heater _____
 Fixtures & Trim _____
 Motors _____
 Ufer _____
 Service _____

11 3227 ELECTRICAL P	45.00
80 3224 PERMITS/CULT	1.00
92 2163 GENERAL PLAN	2.00

TOTAL 48.00

EXPIRED

FINAL 2-12-97 *[Signature]*
 Utility Notified _____

AUTHORIZATION

Issued By: allenb Date _____

DECLARATION

I certify that I have read this application/permit and state that the information on all pages of this document is correct. I agree to comply with all City and County ordinances and State laws relating to building construction, and hereby authorize representatives of this City and County to enter upon the above mentioned property for inspection purposes.

Applicant's Signature [Signature]
 Print Name THANH MA Date 5/30/90

***** VALIDATION *****
 PAID ON 30 May 1996 AT 11:36
 RECEIVED BY JULIAA station 1/2 TRANS# 80
 PAID BY CHECK#1367 FOR \$179.25
 TOTAL PAID = \$179.25

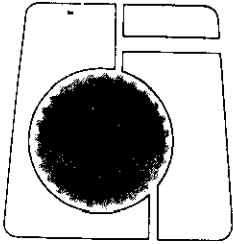

GARDEN GROVE

CITY OF GARDEN GROVE, CALIFORNIA

DEVELOPMENT SERVICES DEPARTMENT/CODE ENFORCEMENT SECTION

SIGN FIELD CHECK

PLEASE COMPLETE TOP HALF AND SUBMIT WITH PERMIT APPLICATION.

PERMIT # _____

APPLICATION DATE 5/23/96

SITE ADDRESS: 13916 BROOKHURST ST, GARDEN GROVE, CA 92643

BUSINESS NAME: LASER KARAOKE

PERSON TO CONTACT: THANH MAI PHONE: 373-4840

CONTRACTOR: T T SIGNS PHONE: 373-4840

BUSINESS OWNER: SING YOUNG PHONE: 638-3388

COPIES OF THE FOLLOWING SHALL BE SUBMITTED WITH EACH APPLICATION:

- BUILDING PERMIT: (form provided by the City) *not required for painted on wall sign*
- PLOT PLAN: Show Dimensions, setbacks, existing signs, proposed signs, existing buildings. (form provided by the city)
- ELEVATIONS: Two (2) copies showing existing and proposed sign locations.
- DETAILED DRAWINGS: Two (2) scaled drawings showing colors, materials, mounting method, copy and dimensions of proposed sign(s).
- ELECTRICAL PERMIT: Required for illuminated signs.

Please allow 3 to 5 days processing time for sign approval.

DEPARTMENT USE ONLY

ZONE: <u>C-1</u>	PRIMARY	SECONDARY	SPECIFIC SIGN CRITERIA <input checked="" type="checkbox"/>
Building frontage	_____	_____	_____
Lot frontage	_____	_____	_____
Allowable area	_____	_____	_____

EXISTING SIGNS		PROPOSED SIGNS		<input checked="" type="checkbox"/> APPROVED <input type="checkbox"/> DENIED
TYPE	AREA	TYPE	AREA	
1. _____	_____	5. <u>1- Single Channel letter sign - East</u>	<u>46 s.f.</u>	DATE: <u>5/30/96</u>
2. _____	_____	6. <u>Elevation - 2' x 23'</u>	_____	
3. _____	_____	7. _____	_____	
4. _____	_____	8. <u>1- Single Channel letter sign - North</u>	_____	
TOTAL	_____	TOTAL	<u>66 s.f.</u>	
COMBINED TOTAL	_____	TOTAL	<u>112 s.f.</u>	BY: <u>P. UNK</u>

Comments, Conditions, Recommendations: _____

CITY OF GARDEN GROVE - DEVELOPMENT SERVICES DEPARTMENT - PLOT PLAN FORM

Planning action:	Use zone:
Land use approved by: <i>F. WSG</i> Date: <i>5/30/96</i>	Lot size:
Remarks:	Lot coverage:
	\$ increase

Job address: <i>13916-A BROOKHURST</i>		Permit No. <i>33434/435</i>	
Assessor Parcel No.:		Legal desc.:	
Occupancy:	Const. type: <i>SIWNS</i>	Sprinklers:	Value: <i>2000.00</i>
<input checked="" type="checkbox"/> New	<input type="checkbox"/> Alter	<input type="checkbox"/> Add	<input type="checkbox"/> Repair <input type="checkbox"/> Demo

Job Description: *2-Illuminated wall signs*

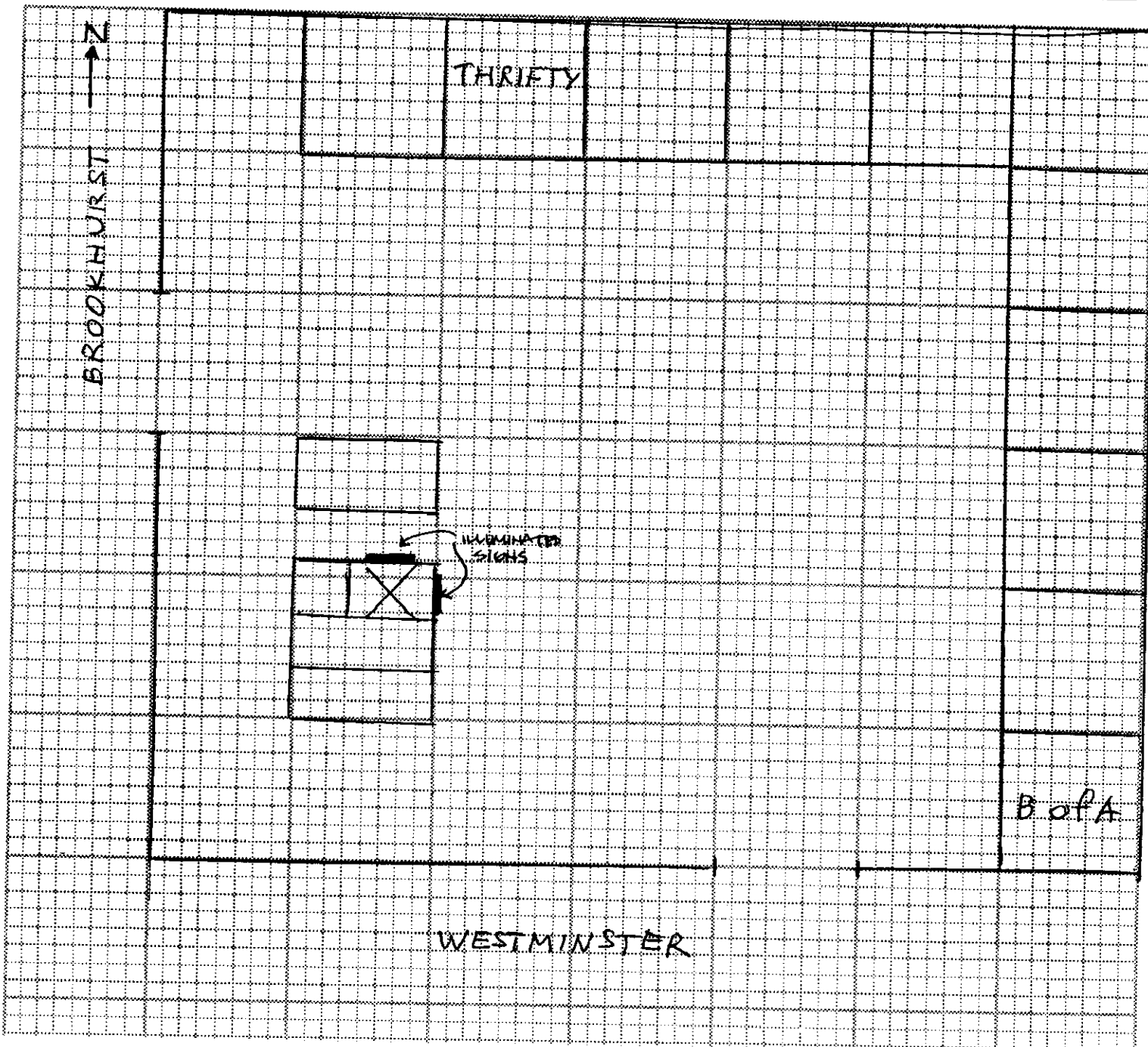

White: Inspection
 Yellow: Assessor
 Pink: Permittee

I certify the information hereon is complete & correct.
WINSTON CHOE *Winston Choe*
 Owner's name (print) Signature (owner/agent) *5/30/96*
 Date

CITY OF GARDEN GROVE - DEVELOPMENT SERVICES DEPARTMENT - PLOT PLAN FORM

Planning action:	Use zone:
Land use approved by: <i>WJL</i>	Lot size:
Remarks:	Lot coverage:
Date: <i>4/25/96</i>	± increase

Job address: <i>13916-A BROOKHURST AVE</i>	Permit No. <i>5742</i>			
Assessor Parcel No.	Legal desc.:			
Occupancy:	Const. type:	Sprinklers:	Value: <i>5000.00</i>	
<input type="checkbox"/> New	<input checked="" type="checkbox"/> Alter	<input type="checkbox"/> Add	<input type="checkbox"/> Repair	<input type="checkbox"/> Demo

Job Description: *Tenant Improvement*

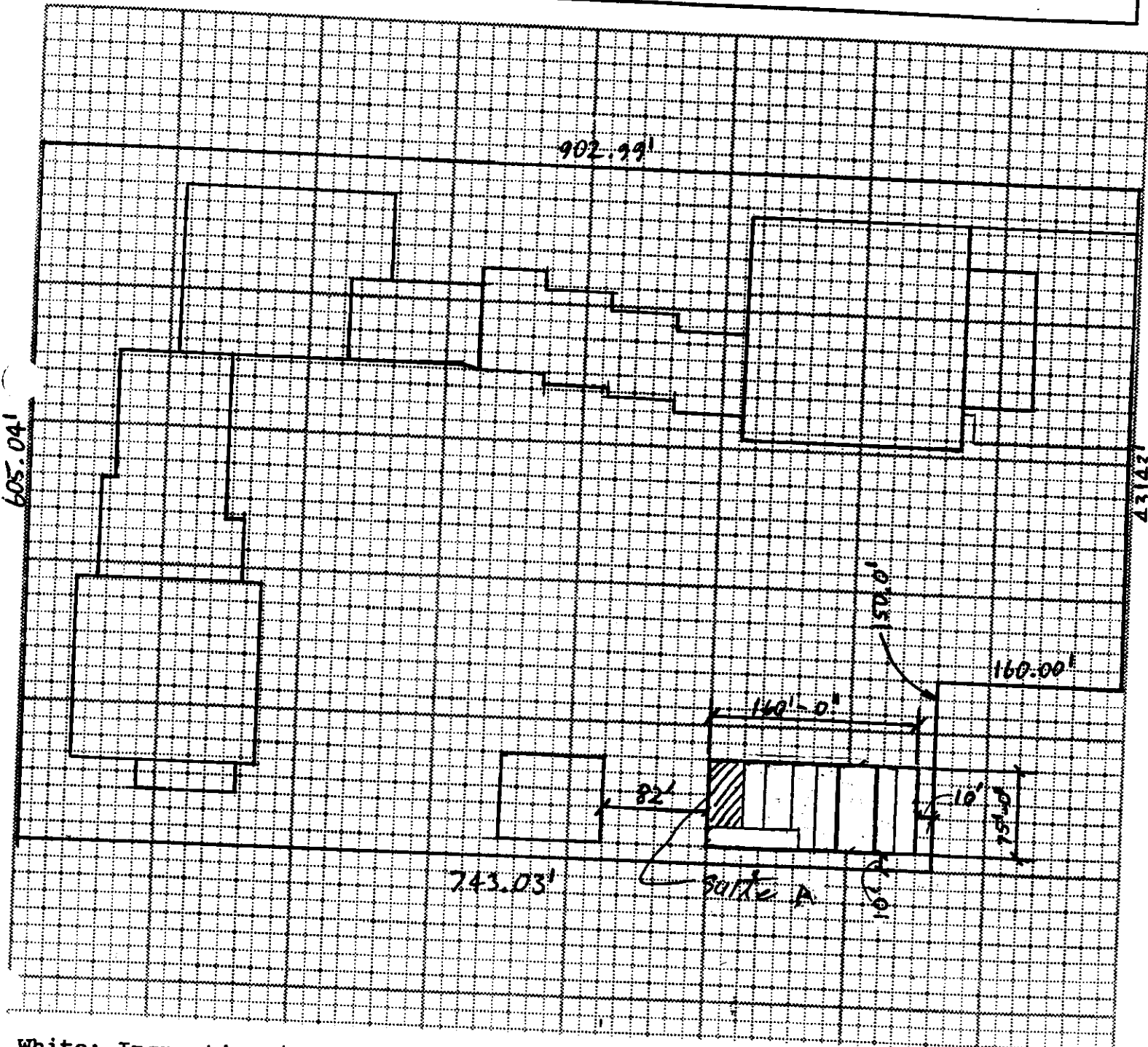

White: Inspection
 Yellow: Assessor
 Pink: Permittee

I certify the information hereon is complete & correct.
WINSTON CHOE
 Owner's name (print) Signature (owner/agent) Date *2/12/96*



General Information: 714-741-5307

CITY OF GARDEN GROVE - DEVELOPMENT SERVICES DEPARTMENT

Inspection Requests: 714-741-5332

PERMIT (PAGE 2 of 2)

PROJECT/SITE/BUILDING DESCRIPTION

PROPOSED WORK:

JOB Address : 13916 BROOKHURST ST
 Suite : ~~139~~ "A"
 PERMIT NO. : 32138
 Permit Type : BUILDING *See permit # 33075*
 Type : B7
 ALTERATIONS TO OTHER BUILDINGS
 Owner : CHOE, KYONG SUN
 Applicant : ACREAGE CONSTRUCTION CO.
 Appl Address : 1020 MICHELLE CT.
 MONTEBELLO, CA 90640
 Phone : 213 721-3927

DEMISING WALLS, ADD RESTROOM & T-BAR CEILING.

Insp Dist : ZB
 Date : 02/13/96
 Parcel No : 09934413

FEEES

Plan Check	1	64.68
Permit	1	100.00
Issuance	1	25.00
PLN.RET.LTR.SIZE	1	1.00
General Plan	1	9.55
Cultural Arts	1	4.70
PLAN CHECK FEE CREDIT	1	-64.68

INSPECTION RECORD

APPROVAL	DATE	INSPECTOR
----------	------	-----------

Pre Inspect _____
 Foundation _____
 Concrete Floor _____
 Reinforcing _____
 Masonry _____
 Roof Shtg _____
 Rough Frame 4/10/96 *[Signature]*
 Insul / Energy _____
 Drywall 4/23/96 *[Signature]*
 Lath _____
 Plas.Brown Ct. _____
 Landscaping _____
 Pre Gunite _____
 Pre Deck _____
 Pre Plaster _____

11 3226 BLDG PERM &	100.00
11 3517 ISSUANCE FEE	25.00
11 3527 BLDG P C FEE	0.00
11 3542 PLAN RETENTI	1.00
80 3224 PERMITS/CULT	4.70
92 2163 GENERAL PLAN	9.55
TOTAL	140.25

Planning Final 7/1/96 *[Signature]*
 Bldg Final 7/2/96 *[Signature]*
 Utility Notified _____

AUTHORIZATION

Issued By: jimc Date _____

DECLARATION

I certify that I have read this application/permit information on all pages of this document is correct, all City and County ordinances and State construction, and hereby authorize representative to enter upon the above mentioned property for insp

Applicant's Signature _____

Print Name _____ Date _____

***** VALIDATION *****
 PAID ON 13 Feb 1996 AT 17:30
 RECEIVED BY NANCYM station1/2 TRANS# 150
 PAID BY CHECK#2004 FOR \$1496.40
 TOTAL PAID = \$1496.40

CITY OF GARDEN GROVE - DEVELOPMENT SERVICES DEPARTMENT - PLOT PLAN FORM

Planning action:	Use zone:
Land use approved by:	Lot size:
Date:	Lot coverage:
Remarks:	% increase

Job address: 13916-A BROOKHURST AVE.	Permit No. 32137		
Assessor Parcel No. 09934413	Legal desc.:		
Occupancy:	Const. type:	Sprinklers:	Value: 6500 ⁰⁰
<input type="checkbox"/> New	<input checked="" type="checkbox"/> Alter	<input type="checkbox"/> Add	<input type="checkbox"/> Repair <input type="checkbox"/> Demo

Job Description: TENANT IMPROVEMENT / SUB-DIVISION
(ADD DEMISING WALLS TO CREATE 8 SEPARATE SUITES).

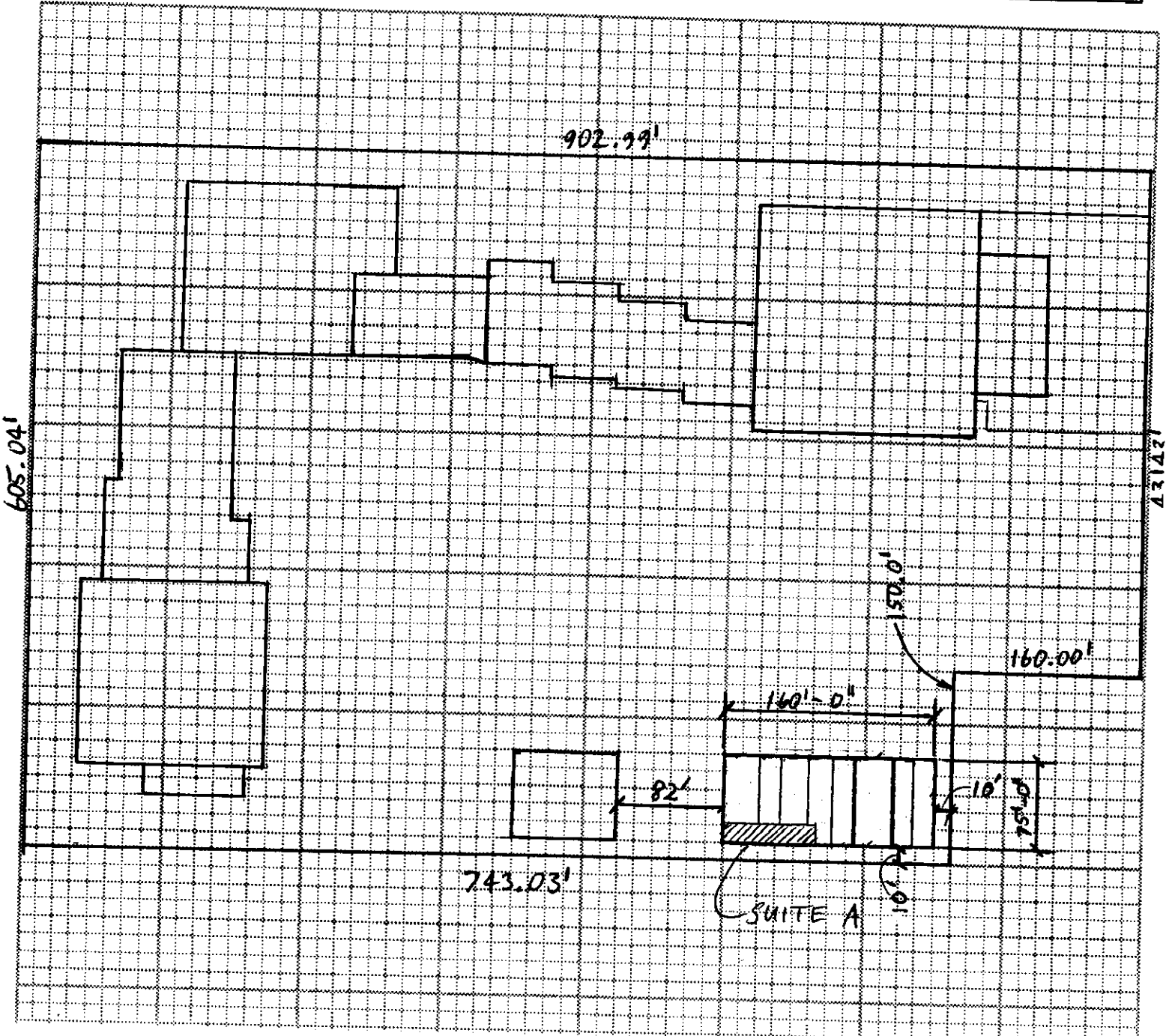

White: Inspection
Yellow: Assessor
Pink: Permittee

I certify the information hereon is complete & correct.
 Owner's name (print) WINSTON CHOE
 Signature (owner/agent) [Signature]
 Date 2/12/96

CHANNEL LETTER DETAIL

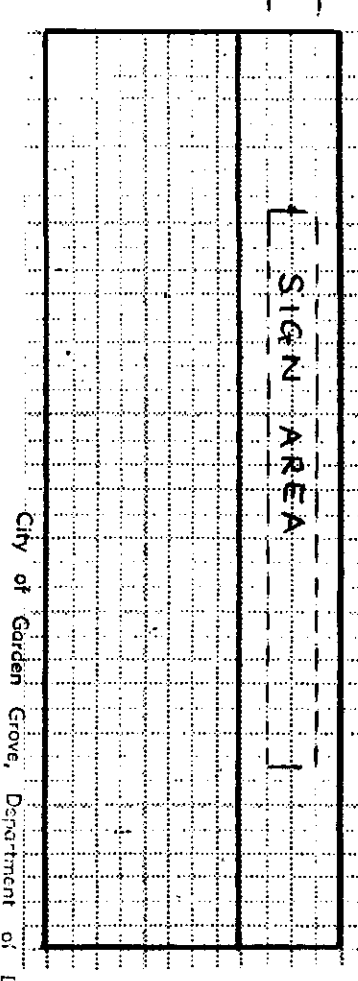
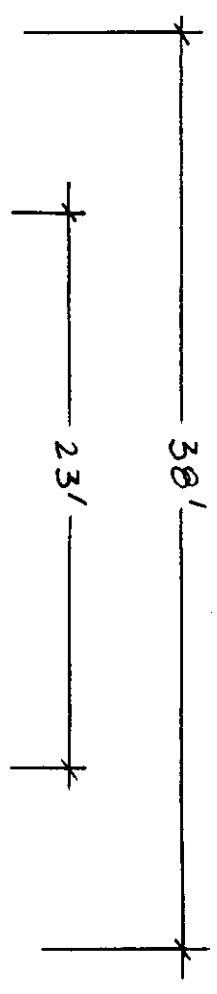

EAST ELEVATION

This set of plans & specifications must be kept on the job at all times and it is unlawful to make any changes or alterations on same without written permission from the Department of Development Services, City of Garden Grove, County of Orange. The starting of this plan & specifications SHALL NOT be held to account or to be on approval of the violation of any provisions of ANY City Ordinance or State Law, are made to determine that the plan and specifications required by the Garden Grove Municipal Code are satisfied. The City of Garden Grove does not guarantee construction to specifications contained in this plan which are greater than the minimum standards required by the Garden Grove Municipal Code.

APPROVED BY CATHERINE STANFORD, BUILDING OFFICIAL
 DATE 5/20/96 BY [Signature]

KARAOKE

— LOGO : WHITE BKGD , RED VINYL TEXT
 — LETTER STYLE : HELVETICA BOLD



Landlord's approval *Winston Chae*

Date 5-24-96

GARDEN GROVE SHOPPING PLAZA
 13872 Brookhurst St.
 Garden Grove, CA 92643
 (714) 537-6424

APPROVED
SIGN CODE DIV.
 CITY OF GARDEN GROVE

BY *P. O'SZ*
 DATE *5/20/96*
 COMMENTS *for redrail sales of karaoke video tapes, ect.*

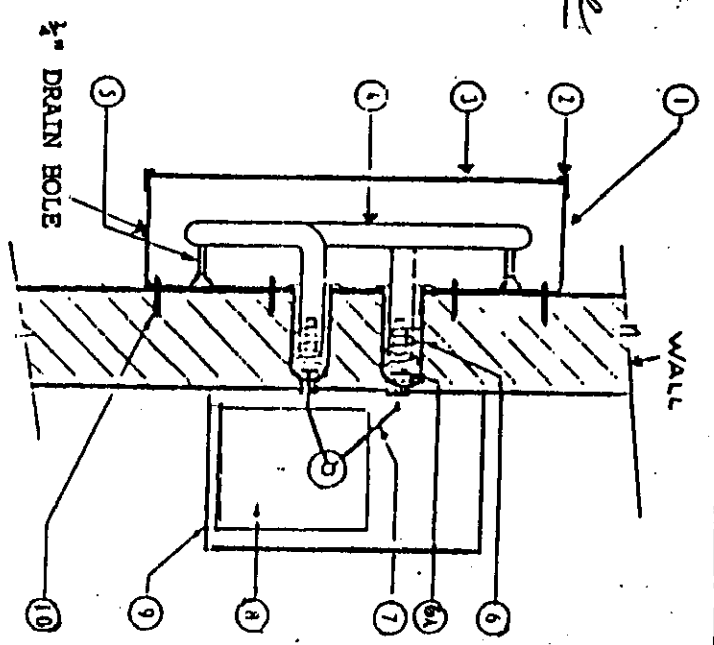

- 1) 5in. deep sheet metal can sealed to eliminate light leaks, returns painted BLACK
- 2) 3/4in. BLACK trimcap
- 3) Acrylic #4687 YELLOW plex faces
- 4) 15mm neon tubing interior illumination system.
- 5) Glass tube supports
- 6) UL approved electrode housing. "PK housings"
- 6a) Strain relief disk
- 7) High-tension GRO cable to transformer
- 8) 15,000V, 30MA transformer
- 9) Transformer box with cutoff switch
- 10) 4-6 1/2in. X 2in. screws per letter

T & T SIGNS
 15177 MORAN STREET
 WESTMINSTER, CA 92683
 Kim Thanh Mai, Contractor
 PH (714) 373-4840 FAX (714) 373-0360

CHANNEL LETTER DETAIL

Landlord's approval

Winston Choe

Date 5-24-96

GARDEN GROVE SHOPPING PLAZA
 13872 Brookhurst St.
 Garden Grove, CA 92643
 (714) 537-6424

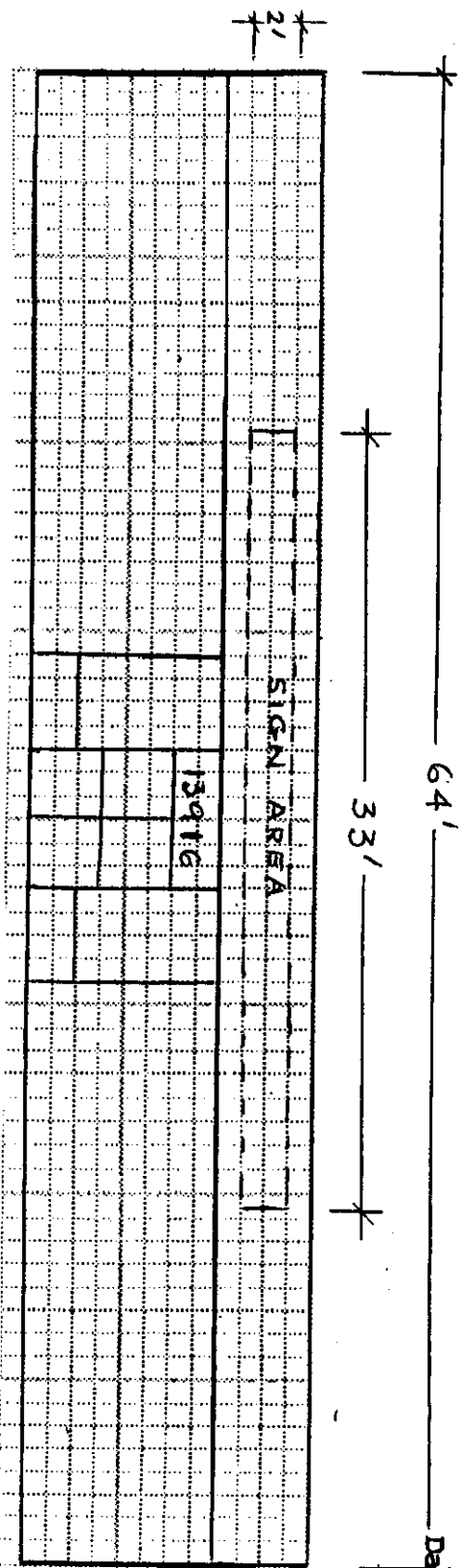

NORTH ELEVATION

LASER KARAOKE

- LOGO: WHITE PLEX BKGD, RED VINYL TEXT

- LETTER STYLE: HELVETICA BOLD

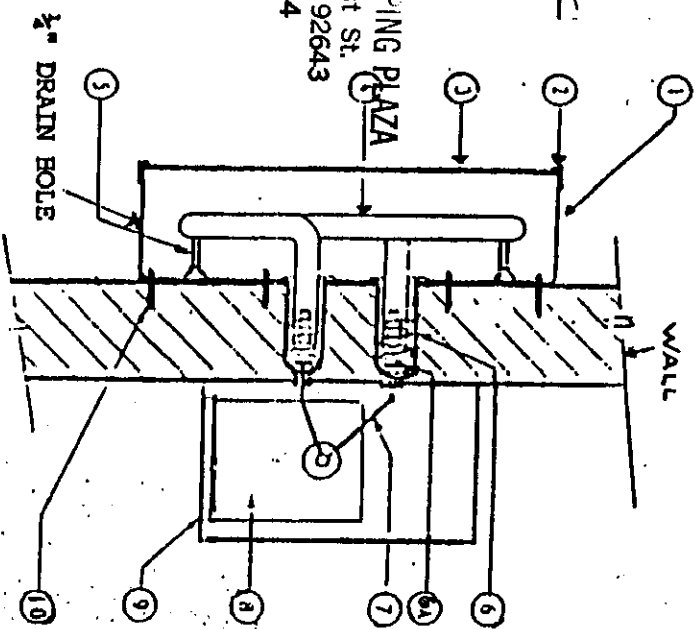

- 1) 5/8" deep sheet metal can sealed to eliminate light leaks, returns painted BLACK
- 2) 3/4" BLACK trimcap
- 3) Acrylic #4687 YELLOW plex faces
- 4) 15mm neon tubing interior illumination system.
- 5) Glass tube supports
- 6) UL approved electrode housing. "PK housings"
- 6A) Strain relief disk
- 7) High-tension GTO cable to transformer
- 8) 15,000V, 30MA transformer
- 9) Transformer box with cutoff switch
- 10) 4-6 1/2 in. X 2 in. screws per letter

T & T SIGNS
 15177 MORAN STREET
 WESTMINSTER, CA 92683
 Kim Thanh Mai, Contractor
 PH (714) 373-4840 FAX (714) 373-0360



PERMIT (PAGE 2 of 2)

PROJECT/SITE/BUILDING DESCRIPTION

JOB Address : 13916 BROOKHURST ST
 Suite : ~~##~~ "F"
 PERMIT NO. : 32147
 Permit Type :
 Type : P
 Owner : CHOE, KYONG SUN
 Applicant : ACREAGE CONSTRUCTION CO.
 Appl Address : 1020 MICHELLE CT.
 MONTEBELLO, CA 90640
 Phone : 213 721-3927
 Insp Dist : ZP
 Date : 02/13/96
 Parcel No : 09934413

PROPOSED WORK:

ADDITION OF RESTROOM TO STORE SPACE.

FEEES

Water Closet	1	8.00
Lavatory	1	8.00
BACKFLOW PROT DEV 2" MAX	1	8.00
Issuance	1	25.00
GENERAL PLAN	1	2.00
CULTURAL ARTS	1	1.00

B# 32137

INSPECTION RECORD

APPROVAL	DATE	INSPECTOR
Soil Piping	_____	_____
Ground Plumbing	_____	_____
Rough Plumbing	_____	_____
Gas Piping	_____	_____
Gas Vent	_____	_____
Sewer	_____	_____
Main Drain	_____	_____
Vacuum Lines	_____	_____
Water Heater	_____	_____
Backwash	_____	_____
Water Lateral	_____	_____

11 3228 PLUMBING PER	24.00
11 3517 ISSUANCE FEE	25.00
80 3224 PERMITS/CULT	1.00
92 2163 GENERAL PLAN	2.00

TOTAL 52.00

AUTHORIZATION

Issued By: jimc Date _____

DECLARATION

I certify that I have read this application/permit and state that the information on all pages of this document is correct. I agree to comply with all City and County ordinances and State laws relating to building construction, and hereby authorize representatives of this City and County to enter upon the above mentioned property for inspection purposes.

Applicant's Signature _____

Print Name _____ Date _____

FINAL 6.17.96 Arner

Utility Notified _____

***** VALIDATION *****
 PAID ON 13 Feb 1996 AT 17:30
 RECEIVED BY NANCYM station1/2 TRANS# 150
 PAID BY CHECK#2004 FOR \$1496.40
 TOTAL PAID = \$1496.40



General Information: 714-741-5307

CITY OF GARDEN GROVE - DEVELOPMENT SERVICES DEPARTMENT

Inspection Requests: 714-741-5332

PERMIT (PAGE 2 of 2)

PROJECT/SITE/BUILDING DESCRIPTION

JOB Address : 13916 BROOKHURST ST
 Suite : ~~13916~~
 PERMIT NO. : 32152
 Permit Type :
 Type : P
 Owner : CHOE, KYONG SUN
 Applicant : ACREAGE CONSTRUCTION CO.
 Appl Address : 1020 MICHELLE CT.
 MONTEBELLO, CA 90640
 Phone : 213 721-3927
 Insp Dist : ZP
 Date : 02/13/96
 Parcel No : 09934413

PROPOSED WORK:

ADDITION OF RESTROOM IN STORE SPACE.

FEES

Water Closet	1	8.00
Lavatory	1	8.00
Issuance	1	25.00
GENERAL PLAN	1	2.00
CULTURAL ARTS	1	1.00
MINIMUM PLUMBING FEE	1	4.00

B # 32145

INSPECTION RECORD

APPROVAL	DATE	INSPECTOR
Soil Piping		
Ground Plumbing		
Rough Plumbing		
Gas Piping		
Gas Vent		
Sewer		
Main Drain		
Vacuum Lines		
Water Heater		
Backwash		
Water Lateral		

11 3228 PLUMBING PER	20.00
11 3517 ISSUANCE FEE	25.00
80 3224 PERMITS/CULT	1.00
92 2163 GENERAL PLAN	2.00

TOTAL 48.00

AUTHORIZATION

Issued By: jimc _____ Date _____

DECLARATION

I certify that I have read this application/permit and state that the information on all pages of this document is correct. I agree to comply with all City and County ordinances and State laws relating to building construction, and hereby authorize representatives of this City and County to enter upon the above mentioned property for inspection purposes.

Applicant's Signature _____

Print Name _____ Date _____

FINAL 6-17-96

Utility Notified _____

***** VALIDATION *****
 PAID ON 13 Feb 1996 AT 17:30
 RECEIVED BY NANCYM station1/2 TRANS# 150
 PAID BY CHECK#2004 FOR \$1496.40
 TOTAL PAID = \$1496.40



General Information: 714-741-5307

CITY OF GARDEN GROVE - DEVELOPMENT SERVICES DEPARTMENT

Inspection Requests: 714-741-5332

PERMIT (PAGE 2 of 2)

PROJECT/SITE/BUILDING DESCRIPTION

JOB Address : 13916 BROOKHURST ST
 Suite : ~~#~~ D
 PERMIT NO. : 32151
 Permit Type :
 Type : P

Owner : CHOE, KYONG SUN
 Applicant : ACREAGE CONSTRUCTION CO.
 Appl Address : 1020 MICHELLE CT.
 MONTEBELLO, CA 90640
 Phone : 213 721-3927

Insp Dist : ZP
 Date : 02/13/96
 Parcel No : 09934413

PROPOSED WORK:

ADDITION OF RESTROOM IN STORE SPACE.

FEES

Water Closet	1	8.00
Lavatory	1	8.00
Issuance	1	25.00
GENERAL PLAN	1	2.00
CULTURAL ARTS	1	1.00
MINIMUM PLUMBING FEE	1	4.00

B# 32142

INSPECTION RECORD

APPROVAL	DATE	INSPECTOR
Soil Piping		
Ground Plumbing		
Rough Plumbing		
Gas Piping		
Gas Vent		
Sewer		
Main Drain		
Vacuum Lines		
Water Heater		
Backwash		
Water Lateral		

11 3228 PLUMBING PER	20.00
11 3517 ISSUANCE FEE	25.00
80 3224 PERMITS/CULT	1.00
92 2163 GENERAL PLAN	2.00

TOTAL 48.00

AUTHORIZATION

Issued By: jimc Date _____

DECLARATION

I certify that I have read this application/permit and state that the information on all pages of this document is correct. I agree to comply with all City and County ordinances and State laws relating to building construction, and hereby authorize representatives of this City and County to enter upon the above mentioned property for inspection purposes.

Applicant's Signature [Signature]

Print Name Sam C. Skire Date 2/13/96

FINAL 6.17.96 Aron

Utility Notified _____

***** VALIDATION *****
 PAID ON 13 Feb 1996 AT 17:30
 RECEIVED BY NANCYM station1/2 TRANS# 150
 PAID BY CHECK#2004 FOR \$1496.40
 TOTAL PAID = \$1496.40



General Information: 714-741-5307

CITY OF GARDEN GROVE - DEVELOPMENT SERVICES DEPARTMENT

Inspection Requests: 714-741-5332

PERMIT (PAGE 2 of 2)

PROJECT/SITE/BUILDING DESCRIPTION

JOB Address : 13916 BROOKHURST ST
 Suite : ~~13916~~ 13916
 PERMIT NO. : 32150
 Permit Type :
 Type : P
 Owner : CHOE, KYONG SUN
 Applicant : ACREAGE CONSTRUCTION CO.
 Appl Address : 1020 MICHELLE CT.
 MONTEBELLO, CA 90640
 Phone : 213 721-3927
 Insp Dist : ZP
 Date : 02/13/96
 Parcel No : 09934413

PROPOSED WORK:

ADDITON OF RESTROOM IN STORE SPACE.

FEEES

Water Closet	1	8.00
Lavatory	1	8.00
Issuance	1	25.00
GENERAL PLAN	1	2.00
CULTURAL ARTS	1	1.00
MINIMUM PLUMBING FEE	1	4.00

B# 32140

INSPECTION RECORD

APPROVAL	DATE	INSPECTOR
Soil Piping		
Ground Plumbing		
Rough Plumbing		
Gas Piping		
Gas Vent		
Sewer		
Main Drain		
Vacuum Lines		
Water Heater		
Backwash		
Water Lateral		

11 3228 PLUMBING PER	20.00
11 3517 ISSUANCE FEE	25.00
80 3224 PERMITS/CULT	1.00
92 2163 GENERAL PLAN	2.00

TOTAL 48.00

AUTHORIZATION

Issued By: jimc _____ Date _____

DECLARATION

I certify that I have read this application/permit and state that the information on all pages of this document is correct. I agree to comply with all City and County ordinances and State laws relating to building construction, and hereby authorize representatives of this City and County to enter upon the above mentioned property for inspection purposes.

Applicant's Signature _____

Print Name _____ Date _____

Utility Notified _____

***** VALIDATION *****
 PAID ON 13 Feb 1996 AT 17:30
 RECEIVED BY NANCYM station1/2 TRANS# 150
 PAID BY CHECK#2004 FOR \$1496.40
 TOTAL PAID = \$1496.40



General Information: 714-741-5307

CITY OF GARDEN GROVE - DEVELOPMENT SERVICES DEPARTMENT

Inspection Requests: 714-741-5332

PERMIT (PAGE 2 of 2)

PROJECT/SITE/BUILDING DESCRIPTION

JOB Address : 13916 BROOKHURST ST
 Suite : ~~# B~~
 PERMIT NO. : 32149
 Permit Type :
 Type : P

Owner : CHOE, KYONG SUN
 Applicant : ACREAGE CONSTRUCTION CO.
 Appl Address : 1020 MICHELLE CT.
 MONTEBELLO, CA 90640
 Phone : 213 721-3927

Insp Dist : ZP
 Date : 02/13/96
 Parcel No : 09934413

PROPOSED WORK:

ADDITION OF RESTROOM IN STORE SPACE.

FEEES

Water Closet	1	8.00
Lavatory	1	8.00
GENERAL PLAN	1	2.00
CULTURAL ARTS	1	1.00
Issuance	1	25.00
MINIMUM PLUMBING FEE	1	4.00

B# 32139

INSPECTION RECORD

APPROVAL	DATE	INSPECTOR
Soil Piping	_____	_____
Ground Plumbing	_____	_____
Rough Plumbing	_____	_____
Gas Piping	_____	_____
Gas Vent	_____	_____
Sewer	_____	_____
Main Drain	_____	_____
Vacuum Lines	_____	_____
Water Heater	_____	_____
Backwash	_____	_____
Water Lateral	_____	_____

11 3228 PLUMBING PER	20.00
11 3517 ISSUANCE FEE	25.00
80 3224 PERMITS/CULT	1.00
92 2163 GENERAL PLAN	2.00

TOTAL 48.00

AUTHORIZATION

Issued By: jimc Date _____

DECLARATION

I certify that I have read this application/permit and state that the information on all pages of this document is correct. I agree to comply with all City and County ordinances and State laws relating to building construction, and hereby authorize representatives of this City and County to enter upon the above mentioned property for inspection purposes.

Applicant's Signature _____

Print Name _____ Date _____

FINAL 6.17.96 Arora

Utility Notified _____

***** VALIDATION *****
 PAID ON 13 Feb 1996 AT 17:30
 RECEIVED BY NANCYM station1/2 TRANS# 150
 PAID BY CHECK#2004 FOR \$1496.40
 TOTAL PAID = \$1496.40



General Information: 714-741-5307

CITY OF GARDEN GROVE - DEVELOPMENT SERVICES DEPARTMENT

Inspection Requests: 714-741-5332

PERMIT (PAGE 2 of 2)

PROJECT/SITE/BUILDING DESCRIPTION

JOB Address : 13916 BROOKHURST ST
 Suite : A
 PERMIT NO. : 33076
 Permit Type :
 Type : E

Owner : CHOE, KYONG SUN
 Applicant : ACREAGE CONSTRUCTION CO.
 Appl Address : 1020 MICHELLE CT.
 MONTEBELLO, CA 90640
 Phone : 213 721-3927

Insp Dist : ZE
 Date : 04/29/96
 Parcel No : 09934413

PROPOSED WORK:

ELEC FOR T.I.

FEES

Outlets 1-20	4	3.20
Issuance	1	25.00
GENERAL PLAN	1	2.00
CULTURAL ARTS	1	1.00
MINIMUM ELECTRICAL FEE	1	16.80

INSPECTION RECORD

APPROVAL	DATE	INSPECTOR
Underground		
Conduit		
Wiring - Rough		
Heater		
Fixtures & Trim		
Motors		
Ufer		
Service		

11 3227 ELECTRICAL P	20.00
11 3517 ISSUANCE FEE	25.00
80 3224 PERMITS/CULT	1.00
92 2163 GENERAL PLAN	2.00
TOTAL	48.00

AUTHORIZATION

Issued By: jimc _____ Date _____

DECLARATION

I certify that I have read this application/permit and state that the information on all pages of this document is correct. I agree to comply with all City and County ordinances and State laws relating to building construction, and hereby authorize representatives of this City and County to enter upon the above mentioned property for inspection purposes.

Applicant's Signature [Signature]
Print Name Sam Shin Date 4/29/96

FINAL 6-17-96 [Signature]

Utility Notified _____

***** VALIDATION *****
 PAID ON 29 Apr 1996 AT 12:40
 RECEIVED BY TERESAP station1/2 TRANS# 72
 PAID BY CHECK#2156 FOR \$224.35
 TOTAL PAID = \$224.35



General Information: 714-741-5307

CITY OF GARDEN GROVE - DEVELOPMENT SERVICES DEPARTMENT

Inspection Requests: 714-741-5332

PERMIT (PAGE 2 of 2)

PROJECT/SITE/BUILDING DESCRIPTION

JOB Address : 13916 BROOKHURST ST
 Suite : ~~13916~~ ¹³⁹¹⁶
 PERMIT NO. : 32148
 Permit Type :
 Type : P

Owner : CHOE, KYONG SUN
 Applicant : ACREAGE CONSTRUCTION CO.
 Appl Address : 1020 MICHELLE CT.
 MONTEBELLO, CA 90640
 Phone : 213 721-3927

Insp Dist : ZP
 Date : 02/13/96
 Parcel No : 09934413

PROPOSED WORK:

ADDITION OF RESTROOM FOR STORE SPACE.

FEEES

Water Closet	1	8.00
Lavatory	1	8.00
Issuance	1	25.00
GENERAL PLAN	1	2.00
CULTURAL ARTS	1	1.00
MINIMUM PLUMBING FEE	1	4.00

Bldg permit # 32138

INSPECTION RECORD

APPROVAL	DATE	INSPECTOR
Soil Piping	_____	_____
Ground Plumbing	_____	_____
Rough Plumbing	_____	_____
Gas Piping	_____	_____
Gas Vent	_____	_____
Sewer	_____	_____
Main Drain	_____	_____
Vacuum Lines	_____	_____
Water Heater	_____	_____
Backwash	_____	_____
Water Lateral	_____	_____

11 3228 PLUMBING PER	20.00
11 3517 ISSUANCE FEE	25.00
80 3224 PERMITS/CULT	1.00
92 2163 GENERAL PLAN	2.00

TOTAL 48.00

AUTHORIZATION

Issued By: jimc Date _____

DECLARATION

I certify that I have read this application/permit and state that the information on all pages of this document is correct. I agree to comply with all City and County ordinances and State laws relating to building construction, and hereby authorize representatives of this City and County to enter upon the above mentioned property for inspection purposes.

Applicant's Signature _____

Print Name _____ Date _____

FINAL 6.17.96 *[Signature]*

Utility Notified _____

***** VALIDATION *****
 PAID ON 13 Feb 1996 AT 17:30
 RECEIVED BY NANCYM station1/2 TRANS# 150
 PAID BY CHECK#2004 FOR \$1496.40
 TOTAL PAID = \$1496.40



General Information: 714-741-5307

CITY OF GARDEN GROVE - DEVELOPMENT SERVICES DEPARTMENT

Inspection Requests: 714-741-5332

PERMIT (PAGE 2 of 2) *33404*

PROJECT/SITE/BUILDING DESCRIPTION

JOB Address : 13916 BROOKHURST ST
 Suite : 13916-13920
 PERMIT NO. : 33404
 Permit Type :
 Type : E
 Owner : CHOE, KYONG SUN
 Applicant : AMCO ELECTRIC
 Appl Address : 19432 E SPRINGPORT DR
 ROWLAND HEIGHTS, CA 91748
 Phone : 9095954538
 Insp Dist : ZE
 Date : 05/29/96
 Parcel No : 09934413

PROPOSED WORK:

REVISION OF MAIN SWBD SUBJECT TO FIELD INSPECTION.

FEES

Service Over 200 Amp	1	40.00
Plan Check	1	26.00
PLAN CHECK FEE CREDIT	1	-26.00
Issuance	1	25.00
GENERAL PLAN	1	2.00
CULTURAL ARTS	1	1.00

INSPECTION RECORD

APPROVAL DATE INSPECTOR

Underground _____
 Conduit _____
 Wiring - Rough _____
 Heater _____
 Fixtures & Trim _____
 Motors _____
 Ufer _____
 Service _____

11 3227 ELECTRICAL P	40.00
11 3517 ISSUANCE FEE	25.00
11 3524 ELECTRICAL P	26.00
11 3527 BLDG P C FEE	0.00
80 3224 PERMITS/CULT	1.00
92 2163 GENERAL PLAN	2.00
TOTAL	68.00

COPY

AUTHORIZATION

Issued By: _____ Date _____

DECLARATION

I certify that I have read this application/permit and state that the information on all pages of this document is correct. I agree to comply with all City and County ordinances and State laws relating to building construction, and hereby authorize representatives of this City and County to enter upon the above mentioned property for inspection purposes.

Applicant's Signature _____

Print Name _____ Date _____

FINAL *6-17-96* *[Signature]*
 Utility Notified *6/17/96* *[Signature]*
7-METERS