

Subject: Agreement for Reimbursement - Land & Design, Inc.

From: Alana Cheng <alanac@ci.garden-grove.ca.us>

Date: Tue, 4 Aug 2015 11:18:24 -0700 (PDT)

To: Greg Blodgett <gregl@ci.garden-grove.ca.us>, Matthew Reid <matt.reid@landanddesign.com>

CC: Jayna Morgan <jayna.morgan@aecom.com>, Karl Hill <karlh@ci.garden-grove.ca.us>, Maria Parra <mariap@ci.garden-grove.ca.us>

Hi all,

Please have this agreement executed and mailed back to the City.

Let me know if you have questions.

Thanks,

Alana

Land & Design, Inc.CEQA REVIEW REIMBURSEMENT AGREEMENT w. AECOM 7.28.15.doc

Content-Type: application/msword

Content-Encoding: base64

**AGREEMENT FOR REIMBURSEMENT
FOR PREPARATION OF
ENVIRONMENTAL CLEARANCE DOCUMENTS**

This Agreement is made and entered into as of the ___ day of _____, 2015, by and between the **City of Garden Grove** ("City") and **Land & Design, Inc.** ("Developer") (collectively referred to as the "parties").

RECITALS

- A. Developer seeks to construct a project in the City of Garden Grove; and
- B. Such project requires that environmental clearance and review be completed in compliance with the California Environmental Quality Act ("CEQA"); and
- C. City will hire a consultant to complete the required environmental review; and
- D. Developer acknowledges and agrees that the costs associated with the preparation of environmental clearance and environmental review documents are project specific costs that are the responsibility of the Developer as part of the entitlement process.

AGREEMENT

1. Selection of Consultant. Developer acknowledges and agrees that there is a need to hire an independent third party consultant to use his/her own professional judgment to conduct and prepare the environmental clearance and environmental review documents. City reserves the right to contract the most qualified consultant through the third party contract at the discretion of the Community Development Director ("Director").
2. Method of Payment. Developer shall deposit 100% of the estimated total cost of completing the environmental review prior to commencement of the environmental review. **No work shall be performed by an environmental review consultant until Developer has deposited such money with the City.** City shall keep the money deposited to complete the environmental review in a separate non-interest bearing account and will use the money to pay for the consultant's services. When the City has depleted the funds in the account, City shall immediately notify Developer of the additional funds necessary to complete the environmental review. Further, City shall notify consultant that no work should continue on the environmental review process until Developer has deposited additional funds with the City. If Developer fails to provide additional funds to the City, no further environmental review shall be completed. Developer shall be responsible for all costs incurred by the City for the consultant's services up

until the point that the City notifies the consultant to stop work on the project.

3. Administration Costs. In addition to the cost of completing the environmental review, the amounts reimbursed by Developer shall include administrative the costs incurred by City, including, without limitation, staff time, fees and services, which shall be reimbursed on a time and materials basis based on current City reimbursement rates.
4. Examination of Bills. Developer shall have the right to examine all invoices of the environmental consultant that are submitted to the City. Once Developer has made the request to review the invoices from the consultant, City shall have 10 days to copy and produce such invoices for inspection by Developer.
5. Authority of City. Because City has the ultimate authority and responsibility to prepare and review the environmental documents prior to approval of a project, City shall guide the environmental consultant as to the appropriate considerations for the review. If additional environmental or technical studies are required as a result of comments received from internal and external agencies, Developer is solely responsible for the costs of such studies. Nothing in this Agreement is meant to be a guarantee that Developer's project will be approved or that the environmental clearance will be obtained. Further, nothing in this Agreement specifies or guarantees the timing of completion of the environmental clearance and review or other related documents. The City has discretion under its police powers to approve land development projects in accordance with pertinent laws and policies.
6. Indemnity. Developer agrees to defend, indemnify and hold harmless the City, its officers, agents, employees and volunteers from and against any and all claims, demands, actions, losses, damages, injuries, and liability, direct or indirect (including any and all related costs and expenses in connection therein), arising out of the performance of this Agreement, except for any such claim arising out of the sole negligence or willful misconduct of the City, its officers, agents, employees or volunteers.
7. No Inducement. Developer declares and represents that no promise, inducement or agreement not herein expressed has been made to it and that this Agreement contains the entire agreement between and among the parties, and that the terms of this Agreement are contractual and not a mere recital. This Agreement is entered into knowingly, freely, intelligently, and voluntarily by the parties, without any duress, or coercion. The parties have had a full opportunity to review and consider the matter prior to executing this Agreement. The parties fully acknowledge that they also have had a full opportunity to discuss its contents with their respective representatives.

15. Termination. This Agreement may be terminated with thirty (30) days notice if Developer decides not to proceed with the proposed development project. Upon termination, Developer shall be responsible for compensation of the consultant's services performed up to the effective date of termination.

16. Insolvency; Receiver. Either the appointment of a receiver to take possession of all or substantially all of the assets of Developer, or a general assignment by Developer for the benefit of creditors, or any action taken or offered by Developer under any insolvency or bankruptcy action, will constitute a breach of this Agreement by Developer, and in such event this Agreement will automatically cease and terminate.

17. Developer Default. Should Developer fail to perform any of its obligations under this Agreement, then City may, at its option, pursue any one or more or all of the remedies available to it under this Agreement, at law or in equity. Without limiting any other remedy which may be available to it, if Developer fails to perform any of its obligations under this Agreement, City may cease performing its obligations under this Agreement and may bring an action to recover all costs and expenses incurred by the City in completing the Studies, together with interest thereon from the date incurred at the rate of 10% per annum.

IN WITNESS WHEREOF, the parties have caused this Agreement to be executed on the date first written above.

CITY:

DEVELOPER:

 Susan Emery
 Assistant City Manager

 By:
 Its:

ATTEST:

 City Clerk

 By:
 Its:

APPROVED AS TO FORM:

 City Attorney

Subject: Soils

From: Matthew Reid <matt.reid@landanddesign.com>

Date: Thu, 6 Aug 2015 14:02:48 -0700

To: Greg Blodgett <Greg1@ci.garden-grove.ca.us>

Greg,

Did you ever send me the soils report for the site?

Matthew Reid

Land & Design, Inc.

3755 Avocado Blvd | #516 | LaMesa, CA 91942

858.735.1858 cell

Skype - matthew.reid.ca

matt.reid@landanddesign.com

Check out our new website www.landanddesign.com

Subject: Re: Soils

From: Greg Blodgett <greg1@ci.garden-grove.ca.us>

Date: Thu, 6 Aug 2015 14:19:13 -0700 (PDT)

To: Matthew Reid <matt.reid@landanddesign.com>

we did a study for compaction for the entitlements

----- Original Message -----

From: "Matthew Reid" <matt.reid@landanddesign.com>

To: "Greg Blodgett" <Greg1@ci.garden-grove.ca.us>

Sent: Thursday, August 6, 2015 2:02:48 PM

Subject: Soils

Greg,

Did you ever send me the soils report for the site?

Matthew Reid
Land & Design, Inc.
3755 Avocado Blvd | #516 | LaMesa, CA 91942
858.735.1858 cell
Skype - matthew.reid.ca
matt.reid@landanddesign.com

Check out our new website www.landanddesign.com

Subject: Re: Agreement for Reimbursement - Land & Design, Inc.
From: Alana Cheng <alanac@ci.garden-grove.ca.us>
Date: Thu, 6 Aug 2015 17:37:43 -0700 (PDT)
To: Matthew Reid <matt.reid@landanddesign.com>
CC: Greg Blodgett <greg1@ci.garden-grove.ca.us>, Jayna Morgan <jayna.morgan@aecom.com>, Karl Hill <karlh@ci.garden-grove.ca.us>, Maria Parra <mariap@ci.garden-grove.ca.us>, Dave Rose <drose3@charter.net>

Hi Matt,

I verified with staff that the Agreement for Reimbursement is only for the AECOM proposal.

Additional fees, whether it is entitlement fees or other City environmental costs, will be billed separately and not included with this Agreement.

Thank you for asking

Alana

From: "Matthew Reid" <matt.reid@landanddesign.com>
To: "Alana Cheng" <alanac@ci.garden-grove.ca.us>
Cc: "Greg Blodgett" <greg1@ci.garden-grove.ca.us>, "Jayna Morgan" <jayna.morgan@aecom.com>, "Karl Hill" <karlh@ci.garden-grove.ca.us>, "Maria Parra" <mariap@ci.garden-grove.ca.us>, "Dave Rose" <drose3@charter.net>
Sent: Thursday, August 6, 2015 2:28:24 PM
Subject: Re: Agreement for Reimbursement - Land & Design, Inc.

Thanks

Matthew Reid

Land & Design, Inc.
3755 Avocado Blvd | #516 | LaMesa, CA 91942
858.735.1858 cell
Skype - [matthew.reid.ca](https://www.skype.com/user/matthew.reid.ca)
matt.reid@landanddesign.com

Check out our new website www.landanddesign.com

On Aug 6, 2015, at 2:15 PM, Alana Cheng <alanac@ci.garden-grove.ca.us> wrote:

sure not a problem, let me verify and get back to you shortly.

thx,
alana

From: "Matthew Reid" <matt.reid@landanddesign.com>
To: "Alana Cheng" <alanac@ci.garden-grove.ca.us>
Cc: "Greg Blodgett" <greg1@ci.garden-grove.ca.us>, "Jayna Morgan" <jayna.morgan@aecom.com>, "Karl Hill" <karlh@ci.garden-grove.ca.us>, "Maria Parra" <mariap@ci.garden-grove.ca.us>, "Dave Rose" <drose3@charter.net>
Sent: Thursday, August 6, 2015 12:02:54 PM
Subject: Re: Agreement for Reimbursement - Land & Design, Inc.

Thanks Alana. For clarity, how much of a deposit do you require? The amount of AECOM's proposal?

Sent from my iPhone

Matthew Reid

Land & Design, Inc.

3755 Avocado Blvd | #516 | LaMesa, CA 91941

619.567.2447 x101 office

858.735.1858 cell

619.489.3669 efax

Skype - [matthew.reid.ca](https://www.skype.com/people/matthew.reid.ca)

matt.reid@landanddesign.com

Check out our new website www.landanddesign.com

On Aug 4, 2015, at 11:18 AM, Alana Cheng <alanac@ci.garden-grove.ca.us> wrote:

Hi all,

Please have this agreement executed and mailed back to the City.

Let me know if you have questions.

Thanks,
Alana

<Land & Design, Inc.CEQA REVIEW REIMBURSEMENT AGREEMENT
w. AECOM 7.28.15.doc>

Subject: Fwd: Restaurant Sales Tax Report
From: Greg Blodgett <greg1@ci.garden-grove.ca.us>
Date: Mon, 10 Aug 2015 16:25:27 -0700 (PDT)
To: Matthew Reid <matt.reid@landanddesign.com>

Sent from my iPhone

Begin forwarded message:

From: Grace Lee <gracel@ci.garden-grove.ca.us>
Date: August 10, 2015 at 4:09:50 PM PDT
To: "City of Garden Grove (greg1@ci.garden-grove.ca.us)" <greg1@ci.garden-grove.ca.us>
Subject: Restaurant Sales Tax Report

Grace E. Lee

Sr. Economic Development Specialist
City of Garden Grove | Economic Development Division
11222 Acacia Parkway, Garden Grove, CA 92840
Tel. 714.741.5130 | Fax (714) 741-5205

Restaurant Sales Tax Revenue.pdf	Content-Type: application/pdf Content-Encoding: base64
---	---

Part 1.1.3

Part 1.1.3	Content-Type: text/html Content-Encoding: 7bit
-------------------	---

Grove District Restaurant Sales Tax Revenue

	2002	2003	2004	2005	2006	2007	2008	2009	2010	2011	2012	2013	2014
Restaurant #1													
Restaurant #2	\$ 41,544	\$ 47,673	\$ 52,682	\$ 55,190	\$ 55,054	\$ 55,416	\$ 47,966	\$ 43,076	\$ 42,987	\$ 43,379	\$ 46,313	\$ 49,918	\$ 49,141
Restaurant #3	\$ 25,752	\$ 31,587	\$ 36,665	\$ 41,440	\$ 44,037	\$ 45,056	\$ 42,089	\$ 36,528	\$ 39,158	\$ 39,213	\$ 41,451	\$ 43,140	\$ 44,659
Restaurant #4	\$ 41,394	\$ 49,961	\$ 51,778	\$ 53,380	\$ 49,354	\$ 45,943	\$ 42,666	\$ 40,683	\$ 42,204	\$ 44,976	\$ 45,714	\$ 46,682	\$ 44,096
Restaurant #5	\$ 25,867	\$ 27,342	\$ 28,141	\$ 33,316	\$ 36,882	\$ 41,189	\$ 36,613	\$ 36,233	\$ 39,904	\$ 39,032	\$ 42,054	\$ 40,581	\$ 44,018
Restaurant #6	\$ 45,719	\$ 46,626	\$ 44,711	\$ 43,488	\$ 44,212	\$ 47,103	\$ 43,521	\$ 41,345	\$ 39,844	\$ 46,181	\$ 47,130	\$ 46,282	\$ 48,318
Restaurant #7	\$ 12,355	\$ 13,952	\$ 14,209	\$ 17,634	\$ 18,553	\$ 18,514	\$ 17,100	\$ 15,029	\$ 15,085	\$ 16,406	\$ 15,296	\$ 14,325	\$ 13,961

Grove District Restaurant Sales

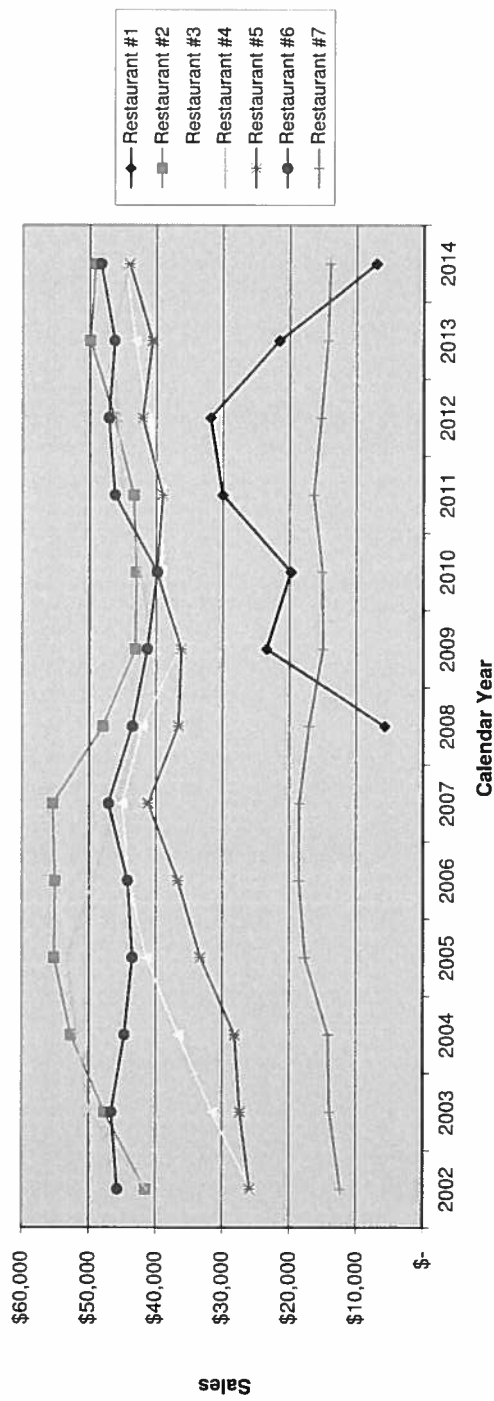

Subject: Re: Agreement for Reimbursement - Land & Design, Inc.
From: Alana Cheng <alanac@ci.garden-grove.ca.us>
Date: Wed, 12 Aug 2015 11:33:53 -0700 (PDT)
To: Matthew Reid <matt.reid@landanddesign.com>
CC: Greg Blodgett <greg1@ci.garden-grove.ca.us>, "Morgan, Jayna" <jayna.morgan@aecom.com>, Karl Hill <karlh@ci.garden-grove.ca.us>, Maria Parra <mariap@ci.garden-grove.ca.us>

Great! thank you.
I will get that for you-

alana

On Aug 12, 2015, at 11:18 AM, Matthew Reid <matt.reid@landanddesign.com> wrote:

Attached signed agreement. Original is being sent via mail.
Can you forward wire instructions for deposit?

<2015_08_12 GG reimbursmnt agremnt.pdf>

Matthew Reid

Land & Design, Inc.
3755 Avocado Blvd | #516 | LaMesa, CA 91942
858.735.1858 cell
Skype - [matthew.reid.ca](https://www.skype.com/user/matthew.reid.ca)
matt.reid@landanddesign.com

Check out our new website www.landanddesign.com

On Aug 4, 2015, at 11:18 AM, Alana Cheng <alanac@ci.garden-grove.ca.us> wrote:

Hi all,

Please have this agreement executed and mailed back to the City.

Let me know if you have questions.

Thanks,
Alana

<Land & Design, Inc.CEQA REVIEW REIMBURSEMENT AGREEMENT w. AECOM
7.28.15.doc>

**AGREEMENT FOR REIMBURSEMENT
FOR PREPARATION OF
ENVIRONMENTAL CLEARANCE DOCUMENTS**

This Agreement is made and entered into as of the 11 day of AUGUST, 2015, by and between the **City of Garden Grove** ("City") and **Land & Design, Inc.** ("Developer") (collectively referred to as the "parties").

RECITALS

- A. Developer seeks to construct a project in the City of Garden Grove; and
- B. Such project requires that environmental clearance and review be completed in compliance with the California Environmental Quality Act ("CEQA"); and
- C. City will hire a consultant to complete the required environmental review; and
- D. Developer acknowledges and agrees that the costs associated with the preparation of environmental clearance and environmental review documents are project specific costs that are the responsibility of the Developer as part of the entitlement process.

AGREEMENT

- 1. Selection of Consultant. Developer acknowledges and agrees that there is a need to hire an independent third party consultant to use his/her own professional judgment to conduct and prepare the environmental clearance and environmental review documents. City reserves the right to contract the most qualified consultant through the third party contract at the discretion of the Community Development Director ("Director").
- 2. Method of Payment. Developer shall deposit 100% of the estimated total cost of completing the environmental review prior to commencement of the environmental review. **No work shall be performed by an environmental review consultant until Developer has deposited such money with the City.** City shall keep the money deposited to complete the environmental review in a separate non-interest bearing account and will use the money to pay for the consultant's services. When the City has depleted the funds in the account, City shall immediately notify Developer of the additional funds necessary to complete the environmental review. Further, City shall notify consultant that no work should continue on the environmental review process until Developer has deposited additional funds with the City. If Developer fails to provide additional funds to the City, no further environmental review shall be completed. Developer shall be responsible for all costs incurred by the City for the consultant's services up

until the point that the City notifies the consultant to stop work on the project.

3. Administration Costs. In addition to the cost of completing the environmental review, the amounts reimbursed by Developer shall include administrative the costs incurred by City, including, without limitation, staff time, fees and services, which shall be reimbursed on a time and materials basis based on current City reimbursement rates.
4. Examination of Bills. Developer shall have the right to examine all invoices of the environmental consultant that are submitted to the City. Once Developer has made the request to review the invoices from the consultant, City shall have 10 days to copy and produce such invoices for inspection by Developer.
5. Authority of City. Because City has the ultimate authority and responsibility to prepare and review the environmental documents prior to approval of a project, City shall guide the environmental consultant as to the appropriate considerations for the review. If additional environmental or technical studies are required as a result of comments received from internal and external agencies, Developer is solely responsible for the costs of such studies. Nothing in this Agreement is meant to be a guarantee that Developer's project will be approved or that the environmental clearance will be obtained. Further, nothing in this Agreement specifies or guarantees the timing of completion of the environmental clearance and review or other related documents. The City has discretion under its police powers to approve land development projects in accordance with pertinent laws and policies.
6. Indemnity. Developer agrees to defend, indemnify and hold harmless the City, its officers, agents, employees and volunteers from and against any and all claims, demands, actions, losses, damages, injuries, and liability, direct or indirect (including any and all related costs and expenses in connection therein), arising out of the performance of this Agreement, except for any such claim arising out of the sole negligence or willful misconduct of the City, its officers, agents, employees or volunteers.
7. No Inducement. Developer declares and represents that no promise, inducement or agreement not herein expressed has been made to it and that this Agreement contains the entire agreement between and among the parties, and that the terms of this Agreement are contractual and not a mere recital. This Agreement is entered into knowingly, freely, intelligently, and voluntarily by the parties, without any duress, or coercion. The parties have had a full opportunity to review and consider the matter prior to executing this Agreement. The parties fully acknowledge that they also have had a full opportunity to discuss its contents with their respective representatives.

- 15. Termination. This Agreement may be terminated with thirty (30) days notice if Developer decides not to proceed with the proposed development project. Upon termination, Developer shall be responsible for compensation of the consultant's services performed up to the effective date of termination.
- 16. Insolvency; Receiver. Either the appointment of a receiver to take possession of all or substantially all of the assets of Developer, or a general assignment by Developer for the benefit of creditors, or any action taken or offered by Developer under any insolvency or bankruptcy action, will constitute a breach of this Agreement by Developer, and in such event this Agreement will automatically cease and terminate.
- 17. Developer Default. Should Developer fail to perform any of its obligations under this Agreement, then City may, at its option, pursue any one or more or all of the remedies available to it under this Agreement, at law or in equity. Without limiting any other remedy which may be available to it, if Developer fails to perform any of its obligations under this Agreement, City may cease performing its obligations under this Agreement and may bring an action to recover all costs and expenses incurred by the City in completing the Studies, together with interest thereon from the date incurred at the rate of 10% per annum.

IN WITNESS WHEREOF, the parties have caused this Agreement to be executed on the date first written above.

CITY:

Susan Emery
Assistant City Manager

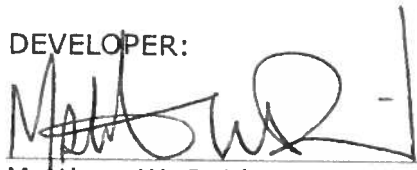
DEVELOPER:

Matthew W. Reid
President

ATTEST:

City Clerk

APPROVED AS TO FORM:

City Attorney

Subject: Re: AECOM contract and Developer Deposit Contract

From: Maria Parra <mariap@ci.garden-grove.ca.us>

Date: Thu, 13 Aug 2015 10:18:11 -0700 (PDT)

To: Jayna Morgan <Jayna.Morgan@aecom.com>

CC: Dave Rose <drose3@charter.net>, Jane Chang <Jane.Chang@aecom.com>, Khan Ziad <zkhan@langdonwilson.com>, Matthew Reid <matt.reid@landanddesign.com>

All:

We can move the meeting to 10:30 a.m.

Best Regards,

Maria Parra

Urban Planner

City of Garden Grove | Planning Services Division

11222 Acacia Parkway, Garden Grove, CA 92840

(714) 741-5312 | (714) 741-5578 fax

mariap@ci.garden-grove.ca.us | www.ci.garden-grove.ca.us

Community Development Department of the City of Garden Grove

"Providing Quality Services Through Creativity and Collaboration"

City Hall Hours:

Monday-Thursday: 7:30 a.m. to 5:30 p.m.

First Friday of the Month: 7:30 a.m. to 5:00 p.m.

Direct Website Links:

[Planning Division](#)

[Municipal Code, Title 9, Land Use](#)

[Zoning Map](#)

From: "Jayna Morgan" <Jayna.Morgan@aecom.com>

To: "Matthew Reid" <matt.reid@landanddesign.com>

Cc: "Dave Rose" <drose3@charter.net>, "Jane Chang" <Jane.Chang@aecom.com>, "Khan Ziad" <zkhan@langdonwilson.com>, "Maria Parra" <mariap@ci.garden-grove.ca.us>

Sent: Thursday, August 13, 2015 9:35:30 AM

Subject: RE: AECOM contract and Developer Deposit Contract

Thanks Matt-

Jane and I are available at 10:30, but I will let Maria reply if she can make it.

Maria- Can 10:30 instead of 11 am be arranged?

Jayna Morgan

Environmental Planner/Senior Project Manager

AECOM

999 Town & Country Road, Orange, CA 92868

T 714.567.2417 F 714.567.2760

www.aecom.com

From: Matthew Reid [mailto:matt.reid@landanddesign.com]

Sent: Thursday, August 13, 2015 9:33 AM

To: Morgan, Jayna

Cc: Dave Rose; Chang, Jane; Khan Ziad; Maria Parra

Subject: Re: AECOM contract and Developer Deposit Contract

Importance: High

Jayna,

Our meeting with the City Manager is at 9am and shouldn't go more than 1 hour. Can everyone move up 30 min to 10.30am?

Matthew Reid

Land & Design, Inc.
3755 Avocado Blvd | #516 | LaMesa, CA 91942
858.735.1858 cell
Skype - [matthew.reid.ca](https://www.skype.com/user/matthew.reid.ca)
matt.reid@landanddesign.com

Check out our new website www.landanddesign.com

On Aug 13, 2015, at 9:29 AM, Matthew Reid <matt.reid@landanddesign.com> wrote:

Terrific!
Thanks

Matthew Reid

Land & Design, Inc.
3755 Avocado Blvd | #516 | LaMesa, CA 91942
858.735.1858 cell
Skype - [matthew.reid.ca](https://www.skype.com/user/matthew.reid.ca)
matt.reid@landanddesign.com

Check out our new website www.landanddesign.com

On Aug 13, 2015, at 9:27 AM, Morgan, Jayna <Jayna.Morgan@aecom.com> wrote:

Thanks Matt!

Maria has tentatively reserved a conference room at the City at 11 am on Tuesday August 18th.
We have it on our calendars.

Best Regards-
Jayna Morgan
Environmental Planner/Senior Project Manager

AECOM
999 Town & Country Road, Orange, CA 92868
T 714.567.2417 F 714.567.2760
www.aecom.com

From: Matthew Reid [<mailto:matt.reid@landanddesign.com>]
Sent: Thursday, August 13, 2015 9:23 AM
To: Morgan, Jayna
Cc: Dave Rose; Chang, Jane; Khan Ziad
Subject: Re: AECOM contract and Developer Deposit Contract

This works for us. Let us know.

Ziad, please plan on attending....

Matthew Reid

Land & Design, Inc.
3755 Avocado Blvd | #516 | LaMesa, CA 91942
858.735.1858 cell
Skype - [matthew.reid.ca](https://www.skype.com/user/matthew.reid.ca)
matt.reid@landanddesign.com

Check out our new website www.landanddesign.com

On Aug 12, 2015, at 2:20 PM, Morgan, Jayna <Jayna.Morgan@aecom.com> wrote:

Actually, maybe we could come to the City and include Karl and/ or Maria.

I will see if one or both of them are available.

Thanks!

Jayna Morgan
Environmental Planner/Senior Project Manager

AECOM
999 Town & Country Road, Orange, CA 92868
T 714.567.2417 F 714.567.2760
www.aecom.com

From: Matthew Reid [<mailto:matt.reid@landanddesign.com>]
Sent: Wednesday, August 12, 2015 1:58 PM
To: Morgan, Jayna
Cc: Dave Rose; Chang, Jane
Subject: Re: AECOM contract and Developer Deposit Contract

No, but we are in GG on Tuesday meeting with the new City Manager. We could meet around 11am?

Matthew Reid

Land & Design, Inc.
3755 Avocado Blvd | #516 | LaMesa, CA 91942
858.735.1858 cell
Skype - [matthew.reid.ca](https://www.skype.com/user/matthew.reid.ca)
matt.reid@landanddesign.com

Check out our new website www.landanddesign.com

On Aug 12, 2015, at 1:49 PM, Morgan, Jayna <Jayna.Morgan@aecom.com> wrote:

Great News Matt! Are you guys available to meet on Monday?

Jayna Morgan
Environmental Planner/Senior Project Manager

AECOM
999 Town & Country Road, Orange, CA 92868
T 714.567.2417 F 714.567.2760
www.aecom.com

From: Matthew Reid [mailto:matt.reid@landanddesign.com]
Sent: Wednesday, August 12, 2015 1:44 PM
To: Morgan, Jayna
Cc: Dave Rose; Chang, Jane
Subject: Re: AECOM contract and Developer Deposit Contract

Thanks. We should be wiring the deposit tomorrow or Friday...

Matthew Reid
Land & Design, Inc.
3755 Avocado Blvd | #516 | LaMesa, CA 91942
858.735.1858 cell
Skype - [matthew.reid.ca](https://www.skype.com/user/matthew.reid.ca)
matt.reid@landanddesign.com

Check out our new website www.landanddesign.com

On Aug 12, 2015, at 9:54 AM, Morgan, Jayna
<Jayna.Morgan@aecom.com> wrote:

Hi Matt-

See attached for the final proposal and our signed contract with the City.
Please let us know when you will be ready to kick off this exciting project!

Best Regards-
Jayna Morgan
Environmental Planner/Senior Project Manager

AECOM
999 Town & Country Road, Orange, CA 92868
T 714.567.2417 F 714.567.2760
www.aecom.com

From: Matthew Reid [mailto:matt.reid@landanddesign.com]
Sent: Wednesday, August 12, 2015 8:25 AM
To: Morgan, Jayna
Cc: Dave Rose
Subject: Re: AECOM contract and Developer Deposit Contract

Jayna,
Can you send me your final proposal to the City for our work. I need
to cut a check in that amount as a deposit.
Thanks

Matthew Reid
Land & Design, Inc.
3755 Avocado Blvd | #516 | LaMesa, CA 91942
858.735.1858 cell
Skype - [matthew.reid.ca](https://www.skype.com/user/matthew.reid.ca)
matt.reid@landanddesign.com

Check out our new website www.landanddesign.com

On Jul 29, 2015, at 2:11 PM, Morgan, Jayna
<Jayna.Morgan@aecom.com> wrote:

Hi Matt- see attached and below. I will get out VP- Travis Taylor to sign our contract and get it back to the City by Friday/Monday at the latest. It would be great if you can do the same and we can get this kicked off next week.

Thanks so much Alana-

I will get this taken care of ASAP and hope to have the signed AECOM contract mailed back to you by Monday. I will also get in touch with Matt Reid to provide him the Developer Reimbursement contract for his signature and request the other items from him in your e-mail.

Enjoy your time off and hopefully I can get you everything you need when you are back on Monday! I will be in the office on Monday.

Kind Regards-
Jayna Morgan
Environmental Planner/Senior Project Manager
AECOM
999 Town & Country Road, Orange, CA 92868
T 714.567.2417 F 714.567.2760
www.aecom.com

From: Alana Cheng [<mailto:alanac@ci.garden-grove.ca.us>]
Sent: Wednesday, July 29, 2015 1:42 PM
To: Morgan, Jayna
Cc: Maria Parra; Karl Hill
Subject: AECOM contract and Developer Deposit Contract

Hi Jayna,

Unfortunately, our Risk Management division is pretty backed up right now. Probably because it is the beginning of the new fiscal year and all the City contracts are being renewed at once.

I have completed both the AECOM agreement and the Developer Deposit/Reimbursement Agreement. Both have been reviewed and approved by the City Attorney and I am just waiting on the sign off from Risk Management.

To speed up the process while we wait for the sign off, please review, sign, and mail back the AECOM contract attached. And if you can forward Matt the Developer Reimbursement contract for his review, signature, and have them mail that back with the updated site plan. Therefore, when both originals come back to me, I can have Susan sign them right away and we can keep move forward.

Can you ask Matt if he has an existing

insurance policy? I am sure he does, and I can just provide that to Risk Management whether they need it or not, instead of waiting for them to decide.

Thank you!

I will be off Thursday and Friday this week and be returning on Monday. Have a great weekend if I dont hear back from you until next week~

Alana

From: "Jayna Morgan" <Jayna.Morgan@aecom.com>
To: "Alana Cheng" <alanac@ci.garden-grove.ca.us>
Cc: "Maria Parra" <mariap@ci.garden-grove.ca.us>, "Karl Hill" <karlh@ci.garden-grove.ca.us>
Sent: Wednesday, July 29, 2015 12:49:03 PM
Subject: Re: Site "C"

Hi Alana and thank you so much for the update! I will wait to hear back from you and then let Matt know. I think he is meeting with the new city manager tomorrow.

Enjoy your afternoon!

Jayna Morgan
Project Manager
Sent from my iPhone

On Jul 29, 2015, at 10:37 AM, Alana Cheng <alanac@ci.garden-grove.ca.us> wrote:

hi jayna,
they wanted to see a copy of the agreement with the developer before determining if they need insurance. i sent her a copy yesterday night and waiting to hear back. ill let you know as soon as i hear back, hopefully by the end of today.
thanks!
alana

On Jul 29, 2015, at 10:12 AM, Morgan, Jayna <Jayna.Morgan@aecom.com> wrote:

Hi Alana-
Just checking with you to see if you heard back from Risk

Management?
Hope you have a great day!
Jayna Morgan
Environmental Planner/Senior
Project Manager

AECOM
999 Town & Country Road,
Orange, CA 92868
T 714.567.2417 F 714.567.2760
www.aecom.com

From: Alana Cheng
[mailto:alanac@ci.garden-grove.ca.us]
Sent: Tuesday, July 28, 2015
10:25 AM
To: Morgan, Jayna
Cc: Maria Parra; Karl Hill
Subject: Re: Site "C"

Hi Jayna,

I hope you are feeling better :(A few of coworkers here also had shingles and they were telling me how terrible it is..

The contract with AECOM and the City is pretty much done, just waiting on some attorney corrections. I am working with the City attorney on drafting up the agreement for the developer, because the verbiage needed for the deposit portion is a little bit different, so I am working on that right now. I believe I need the site plan details to include in their agreement and I might need insurance from them as well.

Let me discuss with Risk Management to verify.

Thanks!
Alana

From: "Jayna Morgan"
<Jayna.Morgan@aecom.com>
To: "Karl Hill"
<karlh@ci.garden-grove.ca.us>
Cc: "Maria Parra"

<mariap@ci.garden-grove.ca.us>, "Alana Cheng" <alanac@ci.garden-grove.ca.us>
Sent: Monday, July 27, 2015 3:31:38 PM
Subject: Fwd: Site "C"

Hi Karl,

please see below. I'm not sure if Matt has been following the email chain from his partner David.

The last email I got Dave was going to be sending some minor technical tweaks to my write up.

I also believe the Alana, city contract person, is waiting on some information from them to finalize our contracts for Susan to sign off on.

I was out the last part of the week as I got diagnosed with shingles! Very painful and I would not wish this on my worst enemy!

Please let me know if you guys are waiting on anything from Matt so that I can reply to his email.
Thank you!
Jayna Morgan
Project Manager
Sent from my iPhone

Begin forwarded message:

From: Matthew Reid
<matt.reid@landanddesign.com>
Date: July 27, 2015 at 9:42:54 AM PDT
To: "Morgan, Jayna"
<Jayna.Morgan@aecom.com>
Cc: Dave Rose
<drose3@charter.net>, David Rose
<drose3@hotmail.com>
Subject: Re: Site "C"

Good Morning

Jayna. Where
are we on this?
Are we holding
anything up?
Please let us
know....

Matthew Reid

Land & Design, Inc.
3755 Avocado
Blvd | #516 |
LaMesa, CA
91942
858.735.1858 cell
Skype -
matthew.reid.ca
matt.reid@landanddesign.com

Check out our new
website
www.landanddesign.com

On
Jul
14,
2015,
at
5:41
PM,
Morgan,
Jayna
<Jayna.Morgan@aecom.com>
wrote:

Thanks
Alana.

Have a
great
evening!

**Jayna
Morgan**
Environmental
Planner/Senior
Project
Manager

AECOM
999
Town &
Country
Road,
Orange,
CA
92868
T
714.567.2417
F
714.567.2760

www.aecom.com

From:
Alana
Cheng
[mailto:alanac@ci.garden-grove.ca.us]
Sent:
Tuesday,
July
14,
2015
5:38
PM
To:
Morgan,
Jayna
Cc:
Dave
Rose;
David
Rose;
Matthew
Reid;
Kimble,
Vivianne;
Karl
Hill;
Maria
Parra
Subject:
Re:
Site
"C"

Hi
Jayna,

Of
course,
thank
you
for
getting
the
scope
of
work
and
insurance
docs
to us
so
quickly.

Yes,
you
are
correct.

Alana
Cheng

From:
"Jayna

Morgan"
<Jayna.Morgan@aecom.com>
To:
"Alana
Cheng"
<alanac@ci.garden-grove.ca.us>,
"Karl
Hill"
<karlh@ci.garden-grove.ca.us>,
"Maria
Parra"
<mariap@ci.garden-grove.ca.us>
Cc:
"Dave
Rose"
<drose3@charter.net>,
"David
Rose"
<drose3@hotmail.com>,
"Matthew
Reid"
<matt.reid@landanddesign.com>,
"Vivianne
Kimble"
<Vivianne.Kimble@aecom.com>
Sent:
Tuesday,
July
14,
2015
4:46:13
PM
Subject:
RE:
Site
"C"

Ok,
great
Alana.
Thanks
so
much.

As I
understand
the
process,
the
contract
can be
signed
by
Susan
due to
the
small
dollar
amount.

So
there
will be
no
delay
one
you
receive
the
document
from
the
developer.

**Jayna
Morgan**
Environmental
Planner/Senior
Project
Manager

AECOM
999
Town &
Country
Road,
Orange,
CA
92868
T
714.567.2417
F
714.567.2760
www.aecom.com

From:
Alana
Cheng
[mailto:alanac@ci.garden-grove.ca.us]

Sent:
Tuesday,
July
14,
2015
4:33
PM

To:
Morgan,
Jayna;
Karl
Hill;
Maria
Parra

Cc:
Dave
Rose;
David
Rose;
Matthew
Reid

Subject:
Re:
Site
"C"

Hi
Jayna,

Yes
the
contracts
are
already
in
process,
just
waiting
on
the
documents
from
the
developer
so
we
can
process
them
concurrently.

Alana

From:
"Jayna
Morgan"
<Jayna.Morgan@aecom.com>
To:
"Matthew
Reid"
<matt.reid@landanddesign.com>
Cc:
"Dave
Rose"
<drose3@charter.net>,
"David
Rose"
<drose3@hotmail.com>,
"Alana
Cheng
(alanac@ci.garden-grove.ca.us)"
<alanac@ci.garden-grove.ca.us>
Sent:
Tuesday,
July
14,
2015
1:47:42
PM
Subject:
RE:
Site
"C"

Hi
Matt-

Good
to hear
from
you.
Regarding
your
request,
I need
to
check
with
the
City as
I
believe
that
they
will
want
us to
be
under
direct
contract
to
them
since it
is a
CEQA
addendum
document.

Also- it
will be
a very
long
contract
process
if
AECOM
has
never
contracted
with
the
entity
below.
I have
our
contract
people
checking
our
system
to see
if they
have
been a
past
client.

Also, I
believe
the

City
has
already
started
the
contract
with
them
since it
is
something
that
can be
signed
by the
Director/Susan
due to
the
small
amount.
We
already
gave
the
City
our
updated
insurance
certificates.

Alana-
please
let me
know
if the
process
has
been
started.
Thanks!
**Jayna
Morgan**
Environmental
Planner/Senior
Project
Manager

AECOM
999
Town &
Country
Road,
Orange,
CA
92868
T
714.567.2417
F
714.567.2760
www.aecom.com

From:
**Matthew
Reid**
[\[mailto:matt.reid@landanddesign.com\]](mailto:matt.reid@landanddesign.com)
Sent:

Tuesday,
July
14,
2015
8:15
AM

To:
Morgan,
Jayna

Cc:
Dave
Rose;
David
Rose

Subject:
Re:
Site
"C"

Importance:
High

Good
Morning
Jayna,

I'm
not
sure if
this
was
the
"final"
version
of
your
proposal
or not
as I
know
you
and
Dave
have
been
communicating
directly
(which
is
fine).
We
want
to get
this
process
moving,
therefore
I'll ask
that
you
revise
the
proposal
to be
addressed

to
Bainbridge
Capital
(our
JV
Partner)
with
signature
block
changes
so we
can
get
started.
We
understand
the
City
will be
the
lead
agency,
however
to
expedite
the
approval
of the
work
(and
to get
moving,
rather
than
waiting
for the
City to
draw
up a
reimbursement
agreement)
our
capital
partner
will be
the
one
signing
your
proposal.
Please
address
your
proposal
as
follows
and
resend.
We'll
get
signed
today.

Nick
Chini
Managing
Director
/
Bainbridge
Capital
4435
Eastgate
Mall,
Suite
130
San
Diego,
CA
92121

Thank
you
and let
me
know
if you
should
have
any
questions.

Thanks

**Matthew
Reid**
Land
&
Design,
Inc.
3755
Avocado
Blvd |
#516 |
LaMesa,
CA
91942
858.735.1858 cell
Skype
-
matthew.reid.ca
matt.reid@landanddesign.com

Check
out our
new
website
www.landanddesign.com

On

Jul
6,
2015,
at
3:15
PM,
Morgan,
Jayna
<Jayna.Morgan@aecom.com>
wrote:

Hi
Matt
and
David,

Hope
you
had
a
happy
and
safe
holiday.
Please
see
attached
and
below
for
the
latest
correspondence
between
me
and
the
City
regarding
the
Site
C
proposed
revisions
and
our
Scope
and
Fee
to
address
the
revisions
in
the
approved
CEQA
document.

Let
me
know
if
you

have
any
questions.

Best
Regards-
Jayna
Morgan
Environmental
Planner/Senior
Project
Manager

AECOM
999
Town
&
Country
Road,
Orange,
CA
92868
T
714.567.2417
F
714.567.2760
www.aecom.com

From:
Maria
Parra
[\[mailto:mariap@ci.garden-grove.ca.us\]](mailto:mariap@ci.garden-grove.ca.us)
Sent:
Wednesday,
July
01,
2015
9:50
AM
To:
Morgan,
Jayna
Cc:
Karl
Hill
Subject:
Re:
Site
"C"

Hi
Jayna,

I
am
okay
with
the
changes.

I
will
forward
a
copy
to
Susan,
and
to
the

City
Attorney
to
formulate
the
agreement.
Thank
you!

Best
regards,

*Maria
Parra*

Urban
Planner
City
of
Garden
Grove
|
Planning
Services
Division
11222
Acacia
Parkway,
Garden
Grove,
CA
92840
(714)
741-5312
|
(714)
741-5578
fax
[mariap@ci.garden-
grove.ca.us](mailto:mariap@ci.garden-grove.ca.us)
|
[www.ci.garden-
grove.ca.us](http://www.ci.garden-
grove.ca.us)

Community
Development
Department
of
the
City
of
Garden
Grove
*"Providing
Quality
Services
Through
Creativity
and
Collaboration"*

City
Hall
Hours:
Monday-

Thursday:
7:30
a.m.
to
5:30
p.m.
First
Friday
of
the
Month:
7:30
a.m.
to
5:00
p.m.

Direct
Website
Links:
[Planning
Division
Municipal
Code,
Title
9,
Land
Use
Zoning
Map](#)

From:
"Jayna
Morgan"
<Jayna.Morgan@aecom.com>
To:
"Maria
Parra"
<mariap@ci.garden-grove.ca.us>
Cc:
"Karl
Hill"
<karlh@ci.garden-grove.ca.us>
Sent:
Tuesday,
June
30,
2015
3:43:01
PM
Subject:
RE:
Site
"C"

Hi
Guys,

Attached
please
find
the

revised
proposal
with
your
edits
incorporated.
Let
me
know
if
you
have
any
questions
or
need
any
additional
changes.

If
I
don't
speak
with
you
before
have
a
wonderful
fourth
of
July
holiday
with
family
and
friends.

Best
Regards-
**Jayna
Morgan**
Environmental
Planner/Senior
Project
Manager

AECOM
999
Town
&
Country
Road,
Orange,
CA
92868
T
714.567.2417
F
714.567.2760
www.aecom.com

This e-mail and any attachments contain AECOM confidential information that may be proprietary or privileged. If you receive this message in error or are not the intended

recipient, you should not retain, distribute, disclose or use any of this information and you should destroy the e-mail and any attachments or copies.

<Addendum
Proposal
-
Hotel
Site
C.pdf><Mail
Attachment.eml>

<Land & Design, Inc.CEQA REVIEW
REIMBURSEMENT AGREEMENT w. AECOM
7.28.15.doc>

<Addendum Proposal - Hotel Site C.pdf><signed.SiteC.
Agreement(1).pdf>

Subject: RE: Agreement for Reimbursement - Land & Design, Inc.

From: "Morgan, Jayna" <Jayna.Morgan@aecom.com>

Date: Fri, 14 Aug 2015 00:10:02 +0000

To: Alana Cheng <alanac@ci.garden-grove.ca.us>, Matthew Reid <matt.reid@landanddesign.com>

CC: Greg Blodgett <greg1@ci.garden-grove.ca.us>, Karl Hill <karlh@ci.garden-grove.ca.us>, Maria Parra <mariap@ci.garden-grove.ca.us>, Susan Emery <susan1@ci.garden-grove.ca.us>

Thank you Alana!

Maria has set up a meeting Tuesday at 10:30 to discuss the Addendum MND, since Matt will be here.

Susan- Congratulations on the new job.... What a great opportunity, but I know you will be missed in GG!

Have a great weekend for those who are off tomorrow!

Jayna Morgan

Environmental Planner/Senior Project Manager

AECOM

999 Town & Country Road, Orange, CA 92868

T 714.567.2417 F 714.567.2760

www.aecom.com

From: Alana Cheng [mailto:alanac@ci.garden-grove.ca.us]

Sent: Thursday, August 13, 2015 5:05 PM

To: Matthew Reid

Cc: Greg Blodgett; Morgan, Jayna; Karl Hill; Maria Parra; Susan Emery

Subject: Re: Agreement for Reimbursement - Land & Design, Inc.

Hi Matt,

Please find wiring instructions below:

Union Bank

ABA#: [REDACTED]

Credit to Account #: [REDACTED]

Account Name: City of Garden Grove - General Account

Beneficiary / Payee: City of Garden Grove

OBI: **Please see note below.**

**** Please add the description for the deposit : Site "C" CONSULTANT REIMBURSEMENT so we can identify the money when it comes in.**

Thank you,

Alana

From: "Matthew Reid" <matt.reid@landanddesign.com>

To: "Alana Cheng" <alanac@ci.garden-grove.ca.us>
Cc: "Greg Blodgett" <greg1@ci.garden-grove.ca.us>, "Jayna Morgan" <jayna.morgan@aecom.com>, "Karl Hill" <karlh@ci.garden-grove.ca.us>, "Maria Parra" <mariap@ci.garden-grove.ca.us>
Sent: Wednesday, August 12, 2015 11:14:11 AM
Subject: Re: Agreement for Reimbursement - Land & Design, Inc.

Attached signed agreement. Original is being sent via mail.
Can you forward wire instructions for deposit?

Matthew Reid

Land & Design, Inc.
3755 Avocado Blvd | #516 | LaMesa, CA 91942
858.735.1858 cell
Skype - [matthew.reid.ca](https://www.skype.com/user/matthew.reid.ca)
matt.reid@landanddesign.com

Check out our new website www.landanddesign.com

On Aug 4, 2015, at 11:18 AM, Alana Cheng <alanac@ci.garden-grove.ca.us> wrote:

Hi all,

Please have this agreement executed and mailed back to the City.

Let me know if you have questions.

Thanks,

Alana

<Land & Design, Inc.CEQA REVIEW REIMBURSEMENT AGREEMENT w. AECOM 7.28.15.doc>

Subject: Re: Agreement for Reimbursement - Land & Design, Inc.
From: Alana Cheng <alanac@ci.garden-grove.ca.us>
Date: Mon, 17 Aug 2015 10:45:44 -0700 (PDT)
To: Matthew Reid <matt.reid@landanddesign.com>
CC: Greg Blodgett <greg1@ci.garden-grove.ca.us>, Jayna Morgan <jayna.morgan@aecom.com>, Maria Parra <mariap@ci.garden-grove.ca.us>

Thank you very much Matt.

Alana

From: "Matthew Reid" <matt.reid@landanddesign.com>
To: "Alana Cheng" <alanac@ci.garden-grove.ca.us>
Cc: "Greg Blodgett" <greg1@ci.garden-grove.ca.us>, "Jayna Morgan" <jayna.morgan@aecom.com>, "Maria Parra" <mariap@ci.garden-grove.ca.us>
Sent: Monday, August 17, 2015 10:42:37 AM
Subject: Re: Agreement for Reimbursement - Land & Design, Inc.

Agreement was put in the mail, a day or two and should be in your hands.
I'll verify with our partner the wire has been sent....

Matthew Reid

Land & Design, Inc.
3755 Avocado Blvd | #516 | LaMesa, CA 91942
858.735.1858 cell
Skype - [matthew.reid.ca](https://www.skype.com/user/matthew.reid.ca)
matt.reid@landanddesign.com

Check out our new website www.landanddesign.com

On Aug 17, 2015, at 10:40 AM, Alana Cheng <alanac@ci.garden-grove.ca.us> wrote:

Hi Matt,

Please let me know if you wired the deposit on Friday so I can ask our Finance Department to verify. AECOM is coming tomorrow morning to meet with Maria. Also, I still have not received your original executed agreement.

Thank you,

Alana

From: "Alana Cheng" <alanac@ci.garden-grove.ca.us>
To: "Matthew Reid" <matt.reid@landanddesign.com>
Cc: "Greg Blodgett" <greg1@ci.garden-grove.ca.us>, "Jayna Morgan" <jayna.morgan@aecom.com>, "Karl Hill" <karlh@ci.garden-grove.ca.us>, "Maria Parra" <mariap@ci.garden-grove.ca.us>, "Susan Emery" <susan1@ci.garden-grove.ca.us>
Sent: Thursday, August 13, 2015 5:05:02 PM
Subject: Re: Agreement for Reimbursement - Land & Design, Inc.

Hi Matt,

Please find wiring instructions below:

Union Bank
ABA#: [REDACTED]
Credit to Account #: [REDACTED]
Account Name: City of Garden Grove - General Account
Beneficiary / Payee: City of Garden Grove
OBI: **Please see note below.**

** Please add the description for the deposit : **Site "C" CONSULTANT REIMBURSEMENT** so we can identify the money when it comes in.

Thank you,

Alana

From: "Matthew Reid" <matt.reid@landanddesign.com>
To: "Alana Cheng" <alanac@ci.garden-grove.ca.us>
Cc: "Greg Blodgett" <greg1@ci.garden-grove.ca.us>, "Jayna Morgan" <jayna.morgan@aecom.com>, "Karl Hill" <karlh@ci.garden-grove.ca.us>, "Maria Parra" <mariap@ci.garden-grove.ca.us>
Sent: Wednesday, August 12, 2015 11:14:11 AM
Subject: Re: Agreement for Reimbursement - Land & Design, Inc.

Attached signed agreement. Original is being sent via mail.
Can you forward wire instructions for deposit?

Matthew Reid

Land & Design, Inc.

3755 Avocado Blvd | #516 | LaMesa, CA 91942

858.735.1858 cell

Skype - [matthew.reid.ca](https://www.skype.com/user/matthew.reid.ca)

matt.reid@landanddesign.com

Check out our new website www.landanddesign.com

On Aug 4, 2015, at 11:18 AM, Alana Cheng <alanac@ci.garden-grove.ca.us> wrote:

Hi all,

Please have this agreement executed and mailed back to the City.

Let me know if you have questions.

Thanks,

Alana

<Land & Design, Inc.CEQA REVIEW REIMBURSEMENT AGREEMENT
w. AECOM 7.28.15.doc>

Subject: Re: Agreement for Reimbursement - Land & Design, Inc.
From: Maria Parra <mariap@ci.garden-grove.ca.us>
Date: Mon, 17 Aug 2015 11:32:48 -0700 (PDT)
To: Alana Cheng <alanac@ci.garden-grove.ca.us>
CC: Greg Blodgett <greg1@ci.garden-grove.ca.us>, Jayna Morgan <jayna.morgan@aecom.com>, Matthew Reid <matt.reid@landanddesign.com>

Hi All:

The meeting for tomorrow is tentative until I receive confirmation that we can move forward based on the City receiving the executed agreements and deposits, as these are still outstanding.

Best regards,

Maria Parra

Urban Planner
City of Garden Grove | Planning Services Division
11222 Acacia Parkway, Garden Grove, CA 92840
(714) 741-5312 | (714) 741-5578 fax
mariap@ci.garden-grove.ca.us | www.ci.garden-grove.ca.us

Community Development Department of the City of Garden Grove
"Providing Quality Services Through Creativity and Collaboration"

City Hall Hours:
Monday-Thursday: 7:30 a.m. to 5:30 p.m.
First Friday of the Month: 7:30 a.m. to 5:00 p.m.

Direct Website Links:
[Planning Division](#)
[Municipal Code, Title 9, Land Use](#)
[Zoning Map](#)

From: "Alana Cheng" <alanac@ci.garden-grove.ca.us>
To: "Matthew Reid" <matt.reid@landanddesign.com>
Cc: "Greg Blodgett" <greg1@ci.garden-grove.ca.us>, "Jayna Morgan" <jayna.morgan@aecom.com>, "Maria Parra" <mariap@ci.garden-grove.ca.us>
Sent: Monday, August 17, 2015 10:40:25 AM
Subject: Re: Agreement for Reimbursement - Land & Design, Inc.

Hi Matt,

Please let me know if you wired the deposit on Friday so I can ask our Finance Department to verify. AECOM is coming tomorrow morning to meet with Maria. Also, I still have not received your original executed agreement.

Thank you,

Alana

From: "Alana Cheng" <alanac@ci.garden-grove.ca.us>
To: "Matthew Reid" <matt.reid@landanddesign.com>
Cc: "Greg Blodgett" <greg1@ci.garden-grove.ca.us>, "Jayna Morgan" <jayna.morgan@aecom.com>, "Karl Hill" <karlh@ci.garden-grove.ca.us>, "Maria Parra" <mariap@ci.garden-grove.ca.us>, "Susan Emery" <susan1@ci.garden-grove.ca.us>
Sent: Thursday, August 13, 2015 5:05:02 PM
Subject: Re: Agreement for Reimbursement - Land & Design, Inc.

Hi Matt,

Please find wiring instructions below:

Union Bank
ABA#: [REDACTED]
Credit to Account #: [REDACTED]
Account Name: City of Garden Grove - General Account
Beneficiary / Payee: City of Garden Grove
OBI: **Please see note below.**

** Please add the description for the deposit : **Site "C" CONSULTANT REIMBURSEMENT** so we can identify the money when it comes in.

Thank you,

Alana

From: "Matthew Reid" <matt.reid@landanddesign.com>
To: "Alana Cheng" <alanac@ci.garden-grove.ca.us>
Cc: "Greg Blodgett" <greg1@ci.garden-grove.ca.us>, "Jayna Morgan" <jayna.morgan@aecom.com>, "Karl Hill" <karlh@ci.garden-grove.ca.us>, "Maria Parra" <mariap@ci.garden-grove.ca.us>
Sent: Wednesday, August 12, 2015 11:14:11 AM
Subject: Re: Agreement for Reimbursement - Land & Design, Inc.

Attached signed agreement. Original is being sent via mail.
Can you forward wire instructions for deposit?

Matthew Reid

Land & Design, Inc.

3755 Avocado Blvd | #516 | LaMesa, CA 91942

858.735.1858 cell

Skype - [matthew.reid.ca](https://www.skype.com/people/matthew.reid.ca)

matt.reid@landanddesign.com

Check out our new website www.landanddesign.com

On Aug 4, 2015, at 11:18 AM, Alana Cheng <alanac@ci.garden-grove.ca.us> wrote:

Hi all,

Please have this agreement executed and mailed back to the City.

Let me know if you have questions.

Thanks,

Alana

<Land & Design, Inc.CEQA REVIEW REIMBURSEMENT AGREEMENT w. AECOM
7.28.15.doc>

Subject: Agenda for today's meeting
From: Matthew Reid <matt.reid@landanddesign.com>
Date: Tue, 18 Aug 2015 06:57:27 -0700
To: Greg Blodgett <Greg1@ci.garden-grove.ca.us>
CC: Dave Rose <drose3@charter.net>

Greg,
Here is an agenda for today....

Matthew Reid
Land & Design, Inc.
3755 Avocado Blvd | #516 | LaMesa, CA 91942
858.735.1858 cell
Skype - [matthew.reid.ca](https://www.skype.com/people/matthew.reid.ca)
matt.reid@landanddesign.com

Check out our new website www.landanddesign.com

2015_08_18 City agenda.docx	Content-Type: application/vnd.openxmlformats-officedocument.wordprocessingml.document Content-Encoding: base64
------------------------------------	---

Part 1.1.3

Part 1.1.3	Content-Type: text/html Content-Encoding: quoted-printable
-------------------	---

**CITY OF GARDEN GROVE / LAND & DESIGN, INC.
NEW CITY MANAGER MEETING
Tuesday, August 18, 2015 | 9:00am**

AGENDA

- Introduction of development principals
- Review of project status
 - Site Plan update
 - Entitlements update
 - Flag update
 - Budget update \$450M
- Status of RDA proposal to LND (Tom Clark)?
- Status of City getting land control?
 - Remaining house
 - Eviction of Joes Italian Ice? Agreements?
- Will serve letters from water districts never received?
- City obligations under the agreement
 - Clearing site
 - Removing utilities – could delay the project

Subject: Re: Agreement for Reimbursement - Land & Design, Inc.
From: Matthew Reid <matt.reid@landanddesign.com>
Date: Tue, 18 Aug 2015 08:34:46 -0700
To: Alana Cheng <alanac@ci.garden-grove.ca.us>
CC: Greg Blodgett <greg1@ci.garden-grove.ca.us>, Jayna Morgan <jayna.morgan@aecom.com>, Maria Parra <mariap@ci.garden-grove.ca.us>, Nick Chini <nchini@bainbridge.com>, Andrea Morgan <amorgan@bainbridge.com>

Yes, wire is in process....

Sent from my iPhone

Matthew Reid

Land & Design, Inc.

3755 Avocado Blvd | #516 | LaMesa, CA 91941

619.567.2447 x101 **office**

858.735.1858 **cell**

619.489.3669 **efax**

Skype - [matthew.reid.ca](https://www.skype.com/people/matthew.reid.ca)

matt.reid@landanddesign.com

Check out our new website www.landanddesign.com

On Aug 18, 2015, at 8:31 AM, Alana Cheng <alanac@ci.garden-grove.ca.us> wrote:

Good Morning Matt,

I just received the original agreement this morning. Did you have a chance to verify with your partner that the wire has been sent? Please let me know when you can.

Thanks,
Alana

From: "Matthew Reid" <matt.reid@landanddesign.com>
To: "Alana Cheng" <alanac@ci.garden-grove.ca.us>
Cc: "Greg Blodgett" <greg1@ci.garden-grove.ca.us>, "Jayna Morgan" <jayna.morgan@aecom.com>, "Maria Parra" <mariap@ci.garden-grove.ca.us>
Sent: Monday, August 17, 2015 10:42:37 AM
Subject: Re: Agreement for Reimbursement - Land & Design, Inc.

Agreement was put in the mail, a day or two and should be in your hands.
I'll verify with our partner the wire has been sent....

Matthew Reid

Land & Design, Inc.

3755 Avocado Blvd | #516 | LaMesa, CA 91942

858.735.1858 **cell**

Skype - matthew.reid.ca
matt.reid@landanddesign.com

Check out our new website www.landanddesign.com

On Aug 17, 2015, at 10:40 AM, Alana Cheng <alanac@ci.garden-grove.ca.us> wrote:

Hi Matt,

Please let me know if you wired the deposit on Friday so I can ask our Finance Department to verify. AECOM is coming tomorrow morning to meet with Maria. Also, I still have not received your original executed agreement.

Thank you,

Alana

From: "Alana Cheng" <alanac@ci.garden-grove.ca.us>
To: "Matthew Reid" <matt.reid@landanddesign.com>
Cc: "Greg Blodgett" <greg1@ci.garden-grove.ca.us>, "Jayna Morgan" <jayna.morgan@aecom.com>, "Karl Hill" <karlh@ci.garden-grove.ca.us>, "Maria Parra" <mariap@ci.garden-grove.ca.us>, "Susan Emery" <susan1@ci.garden-grove.ca.us>
Sent: Thursday, August 13, 2015 5:05:02 PM
Subject: Re: Agreement for Reimbursement - Land & Design, Inc.

Hi Matt,

Please find wiring instructions below:

Union Bank

ABA#: [REDACTED]

Credit to Account #: [REDACTED]

Account Name: City of Garden Grove - General Account

Beneficiary / Payee: City of Garden Grove

OBI: **Please see note below.**

**** Please add the description for the deposit : Site "C" CONSULTANT REIMBURSEMENT so we can identify the money when it comes in.**

Thank you,

Alana

From: "Matthew Reid" <matt.reid@landanddesign.com>
To: "Alana Cheng" <alanac@ci.garden-grove.ca.us>
Cc: "Greg Blodgett" <greg1@ci.garden-grove.ca.us>, "Jayna Morgan" <jayna.morgan@aecom.com>, "Karl Hill" <karlh@ci.garden-grove.ca.us>, "Maria Parra" <mariap@ci.garden-grove.ca.us>
Sent: Wednesday, August 12, 2015 11:14:11 AM
Subject: Re: Agreement for Reimbursement - Land & Design, Inc.

Attached signed agreement. Original is being sent via mail.
Can you forward wire instructions for deposit?

Matthew Reid

Land & Design, Inc.
3755 Avocado Blvd | #516 | LaMesa, CA 91942
858.735.1858 cell
Skype - [matthew.reid.ca](https://www.skype.com/user/matthew.reid.ca)
matt.reid@landanddesign.com

Check out our new website www.landanddesign.com

On Aug 4, 2015, at 11:18 AM, Alana Cheng <alanac@ci.garden-grove.ca.us> wrote:

Hi all,

Please have this agreement executed and mailed back to the City.

Let me know if you have questions.

Thanks,

Alana
<Land & Design, Inc.CEQA REVIEW REIMBURSEMENT
AGREEMENT w. AECOM 7.28.15.doc>

Subject: Re: Agreement for Reimbursement - Land & Design, Inc.
From: "Morgan, Jayna" <Jayna.Morgan@aecom.com>
Date: Tue, 18 Aug 2015 15:37:27 +0000
To: Alana Cheng <alanac@ci.garden-grove.ca.us>
CC: Matthew Reid <matt.reid@landanddesign.com>, Greg Blodgett <greg1@ci.garden-grove.ca.us>, Maria Parra <mariap@ci.garden-grove.ca.us>

Thank you!

Please let us know ASAP.

I spoke with Maria last night and she does not want to hold the meeting until the deposit is with the city.

Best regards,

Jayna Morgan

Project Manager

Sent from my iPhone

On Aug 18, 2015, at 8:32 AM, Alana Cheng <alanac@ci.garden-grove.ca.us> wrote:

Good Morning Matt,

I just received the original agreement this morning. Did you have a chance to verify with your partner that the wire has been sent? Please let me know when you can.

Thanks,
Alana

From: "Matthew Reid" <matt.reid@landanddesign.com>
To: "Alana Cheng" <alanac@ci.garden-grove.ca.us>
Cc: "Greg Blodgett" <greg1@ci.garden-grove.ca.us>, "Jayna Morgan" <jayna.morgan@aecom.com>, "Maria Parra" <mariap@ci.garden-grove.ca.us>
Sent: Monday, August 17, 2015 10:42:37 AM
Subject: Re: Agreement for Reimbursement - Land & Design, Inc.

Agreement was put in the mail, a day or two and should be in your hands.
I'll verify with our partner the wire has been sent....

Matthew Reid

Land & Design, Inc.

3755 Avocado Blvd | #516 | LaMesa, CA 91942

858.735.1858 cell

Skype - [matthew.reid.ca](https://www.skype.com/user/matthew.reid.ca)

matt.reid@landanddesign.com

Check out our new website www.landanddesign.com

On Aug 17, 2015, at 10:40 AM, Alana Cheng <alanac@ci.garden-grove.ca.us> wrote:

Hi Matt,

Please let me know if you wired the deposit on Friday so I can ask our Finance Department to verify. AECOM is coming tomorrow morning to meet with Maria. Also, I still have not received your original executed agreement.

Thank you,

Alana

From: "Alana Cheng" <alanac@ci.garden-grove.ca.us>
To: "Matthew Reid" <matt.reid@landanddesign.com>
Cc: "Greg Blodgett" <greg1@ci.garden-grove.ca.us>, "Jayna Morgan" <jayna.morgan@aecom.com>, "Karl Hill" <karlh@ci.garden-grove.ca.us>, "Maria Parra" <mariap@ci.garden-grove.ca.us>, "Susan Emery" <susan1@ci.garden-grove.ca.us>
Sent: Thursday, August 13, 2015 5:05:02 PM
Subject: Re: Agreement for Reimbursement - Land & Design, Inc.

Hi Matt,

Please find wiring instructions below:

Union Bank

ABA#: [REDACTED]

Credit to Account #: [REDACTED]

Account Name: City of Garden Grove - General Account

Beneficiary / Payee: City of Garden Grove

OBI: **Please see note below.**

** Please add the description for the deposit : **Site "C" CONSULTANT REIMBURSEMENT** so we can identify the money when it comes in.

Thank you,

Alana

From: "Matthew Reid" <matt.reid@landanddesign.com>
To: "Alana Cheng" <alanac@ci.garden-grove.ca.us>
Cc: "Greg Blodgett" <greg1@ci.garden-grove.ca.us>, "Jayna Morgan" <jayna.morgan@aecom.com>, "Karl Hill" <karlh@ci.garden-grove.ca.us>, "Maria Parra" <mariap@ci.garden-grove.ca.us>
Sent: Wednesday, August 12, 2015 11:14:11 AM
Subject: Re: Agreement for Reimbursement - Land & Design, Inc.

Attached signed agreement. Original is being sent via mail.
Can you forward wire instructions for deposit?

Matthew Reid

Land & Design, Inc.
3755 Avocado Blvd | #516 | LaMesa, CA 91942
858.735.1858 cell
Skype - [matthew.reid.ca](https://www.skype.com/user/matthew.reid.ca)
matt.reid@landanddesign.com

Check out our new website www.landanddesign.com

On Aug 4, 2015, at 11:18 AM, Alana Cheng <alanac@ci.garden-grove.ca.us> wrote:

Hi all,

Please have this agreement executed and mailed back to the City.

Let me know if you have questions.

Thanks,
Alana
<Land & Design, Inc.CEQA REVIEW REIMBURSEMENT AGREEMENT w. AECOM 7.28.15.doc>

Subject: Re: Agreement for Reimbursement - Land & Design, Inc.
From: Matthew Reid <matt.reid@landanddesign.com>
Date: Tue, 18 Aug 2015 08:41:49 -0700
To: "Morgan, Jayna" <Jayna.Morgan@aecom.com>
CC: Alana Cheng <alanac@ci.garden-grove.ca.us>, Greg Blodgett <greg1@ci.garden-grove.ca.us>, Maria Parra <mariap@ci.garden-grove.ca.us>

Greg?

Sent from my iPhone

Matthew Reid

Land & Design, Inc.

3755 Avocado Blvd | #516 | LaMesa, CA 91941

619.567.2447 x101 **office**

858.735.1858 **cell**

619.489.3669 **efax**

Skype - [matthew.reid.ca](https://www.skype.com/people/matthew.reid.ca)

matt.reid@landanddesign.com

Check out our new website www.landanddesign.com

On Aug 18, 2015, at 8:37 AM, Morgan, Jayna <Jayna.Morgan@aecom.com> wrote:

Thank you!

Please let us know ASAP.

I spoke with Maria last night and she does not want to hold the meeting until the deposit is with the city.

Best regards,

Jayna Morgan

Project Manager

Sent from my iPhone

On Aug 18, 2015, at 8:32 AM, Alana Cheng <alanac@ci.garden-grove.ca.us> wrote:

Good Morning Matt,

I just received the original agreement this morning. Did you have a chance to verify with your partner that the wire has been sent? Please let me know when you can.

Thanks,

Alana

From: "Matthew Reid" <matt.reid@landanddesign.com>

To: "Alana Cheng" <alanac@ci.garden-grove.ca.us>

Cc: "Greg Blodgett" <greg1@ci.garden-grove.ca.us>, "Jayna Morgan"

<jayna.morgan@aecom.com>, "Maria Parra" <mariap@ci.garden-grove.ca.us>

Sent: Monday, August 17, 2015 10:42:37 AM

Subject: Re: Agreement for Reimbursement - Land & Design, Inc.

Agreement was put in the mail, a day or two and should be in your hands.
I'll verify with our partner the wire has been sent....

Matthew Reid

Land & Design, Inc.

3755 Avocado Blvd | #516 | LaMesa, CA 91942

858.735.1858 cell

Skype - [matthew.reid.ca](https://www.skype.com/user/matthew.reid.ca)

matt.reid@landanddesign.com

Check out our new website www.landanddesign.com

On Aug 17, 2015, at 10:40 AM, Alana Cheng <alanac@ci.garden-grove.ca.us> wrote:

Hi Matt,

Please let me know if you wired the deposit on Friday so I can ask our Finance Department to verify. AECOM is coming tomorrow morning to meet with Maria. Also, I still have not received your original executed agreement.

Thank you,

Alana

From: "Alana Cheng" <alanac@ci.garden-grove.ca.us>

To: "Matthew Reid" <matt.reid@landanddesign.com>

Cc: "Greg Blodgett" <greg1@ci.garden-grove.ca.us>, "Jayna Morgan" <jayna.morgan@aecom.com>, "Karl Hill" <karlh@ci.garden-grove.ca.us>, "Maria Parra" <mariap@ci.garden-grove.ca.us>, "Susan Emery" <susan1@ci.garden-grove.ca.us>

Sent: Thursday, August 13, 2015 5:05:02 PM

Subject: Re: Agreement for Reimbursement - Land & Design, Inc.

Hi Matt,

Please find wiring instructions below:

Union Bank

ABA#: [REDACTED]

Credit to Account #: [REDACTED]

Account Name: City of Garden Grove - General Account

Beneficiary / Payee: City of Garden Grove

OBI: **Please see note below.**

** Please add the description for the deposit : **Site "C" CONSULTANT REIMBURSEMENT** so we can identify the money when it comes in.

Thank you,

Alana

From: "Matthew Reid" <matt.reid@landanddesign.com>
To: "Alana Cheng" <alanac@ci.garden-grove.ca.us>
Cc: "Greg Blodgett" <greg1@ci.garden-grove.ca.us>, "Jayna Morgan" <jayna.morgan@aecom.com>, "Karl Hill" <karlh@ci.garden-grove.ca.us>, "Maria Parra" <mariap@ci.garden-grove.ca.us>
Sent: Wednesday, August 12, 2015 11:14:11 AM
Subject: Re: Agreement for Reimbursement - Land & Design, Inc.

Attached signed agreement. Original is being sent via mail.
Can you forward wire instructions for deposit?

Matthew Reid

Land & Design, Inc.

3755 Avocado Blvd | #516 | LaMesa, CA 91942

858.735.1858 cell

Skype - [matthew.reid.ca](https://www.skype.com/user/matthew.reid.ca)

matt.reid@landanddesign.com

Check out our new website www.landanddesign.com

On Aug 4, 2015, at 11:18 AM, Alana Cheng <alanac@ci.garden-grove.ca.us> wrote:

Hi all,

Please have this agreement executed and mailed back to the City.

Let me know if you have questions.

Thanks,

Alana

<Land & Design, Inc.CEQA REVIEW REIMBURSEMENT AGREEMENT w. AECOM 7.28.15.doc>

Subject: Re: Agreement for Reimbursement - Land & Design, Inc.
From: Matthew Reid <matt.reid@landanddesign.com>
Date: Tue, 18 Aug 2015 08:46:50 -0700
To: "Morgan, Jayna" <Jayna.Morgan@aecom.com>
CC: Alana Cheng <alanac@ci.garden-grove.ca.us>, Greg Blodgett <greg1@ci.garden-grove.ca.us>, Maria Parra <mariap@ci.garden-grove.ca.us>

The wire is in process and our Arch is coming. We should meet regardless...

Sent from my iPhone

Matthew Reid

Land & Design, Inc.

3755 Avocado Blvd | #516 | LaMesa, CA 91941

619.567.2447 x101 **office**

858.735.1858 **cell**

619.489.3669 **efax**

Skype - [matthew.reid.ca](https://www.skype.com/people/matthew.reid.ca)

matt.reid@landanddesign.com

Check out our new website www.landanddesign.com

On Aug 18, 2015, at 8:37 AM, Morgan, Jayna <Jayna.Morgan@aecom.com> wrote:

Thank you!

Please let us know ASAP.

I spoke with Maria last night and she does not want to hold the meeting until the deposit is with the city.

Best regards,

Jayna Morgan

Project Manager

Sent from my iPhone

On Aug 18, 2015, at 8:32 AM, Alana Cheng <alanac@ci.garden-grove.ca.us> wrote:

Good Morning Matt,

I just received the original agreement this morning. Did you have a chance to verify with your partner that the wire has been sent? Please let me know when you can.

Thanks,

Alana

From: "Matthew Reid" <matt.reid@landanddesign.com>

To: "Alana Cheng" <alanac@ci.garden-grove.ca.us>

Cc: "Greg Blodgett" <greg1@ci.garden-grove.ca.us>, "Jayna Morgan"

<jayna.morgan@aecom.com>, "Maria Parra" <mariap@ci.garden-grove.ca.us>

Sent: Monday, August 17, 2015 10:42:37 AM

Subject: Re: Agreement for Reimbursement - Land & Design, Inc.

Agreement was put in the mail, a day or two and should be in your hands.
I'll verify with our partner the wire has been sent....

Matthew Reid

Land & Design, Inc.

3755 Avocado Blvd | #516 | LaMesa, CA 91942

858.735.1858 cell

Skype - [matthew.reid.ca](https://www.skype.com/people/matthew.reid.ca)

matt.reid@landanddesign.com

Check out our new website www.landanddesign.com

On Aug 17, 2015, at 10:40 AM, Alana Cheng <alanac@ci.garden-grove.ca.us> wrote:

Hi Matt,

Please let me know if you wired the deposit on Friday so I can ask our Finance Department to verify. AECOM is coming tomorrow morning to meet with Maria. Also, I still have not received your original executed agreement.

Thank you,

Alana

From: "Alana Cheng" <alanac@ci.garden-grove.ca.us>

To: "Matthew Reid" <matt.reid@landanddesign.com>

Cc: "Greg Blodgett" <greg1@ci.garden-grove.ca.us>, "Jayna Morgan" <jayna.morgan@aecom.com>, "Karl Hill" <karlh@ci.garden-grove.ca.us>, "Maria Parra" <mariap@ci.garden-grove.ca.us>, "Susan Emery" <susan1@ci.garden-grove.ca.us>

Sent: Thursday, August 13, 2015 5:05:02 PM

Subject: Re: Agreement for Reimbursement - Land & Design, Inc.

Hi Matt,

Please find wiring instructions below:

Union Bank

ABA#: [REDACTED]

Credit to Account #: [REDACTED]

Account Name: City of Garden Grove - General Account

Beneficiary / Payee: City of Garden Grove

OBI: **Please see note below.**

** Please add the description for the deposit : **Site "C" CONSULTANT REIMBURSEMENT** so we can identify the money when it comes in.

Thank you,

Alana

From: "Matthew Reid" <matt.reid@landanddesign.com>

To: "Alana Cheng" <alanac@ci.garden-grove.ca.us>

Cc: "Greg Blodgett" <greg1@ci.garden-grove.ca.us>, "Jayna Morgan" <jayna.morgan@aecom.com>, "Karl Hill" <karlh@ci.garden-grove.ca.us>, "Maria Parra" <mariap@ci.garden-grove.ca.us>

Sent: Wednesday, August 12, 2015 11:14:11 AM

Subject: Re: Agreement for Reimbursement - Land & Design, Inc.

Attached signed agreement. Original is being sent via mail.
Can you forward wire instructions for deposit?

Matthew Reid

Land & Design, Inc.

3755 Avocado Blvd | #516 | LaMesa, CA 91942

858.735.1858 **cell**

Skype - [matthew.reid.ca](https://www.skype.com/user/matthew.reid.ca)

matt.reid@landanddesign.com

Check out our new website www.landanddesign.com

On Aug 4, 2015, at 11:18 AM, Alana Cheng <alanac@ci.garden-grove.ca.us> wrote:

Hi all,

Please have this agreement executed and mailed back to the City.

Let me know if you have questions.

Thanks,

Alana

<Land & Design, Inc.CEQA REVIEW REIMBURSEMENT AGREEMENT w. AECOM 7.28.15.doc>

Subject: LWI-HR-GG-Progress 081415
From: "Matthew Reid (Land & Design)" <matt.reid@landanddesign.com>
Date: Tue, 18 Aug 2015 09:03:08 -0700
To: Greg Blodgett <greg1@ci.garden-grove.ca.us>

Sent from my iPad

Matthew W Reid
Land & Design, Inc.
3755 Avocado Blvd, Suite 516
La Mesa, CA. 91941
858.735.1858 c
619.489.3669 efax
Skype - [matthew.reid.ca](https://www.skype.com/people/matthew.reid.ca)

LWI-HR-GG-Progress 081415.pdf	Content-Type: application/pdf Content-Encoding: base64
--------------------------------------	---

-- Part 1.1.3 --

Part 1.1.3	Content-Type: text/html Content-Encoding: 7bit
-------------------	---

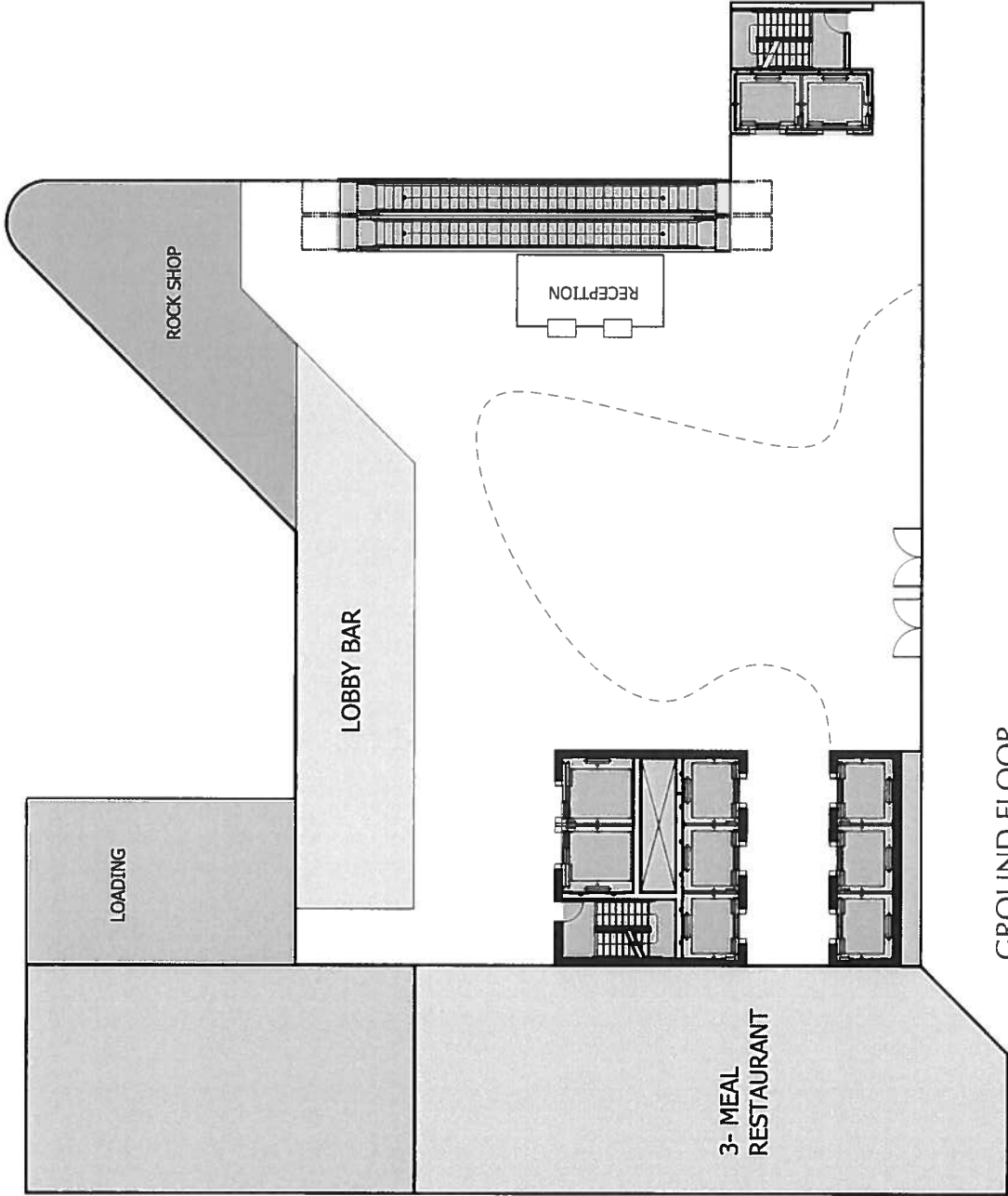

GROUND FLOOR
AREA: 17,267 sf

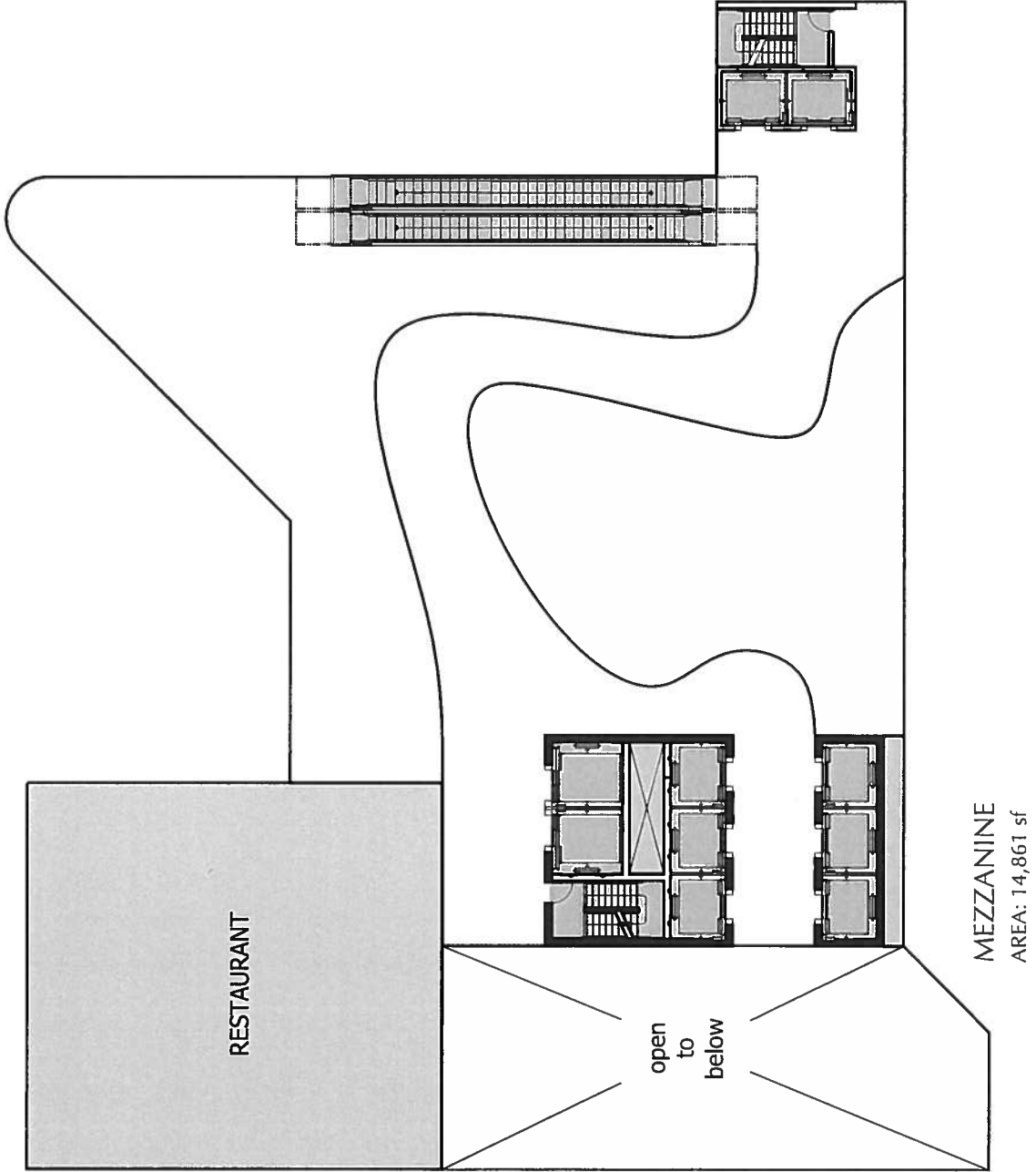

MEZZANINE
AREA: 14,861 sf

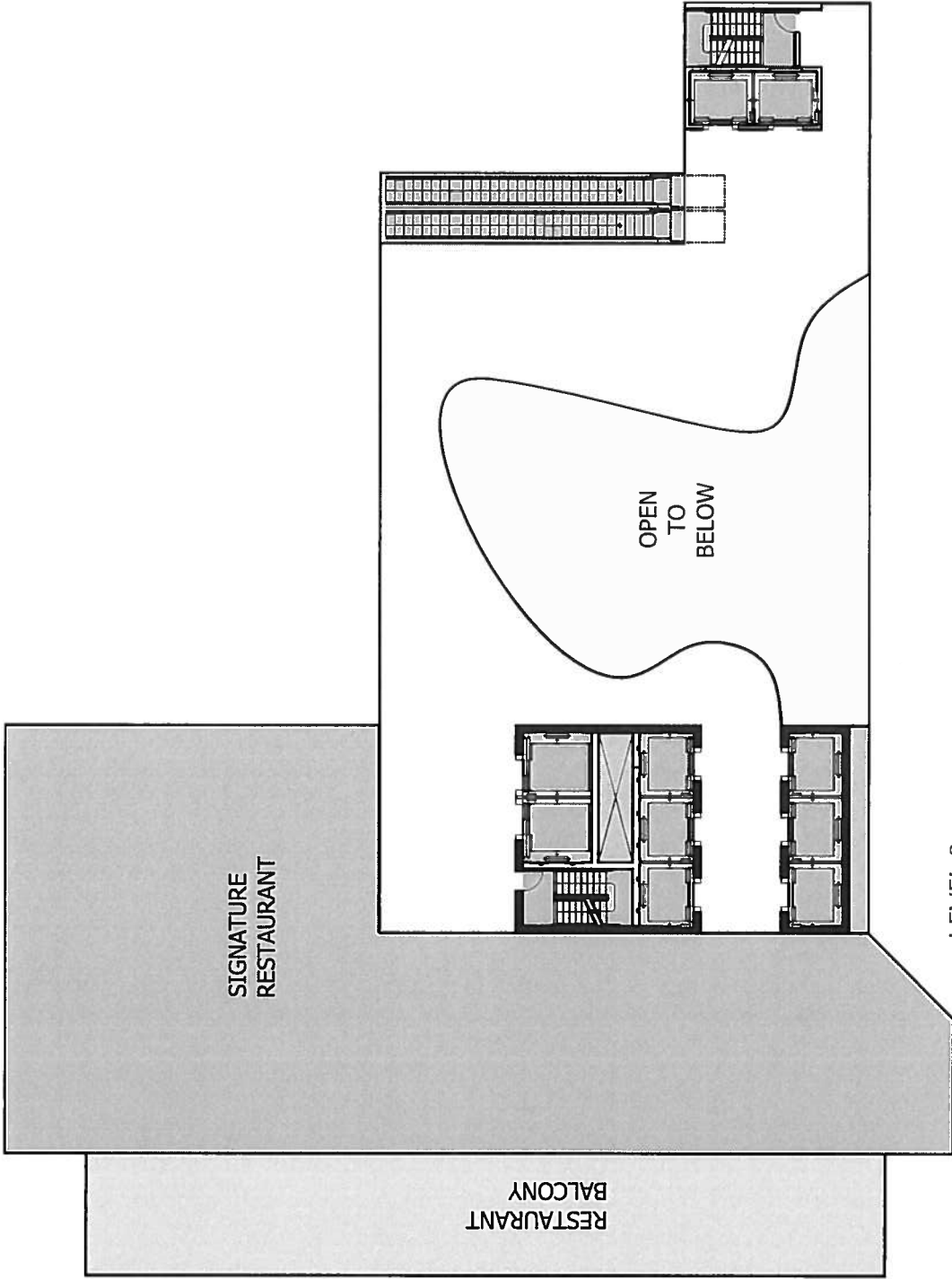

LEVEL 2
AREA: 17,094 sf

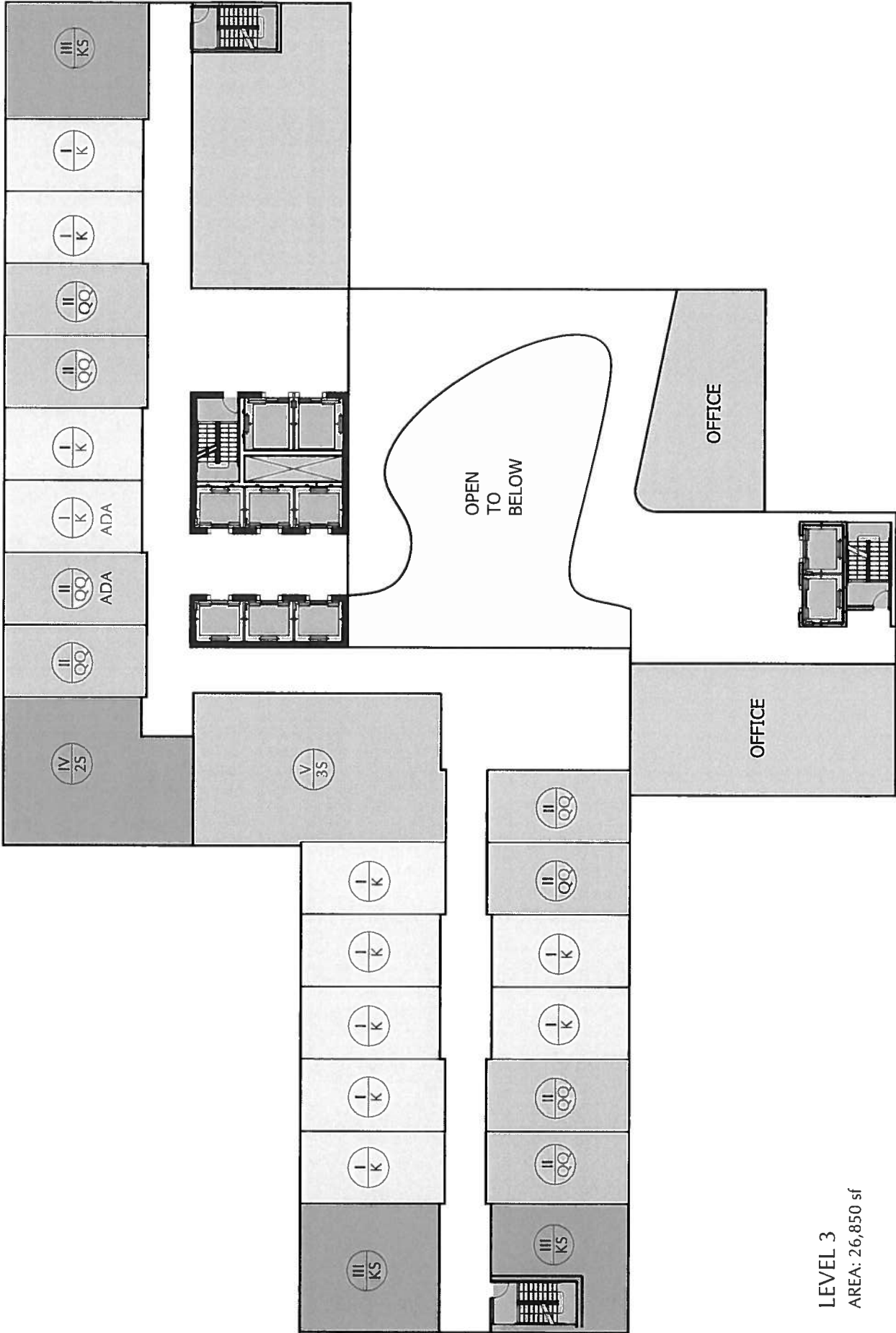

LEVEL 3
 AREA: 26,850 sf

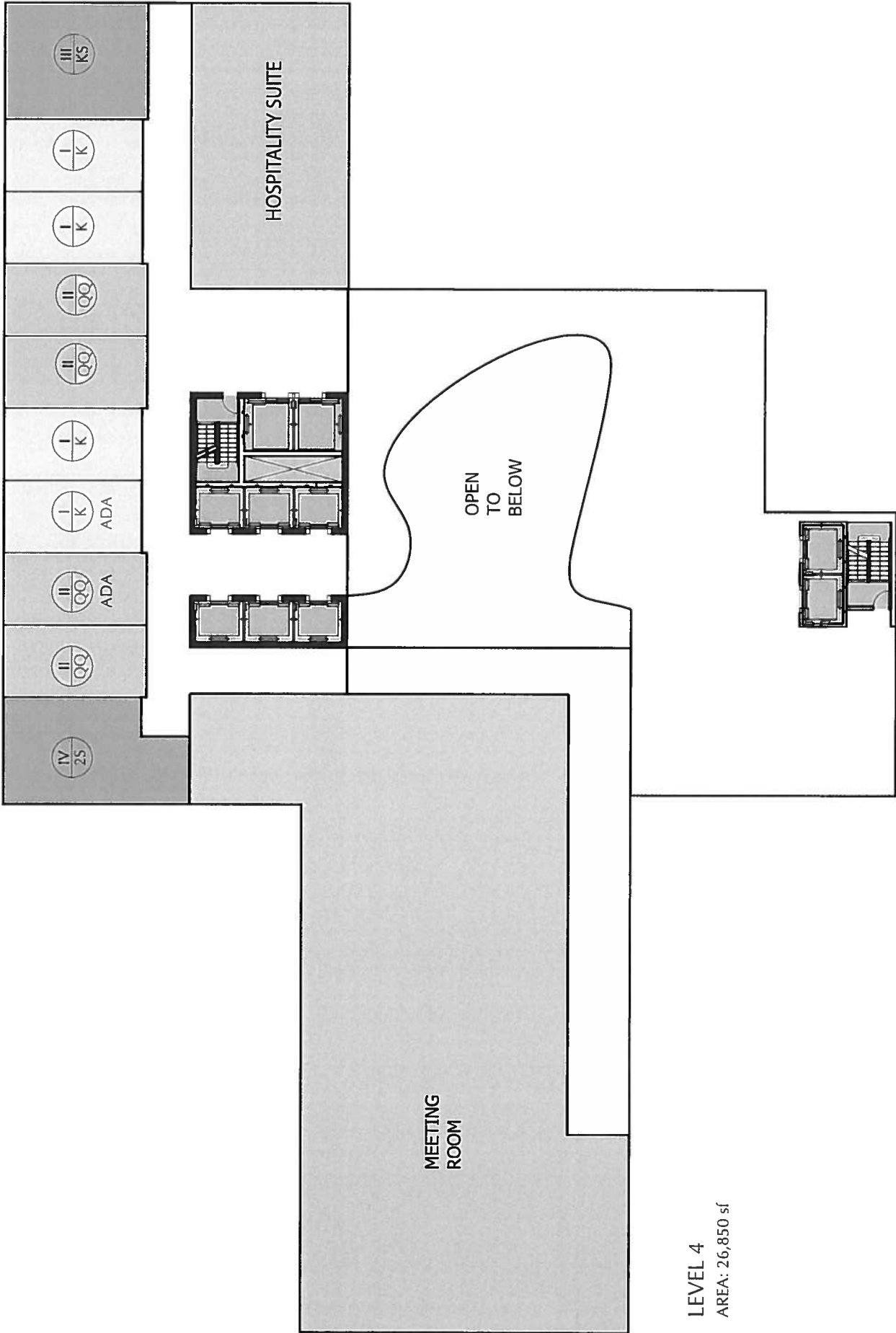

LEVEL 4
AREA: 26,850 sf

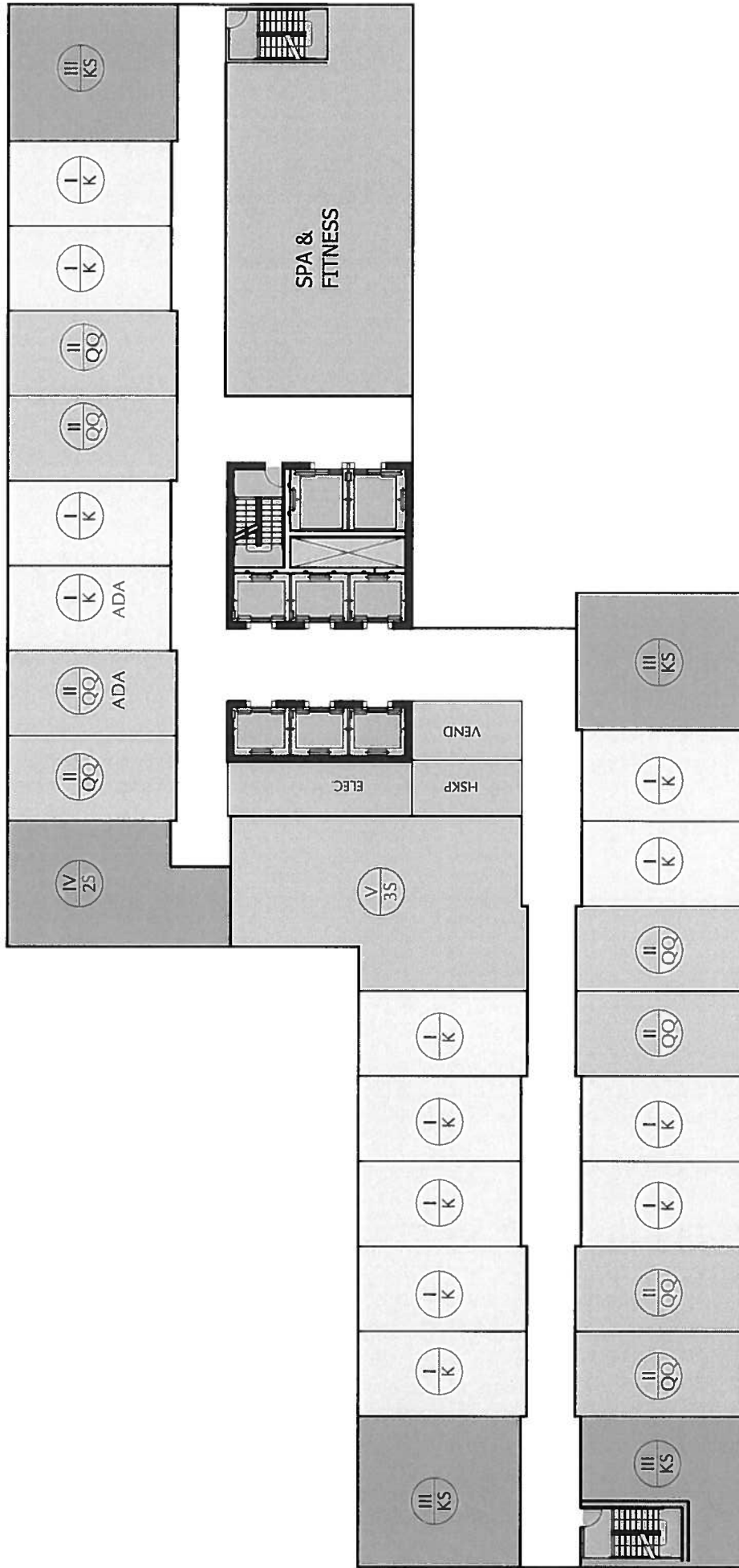

LEVEL 5
 AREA: 20,301 sf

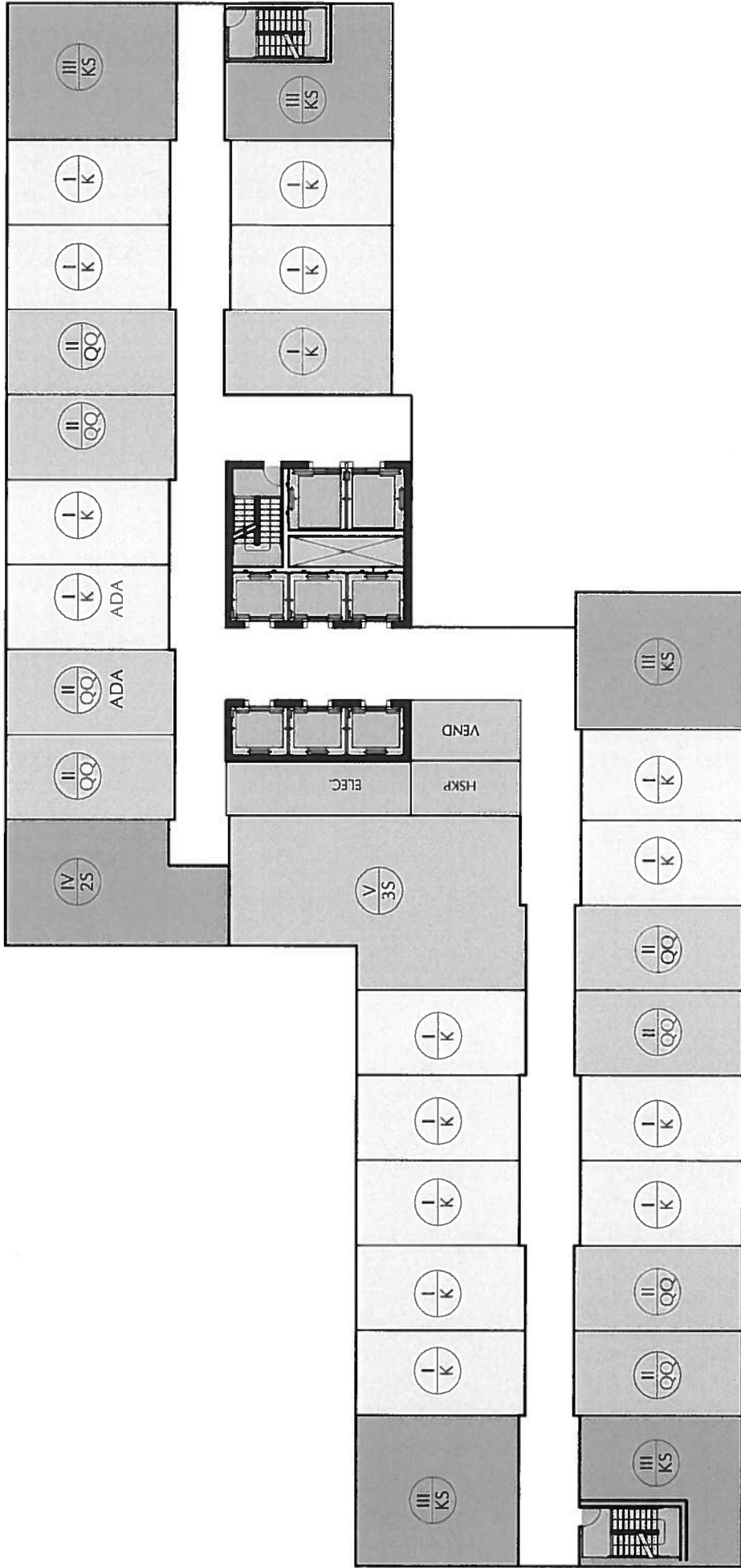

LEVEL 6 & 7
 AREA: 20,301 sf

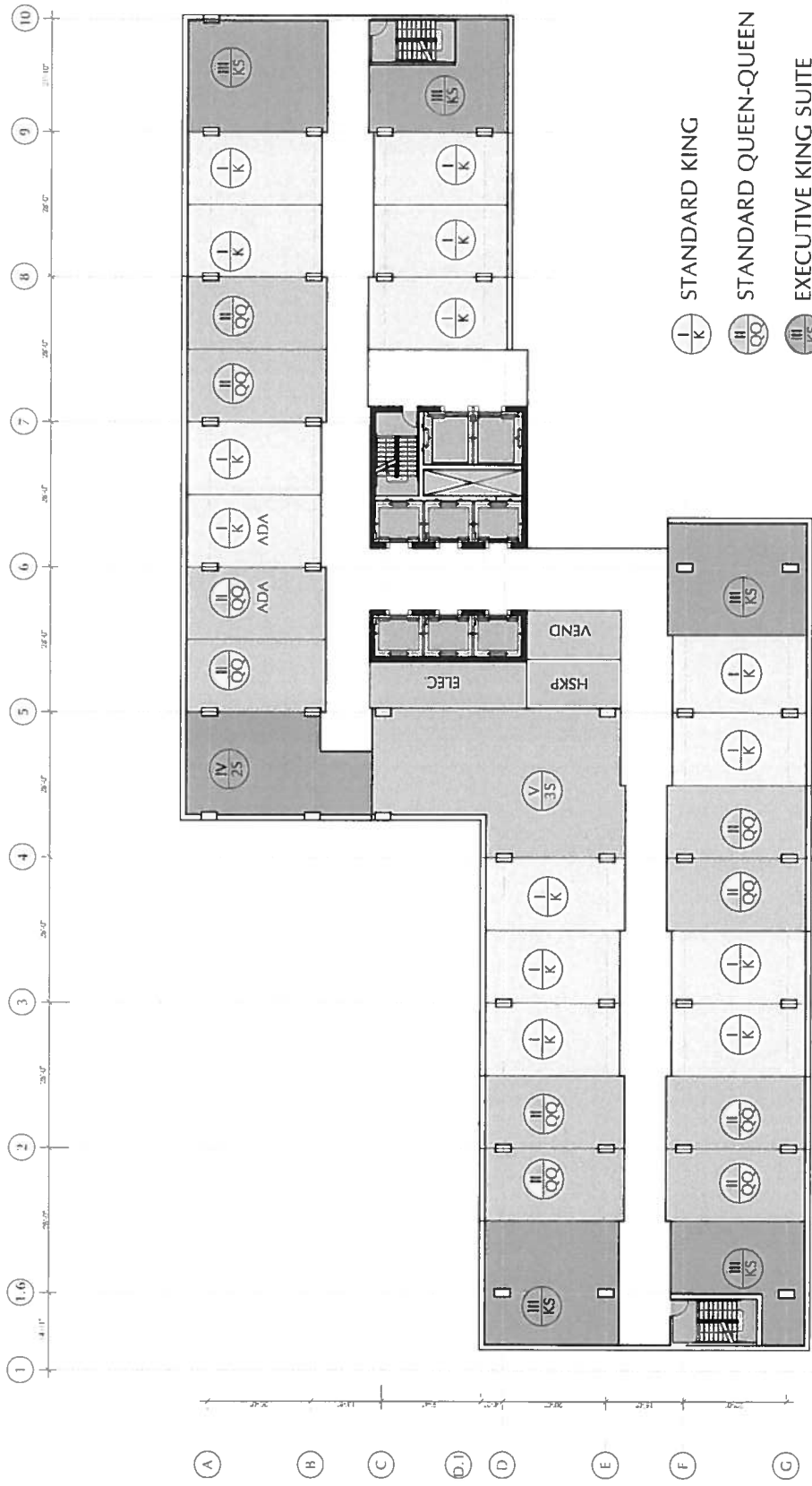

TYPICAL FLOOR LAYOUT
20,014 sf

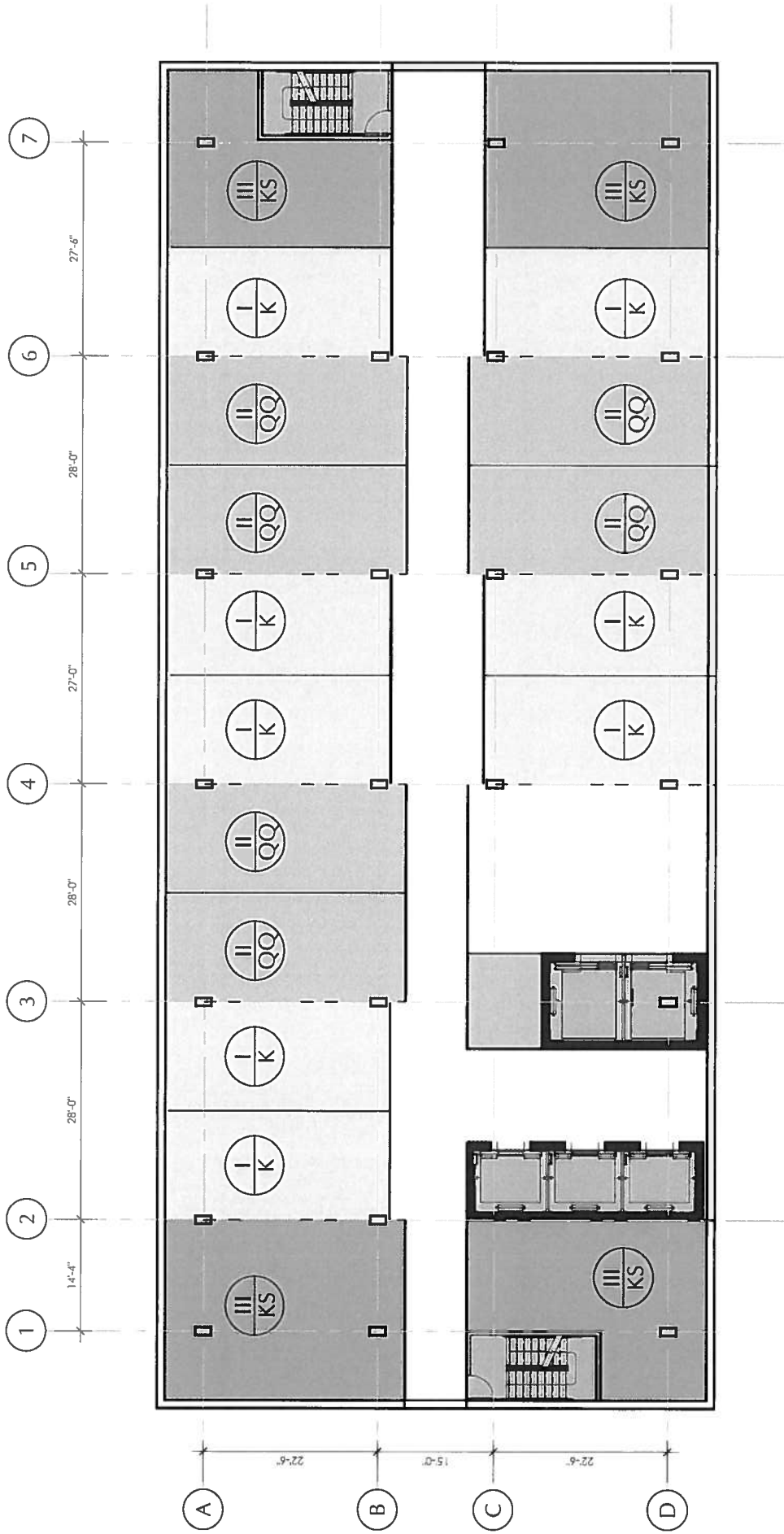

LEVEL 2-17

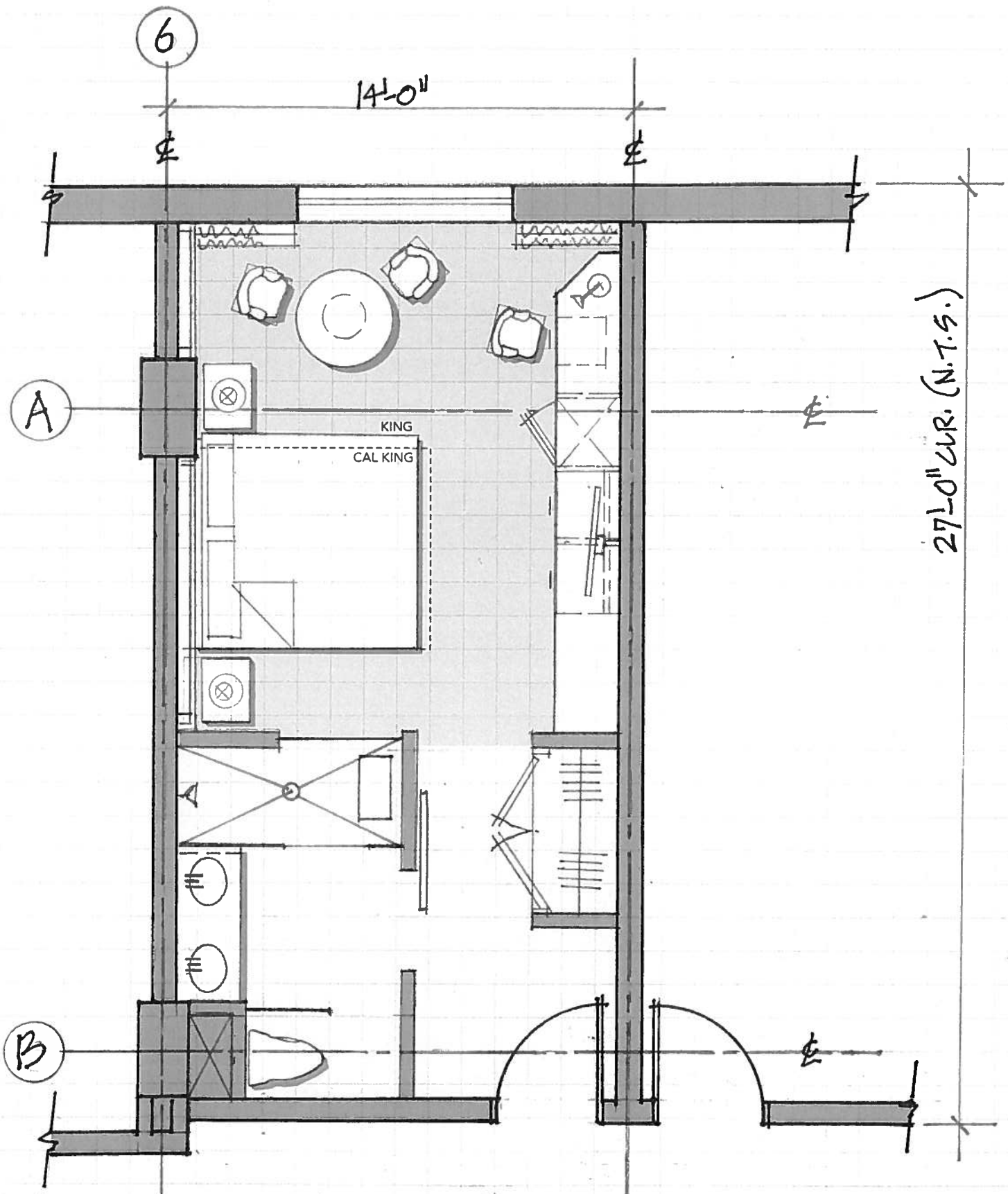

27'-0" CUR. (N.T.S.)

KING ROOM
 1/4" = 1'-0" 08/10/15

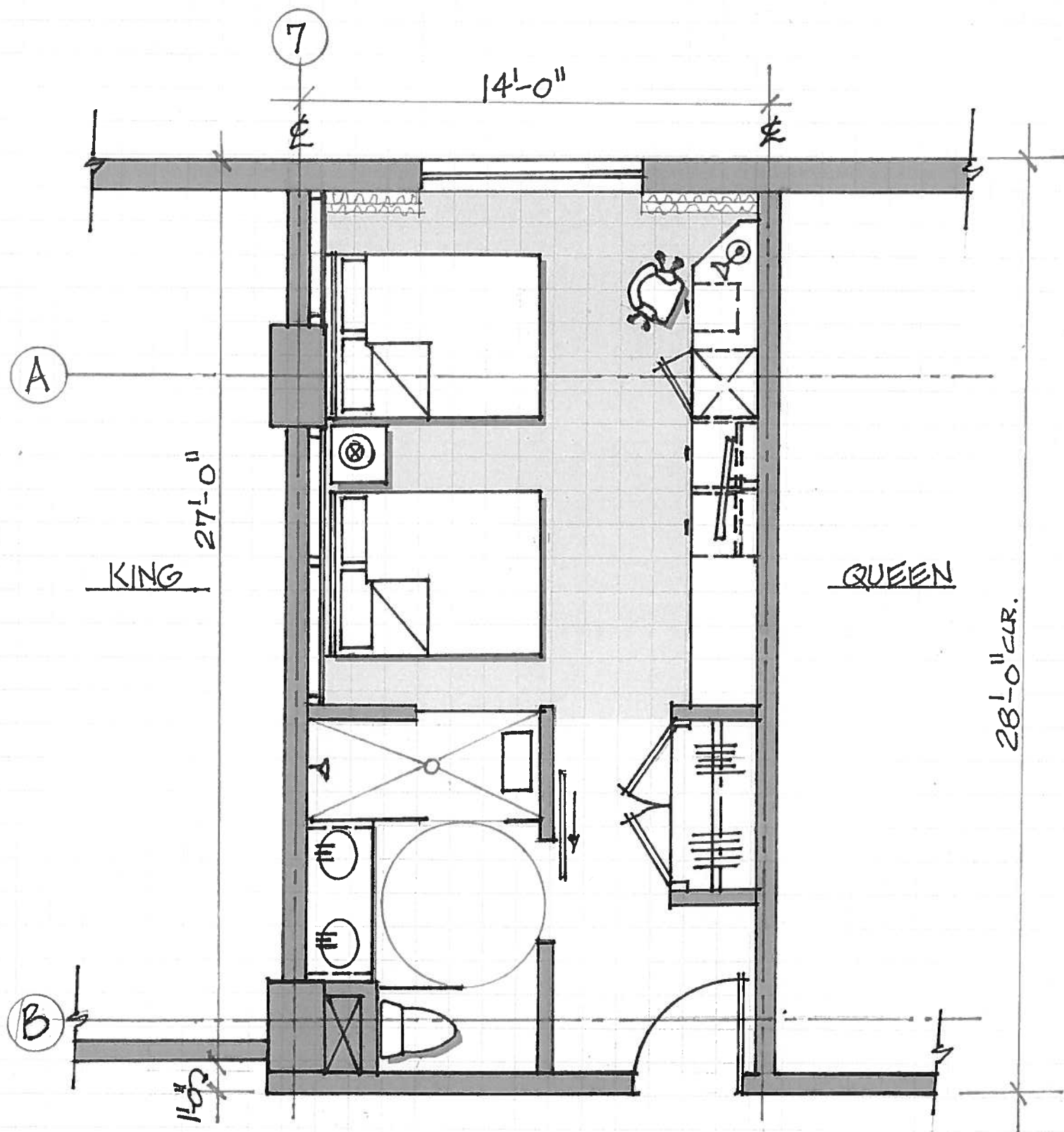

QUEEN/QUEEN ROOM

1/4" = 1'-0"

08/11/15

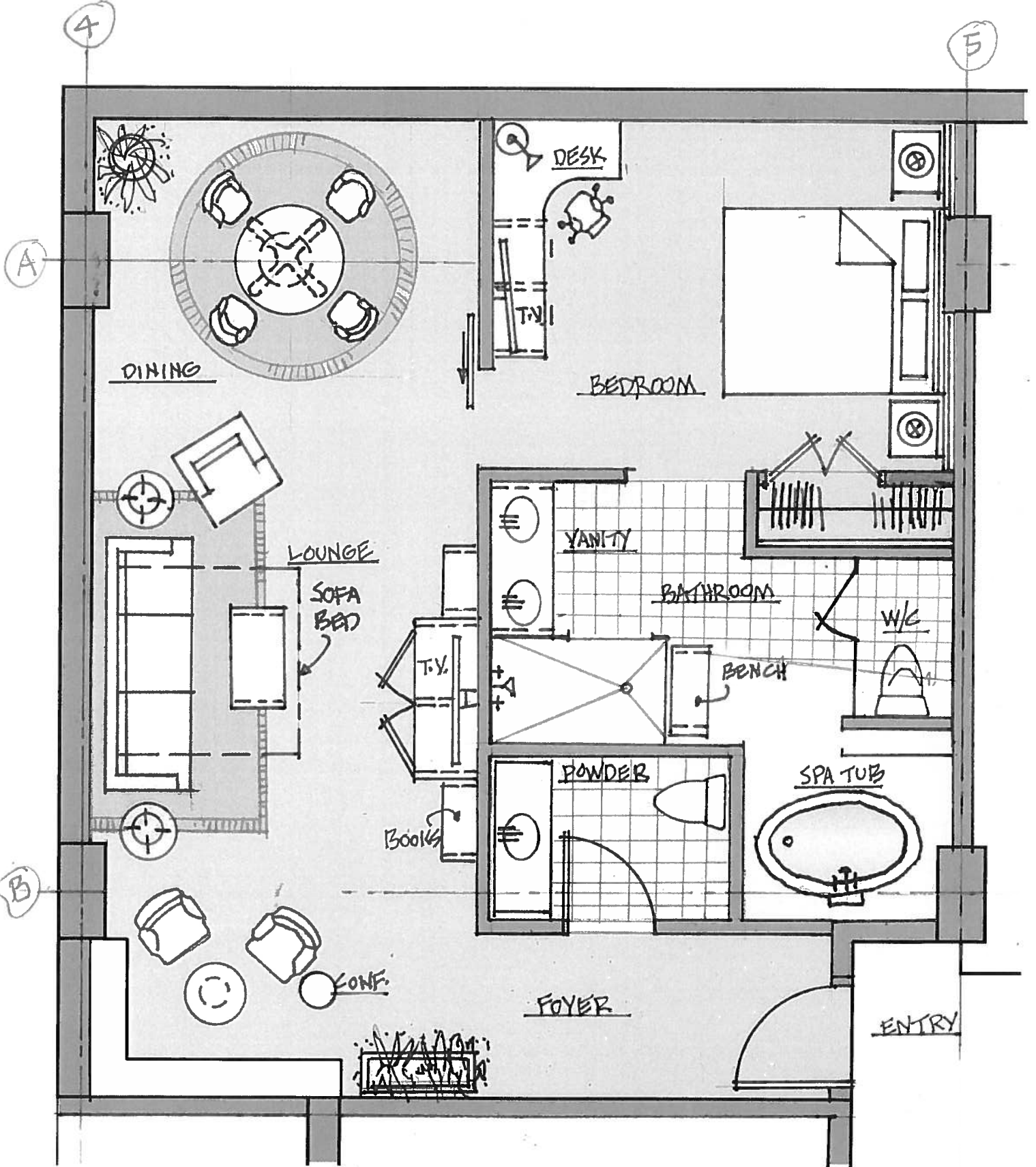

KING SUITE (2 BAY)
 1/4" = 1'-0" 08/13/15

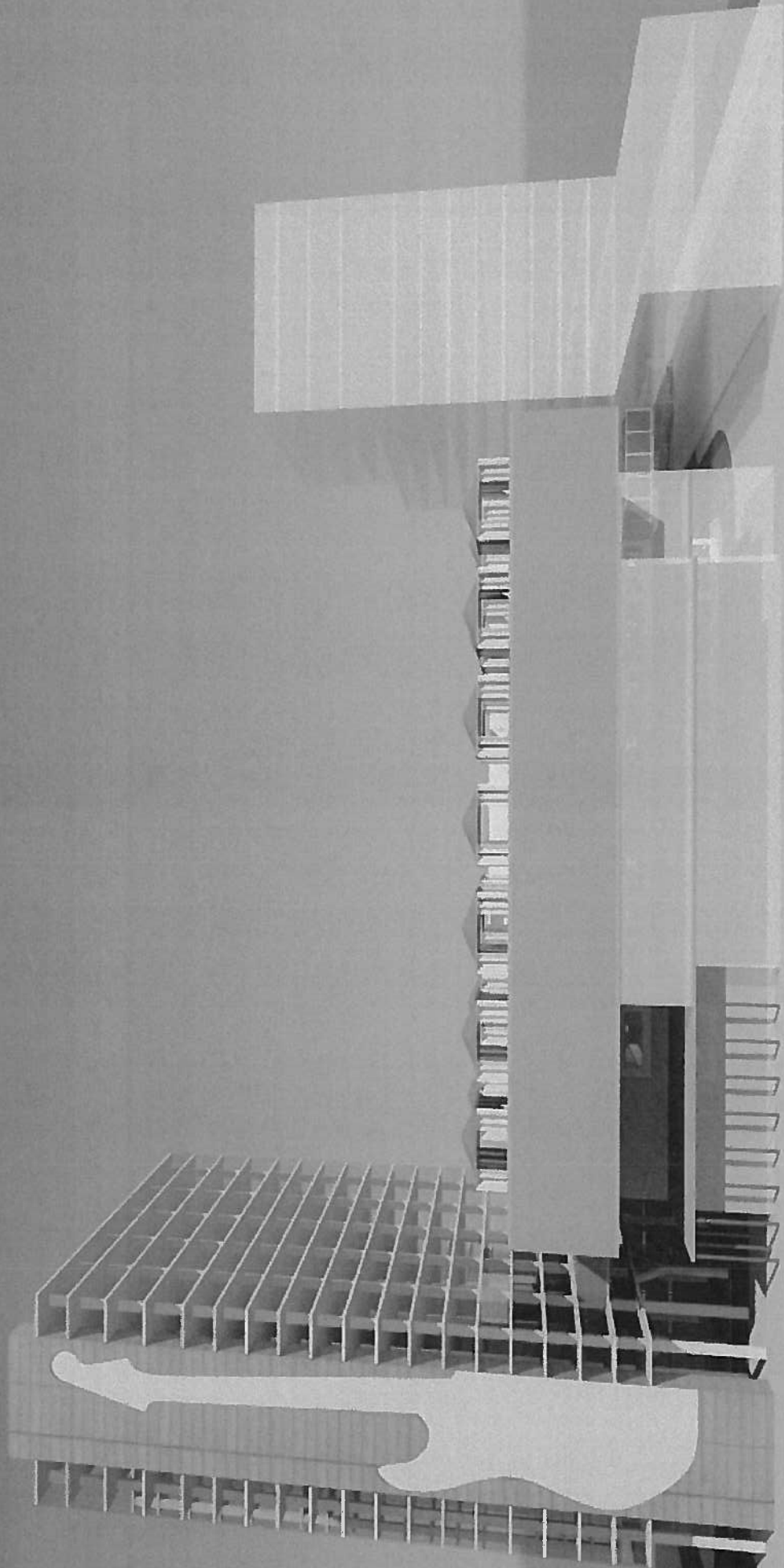

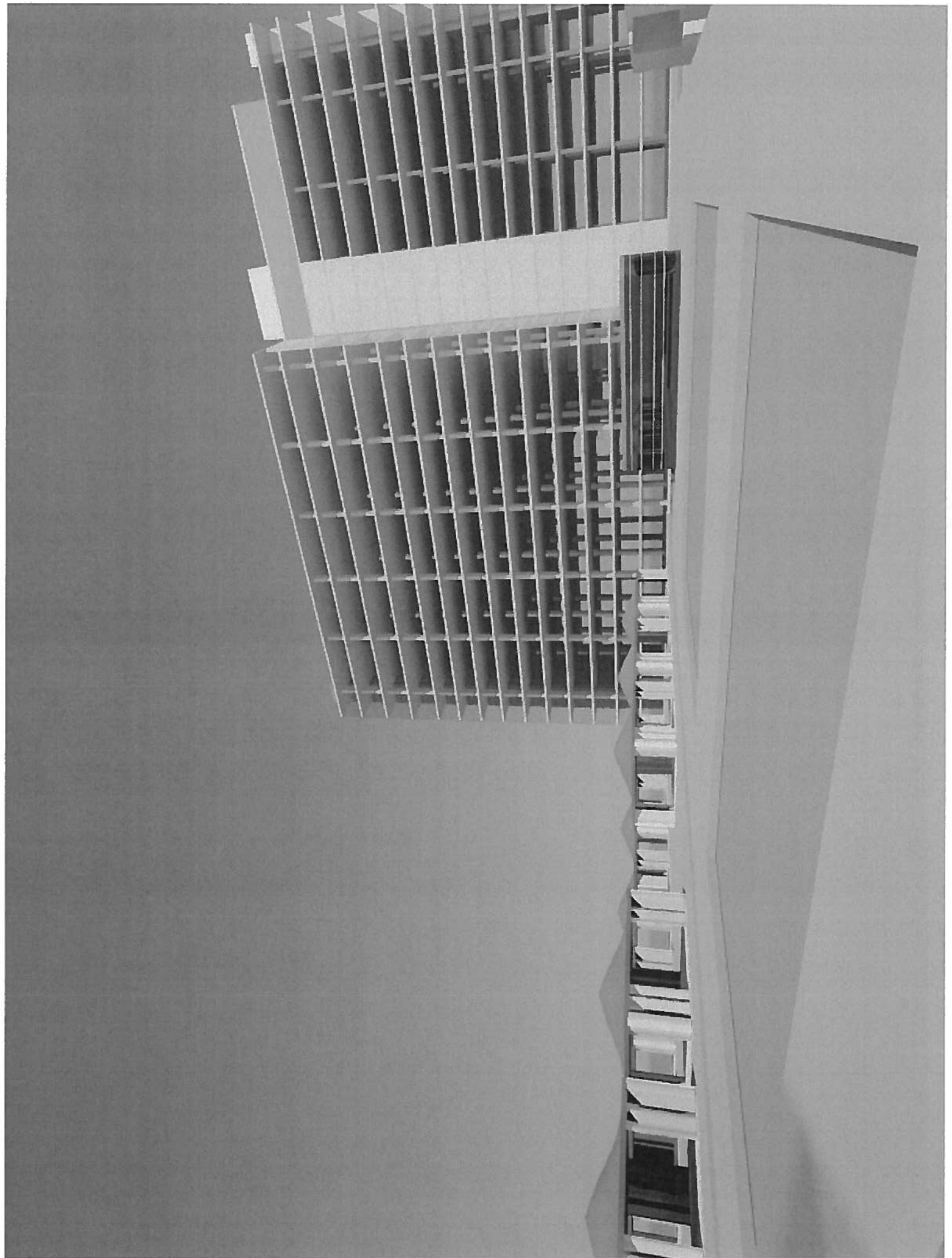

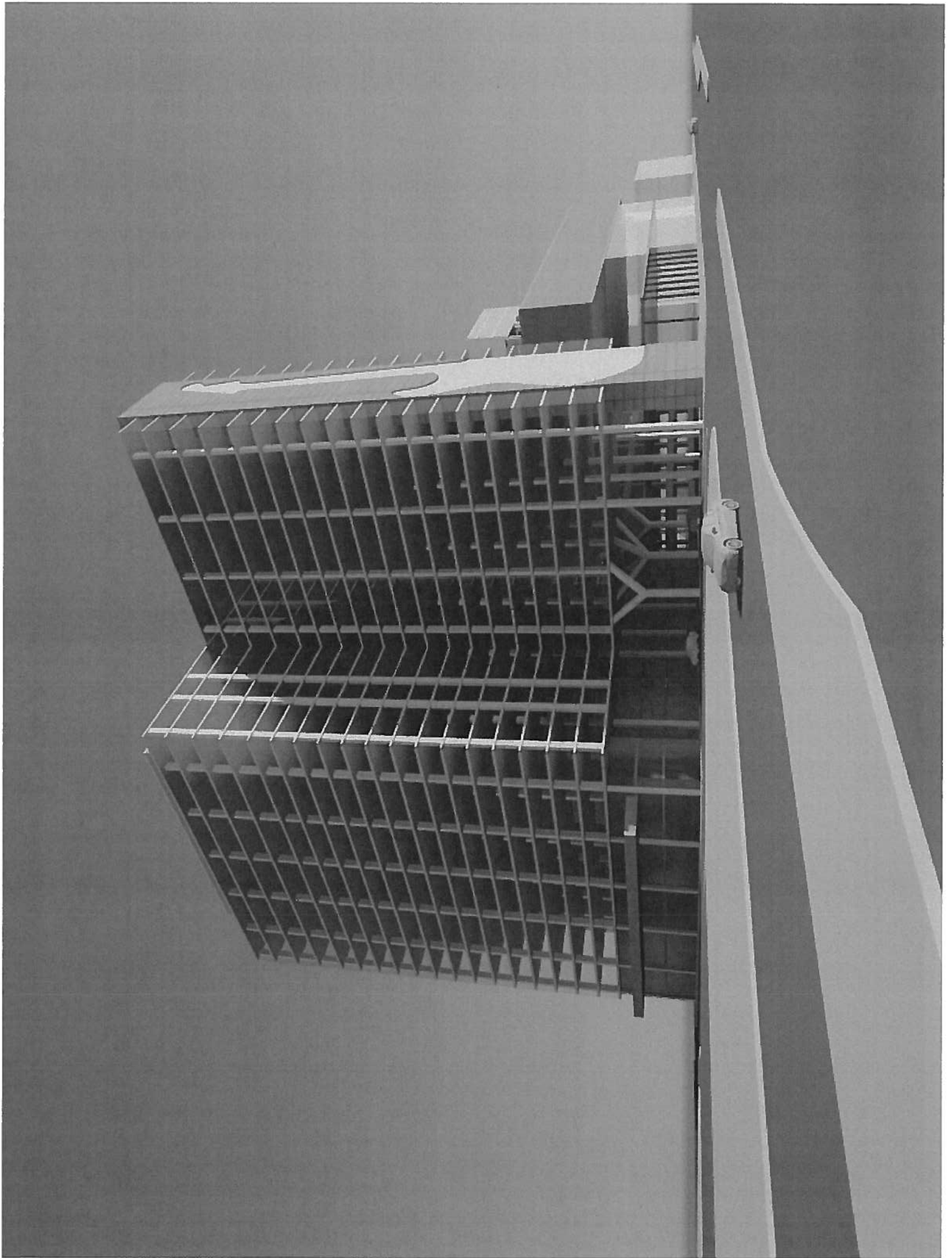

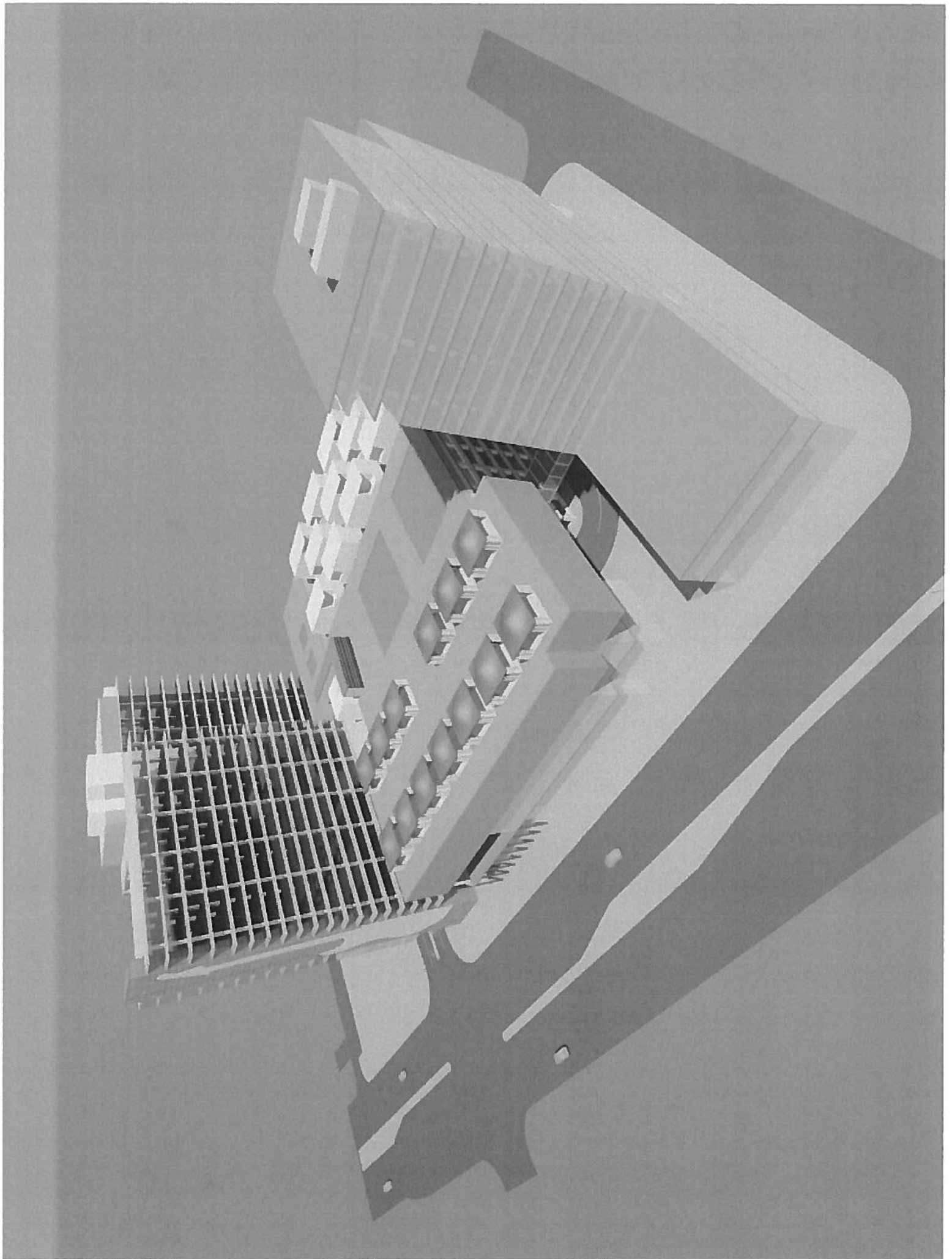



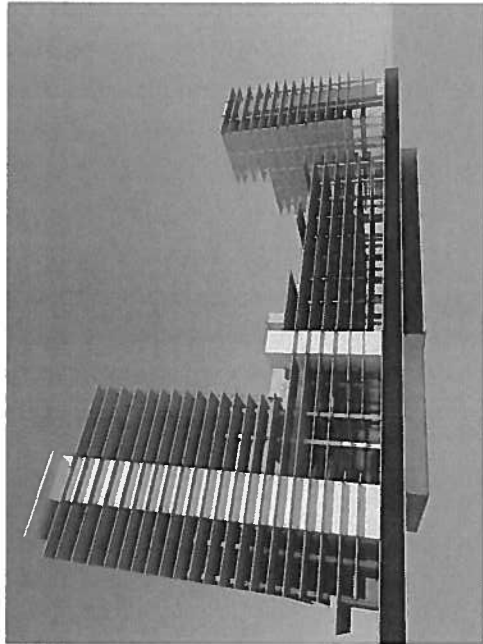

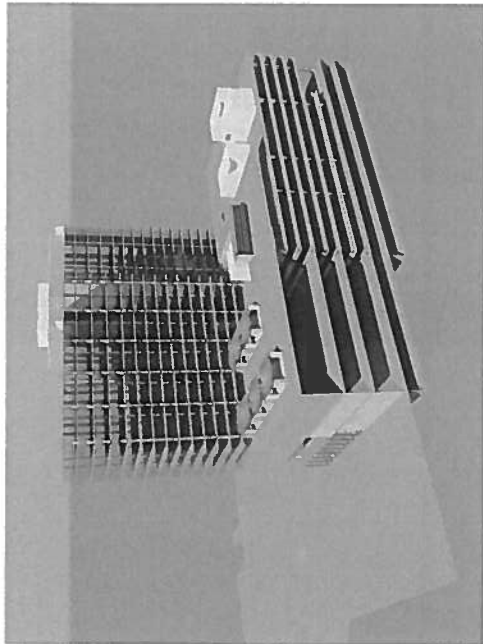

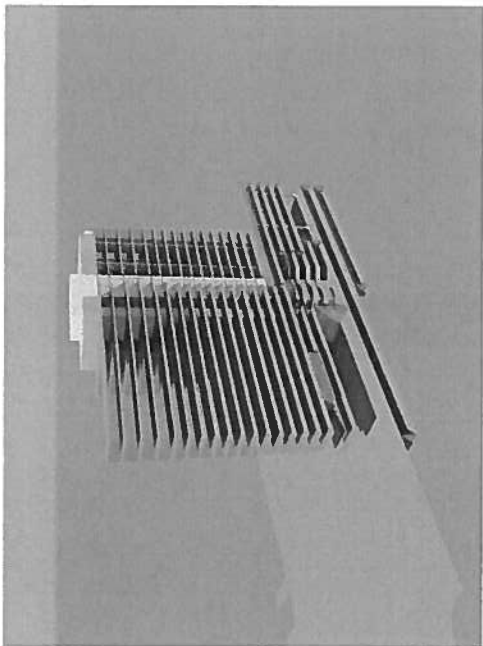

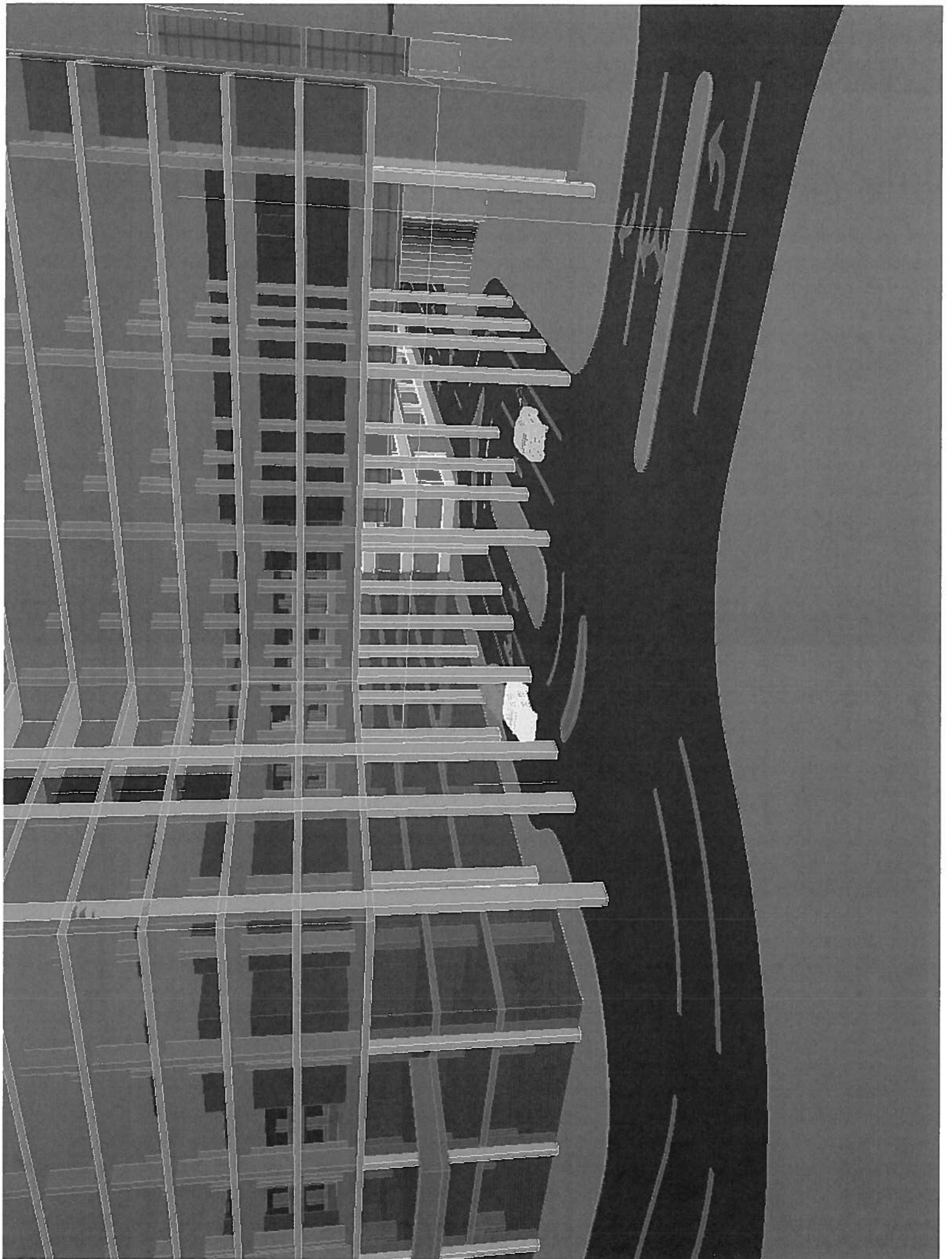

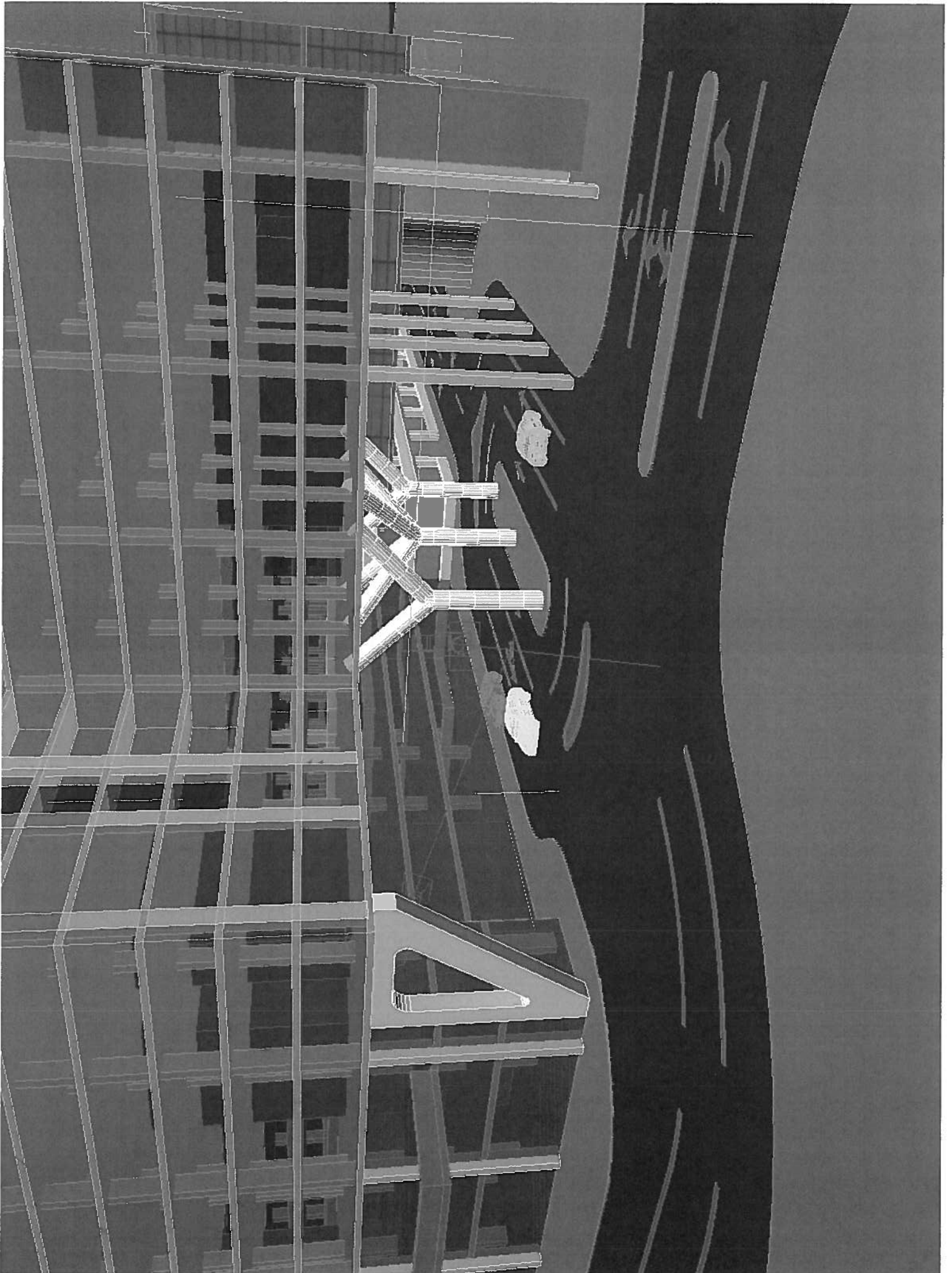

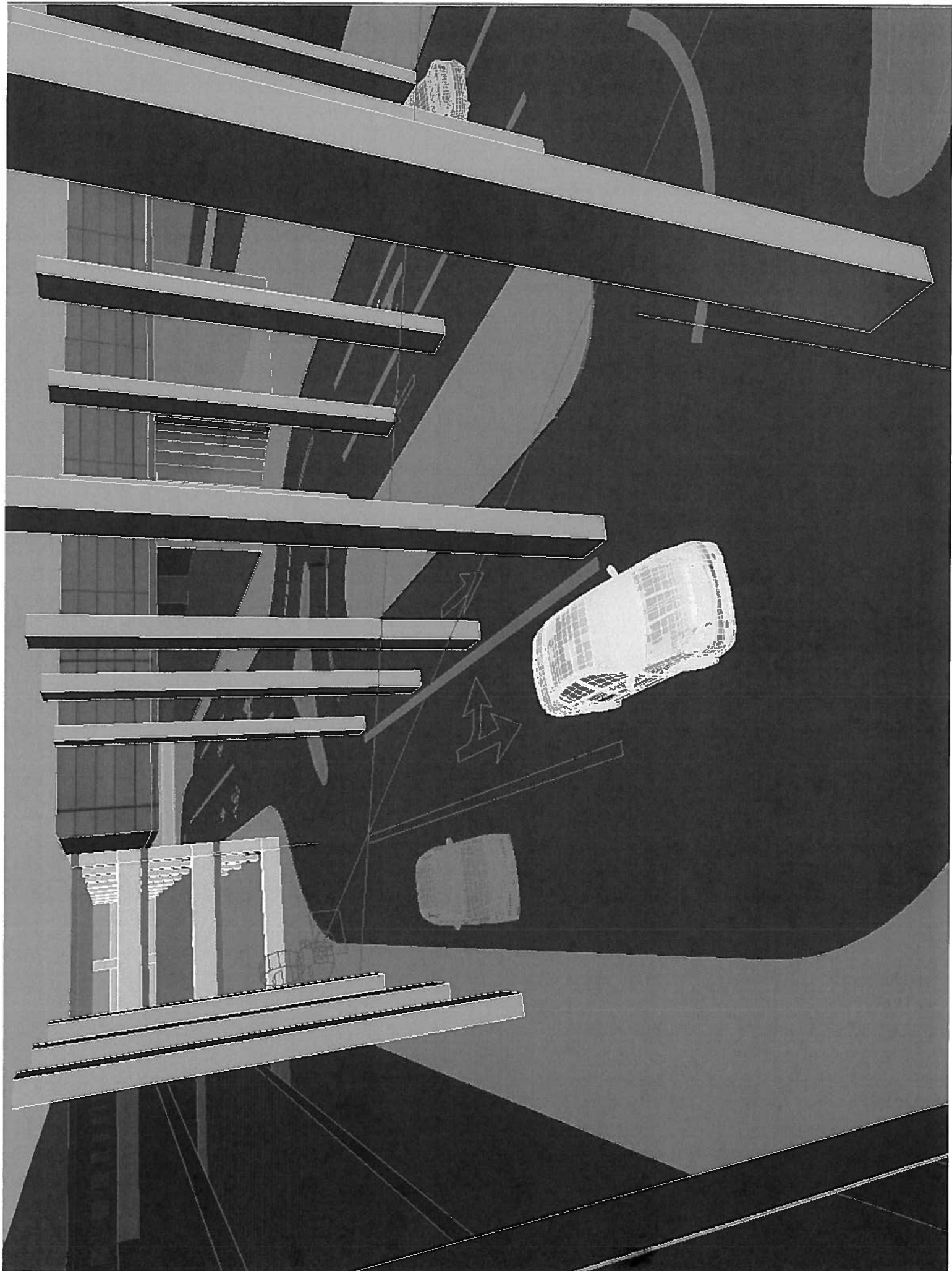

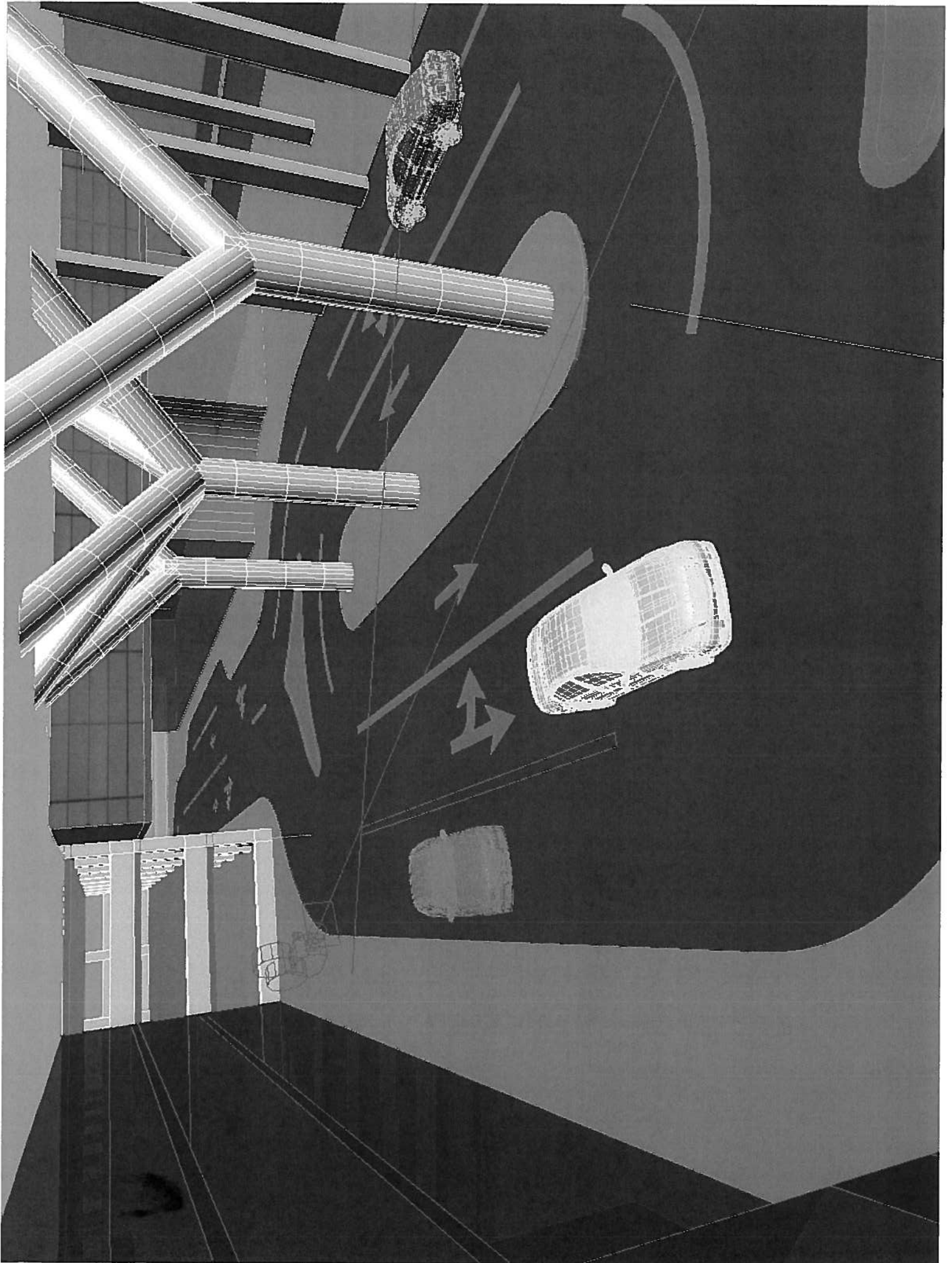

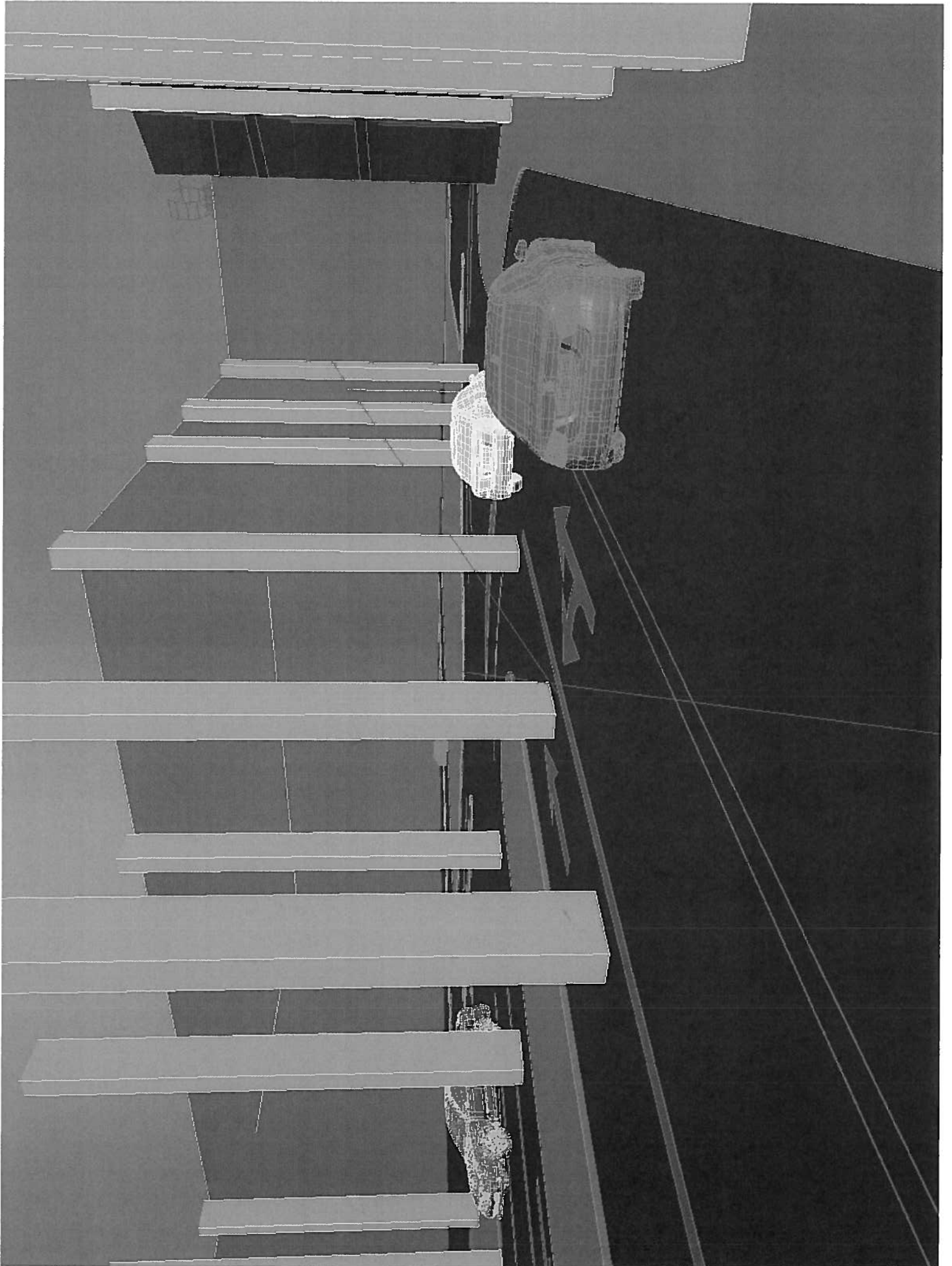

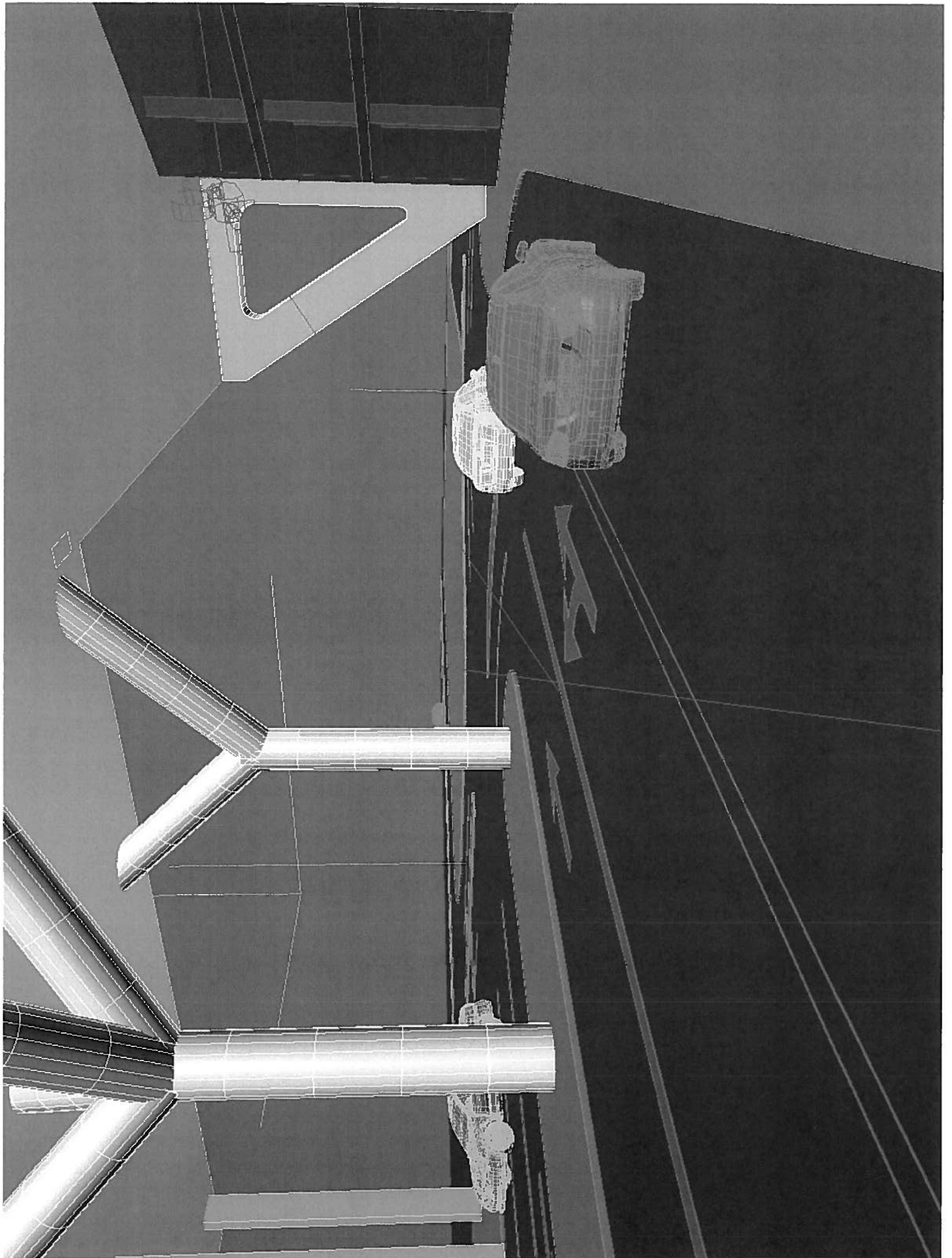

Subject: RE: Agreement for Reimbursement - Land & Design, Inc.
From: "Morgan, Jayna" <Jayna.Morgan@aecom.com>
Date: Tue, 18 Aug 2015 16:20:21 +0000
To: Matthew Reid <matt.reid@landanddesign.com>
CC: Alana Cheng <alanac@ci.garden-grove.ca.us>, Greg Blodgett <greg1@ci.garden-grove.ca.us>, Maria Parra <mariap@ci.garden-grove.ca.us>

We will need to know soon, but can also do a conference call with Maria and your team. Do you have the site plan??

Jayna Morgan
Environmental Planner/Senior Project Manager

AECOM
999 Town & Country Road, Orange, CA 92868
T 714.567.2417 F 714.567.2760
www.aecom.com

From: Matthew Reid [mailto:matt.reid@landanddesign.com]
Sent: Tuesday, August 18, 2015 8:47 AM
To: Morgan, Jayna
Cc: Alana Cheng; Greg Blodgett; Maria Parra
Subject: Re: Agreement for Reimbursement - Land & Design, Inc.

The wire is in process and our Arch is coming. We should meet regardless...

Sent from my iPhone
Matthew Reid
Land & Design, Inc.
3755 Avocado Blvd | #516 | LaMesa, CA 91941
619.567.2447 x101 office
858.735.1858 cell
619.489.3669 efax
Skype - [matthew.reid.ca](https://www.skype.com/people/matthew.reid.ca)
matt.reid@landanddesign.com

Check out our new website www.landanddesign.com

On Aug 18, 2015, at 8:37 AM, Morgan, Jayna <Jayna.Morgan@aecom.com> wrote:

Thank you!

Please let us know ASAP.

I spoke with Maria last night and she does not want to hold the meeting until the deposit is with the city.

Best regards,

Jayna Morgan

Project Manager

Sent from my iPhone

On Aug 18, 2015, at 8:32 AM, Alana Cheng <alanac@ci.garden-grove.ca.us> wrote:

Good Morning Matt,

I just received the original agreement this morning. Did you have a chance to verify with your partner that the wire has been sent? Please let me know when you can.

Thanks,
Alana

From: "Matthew Reid" <matt.reid@landanddesign.com>
To: "Alana Cheng" <alanac@ci.garden-grove.ca.us>
Cc: "Greg Blodgett" <greg1@ci.garden-grove.ca.us>, "Jayna Morgan" <jayna.morgan@aecom.com>, "Maria Parra" <mariap@ci.garden-grove.ca.us>
Sent: Monday, August 17, 2015 10:42:37 AM
Subject: Re: Agreement for Reimbursement - Land & Design, Inc.

Agreement was put in the mail, a day or two and should be in your hands.

I'll verify with our partner the wire has been sent....

Matthew Reid

Land & Design, Inc.
3755 Avocado Blvd | #516 | LaMesa, CA 91942
858.735.1858 cell
Skype - [matthew.reid.ca](https://www.skype.com/user/matthew.reid.ca)
matt.reid@landanddesign.com

Check out our new website www.landanddesign.com

On Aug 17, 2015, at 10:40 AM, Alana Cheng <alanac@ci.garden-grove.ca.us> wrote:

Hi Matt,

Please let me know if you wired the deposit on Friday so I can ask our Finance Department to verify. AECOM is coming tomorrow morning to meet with Maria. Also, I still have not received your original executed agreement.

Thank you,

Alana

From: "Alana Cheng" <alanac@ci.garden-grove.ca.us>
To: "Matthew Reid" <matt.reid@landanddesign.com>
Cc: "Greg Blodgett" <greg1@ci.garden-grove.ca.us>, "Jayna Morgan" <jayna.morgan@aecom.com>, "Karl Hill" <karlh@ci.garden-grove.ca.us>, "Maria Parra" <mariap@ci.garden-grove.ca.us>, "Susan Emery" <susan1@ci.garden-grove.ca.us>
Sent: Thursday, August 13, 2015 5:05:02 PM
Subject: Re: Agreement for Reimbursement - Land & Design, Inc.

Hi Matt,

Please find wiring instructions below:

Union Bank
ABA#: [REDACTED]
Credit to Account #: [REDACTED]
Account Name: City of Garden Grove - General Account
Beneficiary / Payee: City of Garden Grove
OBI: **Please see note below.**

** Please add the description for the deposit : **Site "C" CONSULTANT REIMBURSEMENT** so we can identify the money when it comes in.

Thank you,

Alana

From: "Matthew Reid" <matt.reid@landanddesign.com>
To: "Alana Cheng" <alanac@ci.garden-grove.ca.us>
Cc: "Greg Blodgett" <greg1@ci.garden-grove.ca.us>, "Jayna Morgan" <jayna.morgan@aecom.com>, "Karl Hill" <karlh@ci.garden-grove.ca.us>, "Maria Parra" <mariap@ci.garden-grove.ca.us>
Sent: Wednesday, August 12, 2015 11:14:11 AM
Subject: Re: Agreement for Reimbursement - Land & Design, Inc.

Attached signed agreement. Original is being sent via mail.
Can you forward wire instructions for deposit?

Matthew Reid

Land & Design, Inc.

3755 Avocado Blvd | #516 | LaMesa, CA 91942

858.735.1858 **cell**

Skype - [matthew.reid.ca](https://www.skype.com/people/matthew.reid.ca)

matt.reid@landanddesign.com

Check out our new website www.landanddesign.com

On Aug 4, 2015, at 11:18 AM, Alana Cheng
<alanac@ci.garden-grove.ca.us> wrote:

Hi all,

Please have this agreement executed and
mailed back to the City.

Let me know if you have questions.

Thanks,

Alana

<Land & Design, Inc.CEQA REVIEW

REIMBURSEMENT AGREEMENT w. AECOM

7.28.15.doc>

Subject: Re: Agreement for Reimbursement - Land & Design, Inc.
From: Alana Cheng <alanac@ci.garden-grove.ca.us>
Date: Tue, 18 Aug 2015 09:35:40 -0700 (PDT)
To: "Morgan, Jayna" <Jayna.Morgan@aecom.com>
CC: Matthew Reid <matt.reid@landanddesign.com>, Greg Blodgett <greg1@ci.garden-grove.ca.us>, Maria Parra <mariap@ci.garden-grove.ca.us>

Our finance dept has not received the deposit yet so Maria said the meeting will be postponed with AECOM.

Thx!

Alana

On Aug 18, 2015, at 8:38 AM, Morgan, Jayna <Jayna.Morgan@aecom.com> wrote:

Thank you!

Please let us know ASAP.

I spoke with Maria last night and she does not want to hold the meeting until the deposit is with the city.

Best regards,

Jayna Morgan

Project Manager

Sent from my iPhone

On Aug 18, 2015, at 8:32 AM, Alana Cheng <alanac@ci.garden-grove.ca.us> wrote:

Good Morning Matt,

I just received the original agreement this morning. Did you have a chance to verify with your partner that the wire has been sent? Please let me know when you can.

Thanks,

Alana

From: "Matthew Reid" <matt.reid@landanddesign.com>
To: "Alana Cheng" <alanac@ci.garden-grove.ca.us>
Cc: "Greg Blodgett" <greg1@ci.garden-grove.ca.us>, "Jayna Morgan" <jayna.morgan@aecom.com>, "Maria Parra" <mariap@ci.garden-grove.ca.us>
Sent: Monday, August 17, 2015 10:42:37 AM
Subject: Re: Agreement for Reimbursement - Land & Design, Inc.

Agreement was put in the mail, a day or two and should be in your hands.
I'll verify with our partner the wire has been sent....

Matthew Reid

Land & Design, Inc.

3755 Avocado Blvd | #516 | LaMesa, CA 91942

858.735.1858 cell

Skype - [matthew.reid.ca](https://www.skype.com/user/matthew.reid.ca)

matt.reid@landanddesign.com

Check out our new website www.landanddesign.com

On Aug 17, 2015, at 10:40 AM, Alana Cheng <alanac@ci.garden-grove.ca.us> wrote:

Hi Matt,

Please let me know if you wired the deposit on Friday so I can ask our Finance Department to verify. AECOM is coming tomorrow morning to meet with Maria. Also, I still have not received your original executed agreement.

Thank you,

Alana

From: "Alana Cheng" <alanac@ci.garden-grove.ca.us>

To: "Matthew Reid" <matt.reid@landanddesign.com>

Cc: "Greg Blodgett" <greg1@ci.garden-grove.ca.us>, "Jayna Morgan" <jayna.morgan@aecom.com>, "Karl Hill" <karlh@ci.garden-grove.ca.us>, "Maria Parra" <mariap@ci.garden-grove.ca.us>, "Susan Emery" <susan1@ci.garden-grove.ca.us>

Sent: Thursday, August 13, 2015 5:05:02 PM

Subject: Re: Agreement for Reimbursement - Land & Design, Inc.

Hi Matt,

Please find wiring instructions below:

Union Bank

ABA#: [REDACTED]

Credit to Account #: [REDACTED]

Account Name: City of Garden Grove - General Account

Beneficiary / Payee: City of Garden Grove

OBI: ****Please see note below.****

**** Please add the description for the deposit : Site "C" CONSULTANT REIMBURSEMENT so we can identify the money when it comes in.**

Thank you,

Alana

From: "Matthew Reid" <matt.reid@landanddesign.com>
To: "Alana Cheng" <alanac@ci.garden-grove.ca.us>
Cc: "Greg Blodgett" <greg1@ci.garden-grove.ca.us>, "Jayna Morgan" <jayna.morgan@aecom.com>, "Karl Hill" <karlh@ci.garden-grove.ca.us>, "Maria Parra" <mariap@ci.garden-grove.ca.us>
Sent: Wednesday, August 12, 2015 11:14:11 AM
Subject: Re: Agreement for Reimbursement - Land & Design, Inc.

Attached signed agreement. Original is being sent via mail.
Can you forward wire instructions for deposit?

Matthew Reid

Land & Design, Inc.
3755 Avocado Blvd | #516 | LaMesa, CA 91942
858.735.1858 cell
Skype - [matthew.reid.ca](https://www.skype.com/user/matthew.reid.ca)
matt.reid@landanddesign.com

Check out our new website www.landanddesign.com

On Aug 4, 2015, at 11:18 AM, Alana Cheng <alanac@ci.garden-grove.ca.us> wrote:

Hi all,

Please have this agreement executed and mailed back to the City.

Let me know if you have questions.

Thanks,

Alana

<Land & Design, Inc.CEQA REVIEW REIMBURSEMENT
AGREEMENT w. AECOM 7.28.15.doc>

Subject: Re: Agreement for Reimbursement - Land & Design, Inc.
From: Maria Parra <mariap@ci.garden-grove.ca.us>
Date: Tue, 18 Aug 2015 10:15:44 -0700 (PDT)
To: Matthew Reid <matt.reid@landanddesign.com>
CC: Alana Cheng <alanac@ci.garden-grove.ca.us>, Greg Blodgett <greg1@ci.garden-grove.ca.us>, Jayna Morgan <Jayna.Morgan@aecom.com>

Matt:

City staff is available to meet with you at 10:30 a.m. today to discuss the project; however, any meeting with AECOM to discuss the environmental will have to wait until the City has received the deposit. Once we received confirmation from our Finance Dept., we can proceed with a meeting with AECOM. However, Jayna from AECOM has indicated that at the end of our meeting, if we have any questions, that she will be available.

Best regards,

Maria Parra

Urban Planner
City of Garden Grove | Planning Services Division
11222 Acacia Parkway, Garden Grove, CA 92840
(714) 741-5312 | (714) 741-5578 fax
mariap@ci.garden-grove.ca.us | www.ci.garden-grove.ca.us

Community Development Department of the City of Garden Grove
"Providing Quality Services Through Creativity and Collaboration"

City Hall Hours:
Monday-Thursday: 7:30 a.m. to 5:30 p.m.
First Friday of the Month: 7:30 a.m. to 5:00 p.m.

Direct Website Links:
[Planning Division](#)
[Municipal Code, Title 9, Land Use](#)
[Zoning Map](#)

From: "Matthew Reid" <matt.reid@landanddesign.com>
To: "Jayna Morgan" <Jayna.Morgan@aecom.com>
Cc: "Alana Cheng" <alanac@ci.garden-grove.ca.us>, "Greg Blodgett" <greg1@ci.garden-grove.ca.us>, "Maria Parra" <mariap@ci.garden-grove.ca.us>
Sent: Tuesday, August 18, 2015 8:41:49 AM
Subject: Re: Agreement for Reimbursement - Land & Design, Inc.

Greg?

Sent from my iPhone

Matthew Reid
Land & Design, Inc.
3755 Avocado Blvd | #516 | LaMesa, CA 91941
619.567.2447 x101 office
858.735.1858 cell
619.489.3669 efax
Skype - matthew.reid.ca
matt.reid@landanddesign.com

Check out our new website www.landanddesign.com

On Aug 18, 2015, at 8:37 AM, Morgan, Jayna <Jayna.Morgan@aecom.com> wrote:

Thank you!

Please let us know ASAP.

I spoke with Maria last night and she does not want to hold the meeting until the deposit is with the city.

Best regards,

Jayna Morgan

Project Manager

Sent from my iPhone

On Aug 18, 2015, at 8:32 AM, Alana Cheng <alanac@ci.garden-grove.ca.us> wrote:

Good Morning Matt,

I just received the original agreement this morning. Did you have a chance to verify with your partner that the wire has been sent? Please let me know when you can.

Thanks,

Alana

From: "Matthew Reid" <matt.reid@landanddesign.com>

To: "Alana Cheng" <alanac@ci.garden-grove.ca.us>

Cc: "Greg Blodgett" <greg1@ci.garden-grove.ca.us>, "Jayna Morgan" <jayna.morgan@aecom.com>, "Maria Parra" <mariap@ci.garden-grove.ca.us>

Sent: Monday, August 17, 2015 10:42:37 AM

Subject: Re: Agreement for Reimbursement - Land & Design, Inc.

Agreement was put in the mail, a day or two and should be in your hands.

I'll verify with our partner the wire has been sent...

Matthew Reid

Land & Design, Inc.

3755 Avocado Blvd | #516 | LaMesa, CA 91942

858.735.1858 cell

Skype - [matthew.reid.ca](https://www.skype.com/user/matthew.reid.ca)

matt.reid@landanddesign.com

Check out our new website www.landanddesign.com

On Aug 17, 2015, at 10:40 AM, Alana Cheng
<alanac@ci.garden-grove.ca.us> wrote:

Hi Matt,

Please let me know if you wired the deposit on Friday so I can ask our Finance Department to verify. AECOM is coming tomorrow morning to meet with Maria. Also, I still have not received your original executed agreement.

Thank you,

Alana

From: "Alana Cheng" <alanac@ci.garden-grove.ca.us>
To: "Matthew Reid" <matt.reid@landanddesign.com>
Cc: "Greg Blodgett" <greg1@ci.garden-grove.ca.us>, "Jayna Morgan" <jayna.morgan@aecom.com>, "Karl Hill" <karlh@ci.garden-grove.ca.us>, "Maria Parra" <mariap@ci.garden-grove.ca.us>, "Susan Emery" <susan1@ci.garden-grove.ca.us>
Sent: Thursday, August 13, 2015 5:05:02 PM
Subject: Re: Agreement for Reimbursement - Land & Design, Inc.

Hi Matt,

Please find wiring instructions below:

Union Bank

ABA#: [REDACTED]

Credit to Account #: [REDACTED]

Account Name: City of Garden Grove - General Account

Beneficiary / Payee: City of Garden Grove

OBI: **Please see note below.**

** Please add the description for the deposit : **Site "C" CONSULTANT REIMBURSEMENT** so we can identify the money when it comes in.

Thank you,

Alana

From: "Matthew Reid" <matt.reid@landanddesign.com>
To: "Alana Cheng" <alanac@ci.garden-grove.ca.us>
Cc: "Greg Blodgett" <greg1@ci.garden-grove.ca.us>, "Jayna Morgan" <jayna.morgan@aecom.com>, "Karl Hill" <karlh@ci.garden-grove.ca.us>, "Maria Parra" <mariap@ci.garden-grove.ca.us>
Sent: Wednesday, August 12, 2015 11:14:11 AM
Subject: Re: Agreement for Reimbursement - Land & Design, Inc.

Attached signed agreement. Original is being sent via mail.
Can you forward wire instructions for deposit?

Matthew Reid

Land & Design, Inc.

3755 Avocado Blvd | #516 | LaMesa, CA 91942

858.735.1858 cell

Skype - [matthew.reid.ca](https://www.skype.com/people/matthew.reid.ca)

matt.reid@landanddesign.com

Check out our new website www.landanddesign.com

On Aug 4, 2015, at 11:18 AM, Alana Cheng
<alanac@ci.garden-grove.ca.us> wrote:

Hi all,

Please have this agreement executed and
mailed back to the City.

Let me know if you have questions.

Thanks,
Alana
<Land & Design, Inc.CEQA REVIEW
REIMBURSEMENT AGREEMENT w. AECOM
7.28.15.doc>

Subject: Re: Agreement for Reimbursement - Land & Design, Inc.
From: Maria Parra <mariap@ci.garden-grove.ca.us>
Date: Tue, 18 Aug 2015 10:15:44 -0700 (PDT)
To: Matthew Reid <matt.reid@landanddesign.com>
CC: Alana Cheng <alanac@ci.garden-grove.ca.us>, Greg Blodgett <greg1@ci.garden-grove.ca.us>, Jayna Morgan <Jayna.Morgan@aecom.com>

Matt:

City staff is available to meet with you at 10:30 a.m. today to discuss the project; however, any meeting with AECOM to discuss the environmental will have to wait until the City has received the deposit. Once we received confirmation from our Finance Dept., we can proceed with a meeting with AECOM. However, Jayna from AECOM has indicated that at the end of our meeting, if we have any questions, that she will be available.

Best regards,

Maria Parra

Urban Planner
City of Garden Grove | Planning Services Division
11222 Acacia Parkway, Garden Grove, CA 92840
(714) 741-5312 | (714) 741-5578 fax
mariap@ci.garden-grove.ca.us | www.ci.garden-grove.ca.us

Community Development Department of the City of Garden Grove
"Providing Quality Services Through Creativity and Collaboration"

City Hall Hours:
Monday-Thursday: 7:30 a.m. to 5:30 p.m.
First Friday of the Month: 7:30 a.m. to 5:00 p.m.

Direct Website Links:
[Planning Division](#)
[Municipal Code, Title 9, Land Use](#)
[Zoning Map](#)

From: "Matthew Reid" <matt.reid@landanddesign.com>
To: "Jayna Morgan" <Jayna.Morgan@aecom.com>
Cc: "Alana Cheng" <alanac@ci.garden-grove.ca.us>, "Greg Blodgett" <greg1@ci.garden-grove.ca.us>, "Maria Parra" <mariap@ci.garden-grove.ca.us>
Sent: Tuesday, August 18, 2015 8:41:49 AM
Subject: Re: Agreement for Reimbursement - Land & Design, Inc.

Greg?

Sent from my iPhone

Matthew Reid
Land & Design, Inc.
3755 Avocado Blvd | #516 | LaMesa, CA 91941
619.567.2447 x101 office
858.735.1858 cell
619.489.3669 efax
Skype - matthew.reid.ca
matt.reid@landanddesign.com

Check out our new website www.landanddesign.com

On Aug 18, 2015, at 8:37 AM, Morgan, Jayna <Jayna.Morgan@aecom.com> wrote:

Thank you!

Please let us know ASAP.

I spoke with Maria last night and she does not want to hold the meeting until the deposit is with the city.

Best regards,

Jayna Morgan

Project Manager

Sent from my iPhone

On Aug 18, 2015, at 8:32 AM, Alana Cheng <alanac@ci.garden-grove.ca.us> wrote:

Good Morning Matt,

I just received the original agreement this morning. Did you have a chance to verify with your partner that the wire has been sent? Please let me know when you can.

Thanks,

Alana

From: "Matthew Reid" <matt.reid@landanddesign.com>

To: "Alana Cheng" <alanac@ci.garden-grove.ca.us>

Cc: "Greg Blodgett" <greg1@ci.garden-grove.ca.us>, "Jayna Morgan" <jayna.morgan@aecom.com>, "Maria Parra" <mariap@ci.garden-grove.ca.us>

Sent: Monday, August 17, 2015 10:42:37 AM

Subject: Re: Agreement for Reimbursement - Land & Design, Inc.

Agreement was put in the mail, a day or two and should be in your hands.

I'll verify with our partner the wire has been sent....

Matthew Reid

Land & Design, Inc.

3755 Avocado Blvd | #516 | LaMesa, CA 91942

858.735.1858 cell

Skype - [matthew.reid.ca](https://www.skype.com/user/matthew.reid.ca)

matt.reid@landanddesign.com

Check out our new website www.landanddesign.com

On Aug 17, 2015, at 10:40 AM, Alana Cheng
<alanac@ci.garden-grove.ca.us> wrote:

Hi Matt,

Please let me know if you wired the deposit on Friday so I can ask our Finance Department to verify. AECOM is coming tomorrow morning to meet with Maria. Also, I still have not received your original executed agreement.

Thank you,

Alana

From: "Alana Cheng" <alanac@ci.garden-grove.ca.us>
To: "Matthew Reid" <matt.reid@landanddesign.com>
Cc: "Greg Blodgett" <greg1@ci.garden-grove.ca.us>, "Jayna Morgan" <jayna.morgan@aecom.com>, "Karl Hill" <karlh@ci.garden-grove.ca.us>, "Maria Parra" <mariap@ci.garden-grove.ca.us>, "Susan Emery" <susan1@ci.garden-grove.ca.us>
Sent: Thursday, August 13, 2015 5:05:02 PM
Subject: Re: Agreement for Reimbursement - Land & Design, Inc.

Hi Matt,

Please find wiring instructions below:

Union Bank

ABA#: [REDACTED]

Credit to Account #: [REDACTED]

Account Name: City of Garden Grove - General Account

Beneficiary / Payee: City of Garden Grove

OBI: **Please see note below.**

** Please add the description for the deposit : **Site "C" CONSULTANT REIMBURSEMENT** so we can identify the money when it comes in.

Thank you,

Alana

From: "Matthew Reid" <matt.reid@landanddesign.com>
To: "Alana Cheng" <alanac@ci.garden-grove.ca.us>
Cc: "Greg Blodgett" <greg1@ci.garden-grove.ca.us>, "Jayna Morgan" <jayna.morgan@aecom.com>, "Karl Hill" <karlh@ci.garden-grove.ca.us>, "Maria Parra" <mariap@ci.garden-grove.ca.us>
Sent: Wednesday, August 12, 2015 11:14:11 AM
Subject: Re: Agreement for Reimbursement - Land & Design, Inc.

Attached signed agreement. Original is being sent via mail.
Can you forward wire instructions for deposit?

Matthew Reid

Land & Design, Inc.

3755 Avocado Blvd | #516 | LaMesa, CA 91942

858.735.1858 cell

Skype - [matthew.reid.ca](https://www.skype.com/user/matthew.reid.ca)

matt.reid@landanddesign.com

Check out our new website www.landanddesign.com

On Aug 4, 2015, at 11:18 AM, Alana Cheng
<alanac@ci.garden-grove.ca.us> wrote:

Hi all,

Please have this agreement executed and
mailed back to the City.

Let me know if you have questions.

Thanks,
Alana
<Land & Design, Inc.CEQA REVIEW
REIMBURSEMENT AGREEMENT w. AECOM
7.28.15.doc>

Subject: VisitAnaheim2013-2015Attendance[1].xlsx
From: Greg Blodgett <greg1@ci.garden-grove.ca.us>
Date: Tue, 18 Aug 2015 10:45:34 -0700 (PDT)
To: Matthew Reid <matt.reid@landanddesign.com>

Sent from my iPhone

VisitAnaheim2013-2015Attendance[1].xlsx	Content-Type: application/vnd.openxmlformats-officedocument.spreadsheetml.sheet Content-Encoding: base64
--	---

Part 1.3

Part 1.3	Content-Type: text/plain Content-Encoding: 7bit
-----------------	--



Conventions and Meetings Estimated and Projected Attendance 2013 - 2015

ATTENDANCE - BY MONTH/YEAR									
Month	Conventions			Meetings			TOTAL		
	2013	2014	2015	2013	2014	2015	2013	2014	2015
JAN	101,000	108,800	115,000	13,750	18,450	17,182	114,750	127,250	132,182
FEB	87,100	60,000	40,000	26,665	25,270	46,265	113,765	85,270	86,265
MAR	102,600	161,500	173,500	27,404	70,821	32,550	130,004	232,321	206,050
APR	79,300	96,900	143,000	25,391	16,895	27,518	104,691	113,795	170,518
MAY	19,500	46,000	18,100	32,322	15,792	20,355	51,822	61,792	38,455
JUN	17,100	25,200	41,800	36,520	41,330	14,845	53,620	66,530	56,645
JUL	19,500	3,800	31,100	35,380	25,496	32,545	54,880	29,296	63,645
AUG	50,000	12,000	68,000	100,785	30,600	48,915	150,785	42,600	116,915
SEP	8,400	17,500	41,000	36,840	34,654	46,982	45,240	52,154	87,982
OCT	15,600	35,500	28,500	24,020	20,685	48,509	39,620	56,185	77,009
NOV	31,000	52,800	30,000	36,936	43,630	26,735	67,936	96,430	56,735
DEC	9,800	0	0	24,630	13,520	33,525	34,430	13,520	33,525
TOTAL	540,900	620,000	730,000	420,643	357,143	395,926	961,543	977,143	1,125,926

= Projected

ATTENDANCE - YTD									
Month	Conventions			Meetings			TOTAL		
	2013	2014	2015	2013	2014	2015	2013	2014	2015
JAN	101,000	108,800	115,000	13,750	18,450	17,182	114,750	127,250	132,182
FEB	188,100	168,800	155,000	40,415	43,720	63,447	228,515	212,520	218,447
MAR	290,700	330,300	328,500	67,819	114,541	95,997	358,519	444,841	424,497
APR	370,000	427,200	471,500	93,210	131,436	123,515	463,210	558,636	595,015
MAY	389,500	473,200	489,600	125,532	147,228	143,870	515,032	620,428	633,470
JUN	406,600	498,400	531,400	162,052	188,558	158,715	568,652	686,958	690,115
JUL	426,100	502,200	562,500	197,432	214,054	191,260	623,532	716,254	753,760
AUG	476,100	514,200	630,500	298,217	244,654	240,175	774,317	758,854	870,675
SEP	484,500	531,700	671,500	335,057	279,308	287,157	819,557	811,008	958,657
OCT	500,100	567,200	700,000	359,077	299,993	335,666	859,177	867,193	1,035,666
NOV	531,100	620,000	730,000	396,013	343,623	362,401	927,113	963,623	1,092,401
DEC	540,900	620,000	730,000	420,643	357,143	395,926	961,543	977,143	1,125,926

= Projected

CONVENTIONS = Visit Anaheim Bookings in the ACC with 1,000 Rooms or greater on Peak (Original Est.)

MEETINGS = Visit Anaheim Bookings with less than 1,000 Rooms on Peak (Original Est.)

****Meetings Data only represent business booked into Anaheim and Garden Grove****

****All Attendance Numbers are Estimates****

Re: Thank you

Subject: Re: Thank you

From: Scott Stiles <sstiles@ci.garden-grove.ca.us>

Date: Wed, 19 Aug 2015 09:00:51 -0700 (PDT)

To: Matthew Reid <matt.reid@landanddesign.com>

CC: David Rose <drose3@charter.net>, Greg Blodgett <Greg1@ci.garden-grove.ca.us>

Matthew:

Yes...good to meet you guys, and thanks to you and Dave for taking the time to come in and update me on the project status. Very exciting stuff. Looking forward to working closely with you as we go forward. Please feel free to call or email me anytime. Regards,
Scott

Scott C. Stiles, ICMA-CM
City Manager / City of Garden Grove
11222 Acacia Parkway
Garden Grove, CA 92840
714-741-5100 (o) / 714-719-1810 (c)
www.ci.garden-grove.ca.us

----- Original Message -----

From: "Matthew Reid" <matt.reid@landanddesign.com>

To: sstiles@ci.garden-grove.ca.us

Cc: "David Rose" <drose3@charter.net>, "Greg Blodgett" <Greg1@ci.garden-grove.ca.us>

Sent: Wednesday, August 19, 2015 8:50:37 AM

Subject: Thank you

Scott,

Thank you for meeting with Dave and me yesterday regarding our exciting project in Garden Grove.

We look forward to working with you, and your staff to push this over the finish line in the coming months.

Thank you again

Matthew Reid
Land & Design, Inc.
3755 Avocado Blvd | #516 | LaMesa, CA 91942
858.735.1858 cell
Skype - matthew.reid.ca
matt.reid@landanddesign.com

Check out our new website www.landanddesign.com

Subject: Site "C" Meeting Update

From: Maria Parra <mariap@ci.garden-grove.ca.us>

Date: Wed, 19 Aug 2015 10:10:40 -0700 (PDT)

To: Matthew Reid <matt.reid@landanddesign.com>, Dave Rose <drose3@charter.net>, zkhan@langdonwilson.com, Karl Hill <karlh@ci.garden-grove.ca.us>, Lee Marino <leem@ci.garden-grove.ca.us>, Greg Blodgett <greg1@ci.garden-grove.ca.us>, jayan.morgan@aecom.com, Jane Chang <jane.chang@aecom.com>

All:

Below is a summary of the items necessary to proceed with the CEQA addendum and the Site Plan review.

L&D to:

- Submit to Planning and AECOM a revised project summary per Table 1 of the Mitigated Negative Declaration (see attached MND Table 1 Project Summary).
- Submit a revised, detailed site plan, and building sections to Planning and AECOM. Planning will review the plans with Fire, Building, and Engineering. The plans must also include the proposed building LED sign location(s), dimensions, and square footage. Planning staff will review and discuss the proposed LED signs internally with the policymakers.
- The proposed LED signs will require a light and glare study that will be submitted to AECOM. The LED signs will require an amendment to the PUD.
- To provide a project schedule timeline

I have attached a copy of the Harbor Blvd sidewalk standard and landscaping, and a copy of the Tentative Parcel Map.

Best regards,

Maria Parra

Urban Planner

City of Garden Grove | Planning Services Division

11222 Acacia Parkway, Garden Grove, CA 92840

(714) 741-5312 | (714) 741-5578 fax

mariap@ci.garden-grove.ca.us | www.ci.garden-grove.ca.us

Community Development Department of the City of Garden Grove

"Providing Quality Services Through Creativity and Collaboration"

City Hall Hours:

Monday-Thursday: 7:30 a.m. to 5:30 p.m.

First Friday of the Month: 7:30 a.m. to 5:00 p.m.

Direct Website Links:

[Planning Division](#)

[Municipal Code, Title 9, Land Use](#)

[Zoning Map](#)

MND Table Summary.pdf	Content-Type: application/pdf Content-Encoding: base64
------------------------------	---

— Tentative Tract Map.pdf —

Tentative Tract Map.pdf	Content-Type: application/pdf Content-Encoding: base64
--------------------------------	---

— Harbor Sidewalk and Landscape.pdf —

Harbor Sidewalk and Landscape.pdf	Content-Type: application/pdf Content-Encoding: base64
--	---

- General Plan Amendment No. GPA-2-12(B) to change the General Plan Land Use designation of two (2) residential properties along Twintree Lane (12251 and 12571 Twintree Lane; APN: 231-521-09 and 231-521-10) and four (4) residential properties) along Choisser Road (12233, 12235, 12237, and 12239 Choisser Road; APN: 231-491-12, 13, 14, 15, 16, 17, 18, & 19) from Low Density Residential to International West Mixed Use with an accompanying zone change from R-1 to PUD;
- Establishing a Planned Unit Development zoning with development standards –; eight (8) lots along Harbor Boulevard (2222, 12202, 12252, 12262, 12272, 12292, and 12302 Harbor Boulevard; APN: 231-491-20 & 21, 231-521-01, 02, 03, 04, 05, & 06; and two (2) lots along Twintree Lane (12511 and 12531 Twintree Lane; APN: 231-521-07 and 08) will be rezoned from HCSP-TZN to PUD, while two (2) residential properties along Twintree Lane (12251 and 12571 Twintree Lane, APN: 231-521-09 and 10) and four (4) residential properties along Choisser Road (12233, 12235, 12237 and 12239 Choisser Road, APN: 231-491-12, 13, 14, 15, 16, 17, 18, & 19) will be rezoned from R-1 to PUD to provide consistency with the current International West Mixed Use General Plan Designation. The PUD will include all necessary requirements so a Site Plan/Land Use Permit application will not be required;
- Tentative Tract Map No. 17455 (see Figure 7, Existing Easements Data Map and Figure 8, Post Development Condition Map) and Development Agreement No. DA-185-12 are integral parts of the project. They will be considered at a future date by Planning Commission and City Council; and
- A future Conditional Use Permit, to allow for the sale of alcoholic beverages in the hotel, hotel restaurants, and freestanding restaurants, will be considered at a future date by the Planning Commission.

Table 1
Project Summary

Total Hotel Rooms (one full-service and two limited-service)	769 keys/rooms
Full-Service Hotel (max. height)	263 ft
Harbor Limited-Service Hotel (max. height)	200 ft
Twintree Limited-Service Hotel (max. height)	130 ft (E. side) to 190 ft (W. side)
Parking Structure / Ballroom & Pre Function (max. height)	85 ft
Parking Structure (East Side) (max. height)	75 ft
Restaurants Off Harbor (max. height) (max. height)	40 ft
Restaurant/Venue Northeast Corner (max. height)	75 ft
Restaurant/Entertainment (four pads @ 7,500 sf and one pad @ 15,000 sf)	45,000 sf

Hotel Restaurant	20,000 sf
Additional Hotel Ancillary	Restaurant, Bars, Fitness Rooms and Spa
Conference/Meeting Banquet	39,000 sf
Parking Spaces Provided	1,297

10. OTHER AGENCIES WHOSE APPROVAL (AND PERMITS) IS REQUIRED:

City of Garden Grove Planning Commission

City of Garden Grove City Council

TENTATIVE TRACT MAP 17455 FOR CONDOMINIUM PURPOSES

BEING A SUBDIVISION OF PORTION OF W. 1/2, NW 1/4, NE 1/4, SECTION 34, T4S, R10W AND PORTION OF NE 1/4, SW 1/4, NE 1/4, SECTION 34, T4S, R10W IN THE CITY OF GARDEN GROVE, COUNTY OF ORANGE, STATE OF CALIFORNIA.
(DETAILED LEGAL DESCRIPTION AS SHOWN ON SHEET 2)

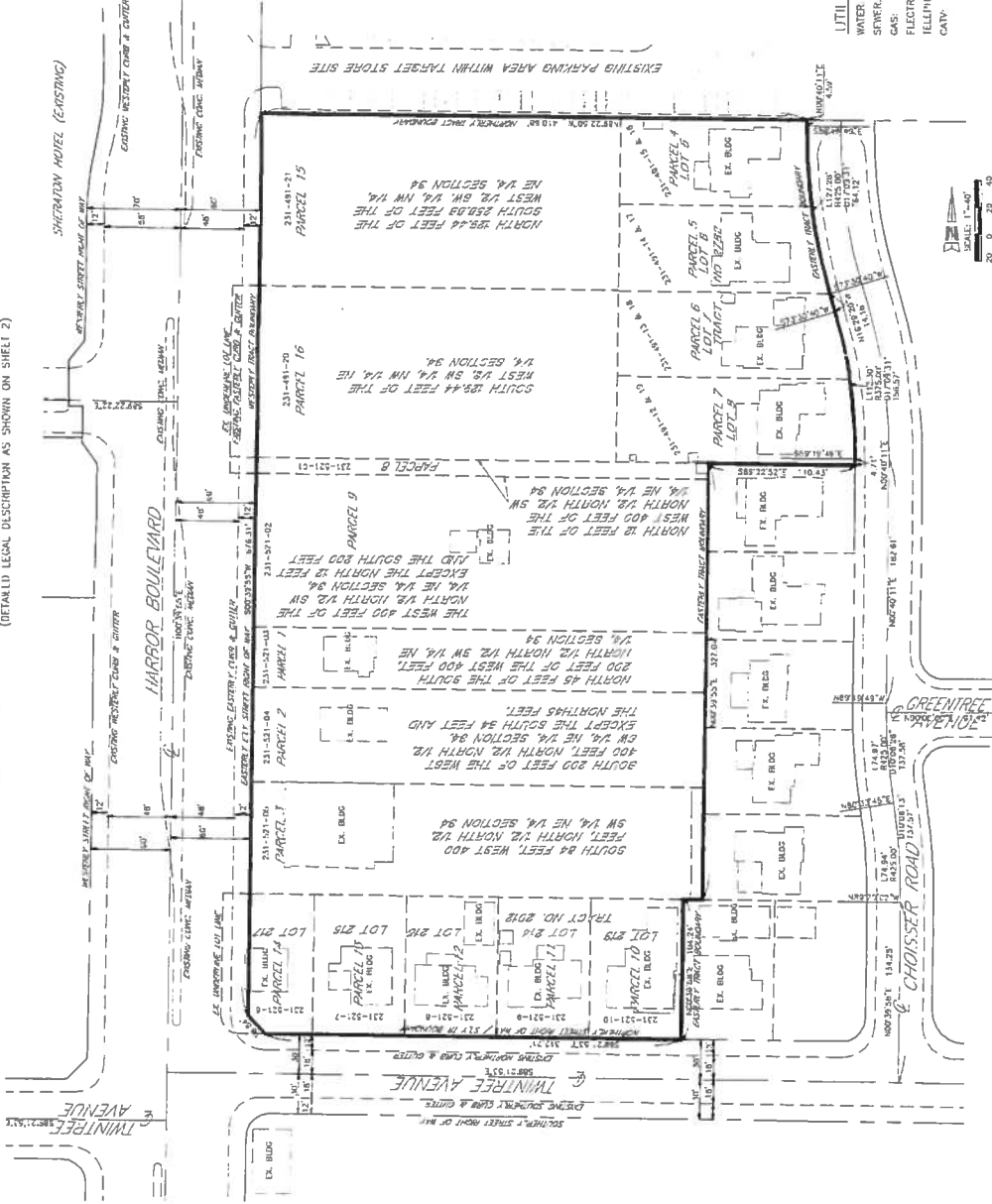

- SHEET INDEX**
- SHEET 1: CONCEPT SITE DESCRIPTION
 - SHEET 2: INITIAL SITE DESCRIPTION
 - SHEET 3: EXISTING SITE DESCRIPTION
 - SHEET 4: CONCEPT SITE DESCRIPTION
 - SHEET 5: CONCEPT SITE DESCRIPTION
 - SHEET 6: CONCEPT SITE DESCRIPTION
 - SHEET 7: CONCEPT SITE DESCRIPTION
 - SHEET 8: CONCEPT SITE DESCRIPTION

GENERAL NOTES:

1. EXISTING AND PROPOSED EASEMENTS, ENCUMBRANCES, AND EASEMENTS ARE SHOWN ON SHEET 1.
2. THE PROPOSED PROJECT, INCLUDING EXISTING AND PROPOSED EASEMENTS, IS SHOWN ON SHEET 1.
3. TOTAL TRACT GROSS AREA = 5.866 ACRES.
4. TOTAL TRACT NET AREA = 5.866 ACRES.
5. ALL AREAS SHOWN ARE APPROXIMATE AND SHOULD BE VERIFIED BY THE APPLICANT.
6. ALL AREAS SHOWN ARE APPROXIMATE AND SHOULD BE VERIFIED BY THE APPLICANT.
7. ALL AREAS SHOWN ARE APPROXIMATE AND SHOULD BE VERIFIED BY THE APPLICANT.

LEGEND:

- EXISTING PROPERTY
- PROPOSED PROJECT
- PROPOSED EASEMENTS
- PROPOSED ENCUMBRANCES
- PROPOSED EASEMENTS
- PROPOSED ENCUMBRANCES
- PROPOSED EASEMENTS
- PROPOSED ENCUMBRANCES
- PROPOSED EASEMENTS
- PROPOSED ENCUMBRANCES

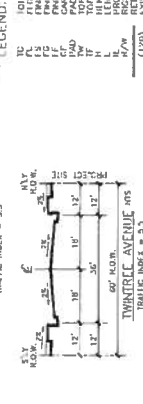
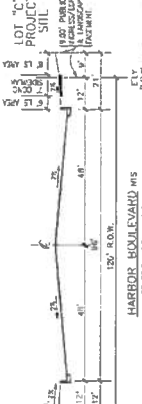

- UTILITY PROVIDERS:**
- CITY OF GARDEN GROVE (714) 741-5395
 - O.C. SANITARY DIST. (714) 982-2411
 - SOUTHERN CALIFORNIA GAS CO. (714) 534-3052
 - SOUTHERN CALIFORNIA Edison CO. (714) 973-5449
 - PACIFIC BELL (714) 969-5440
 - TIME WARNER COMMUNICATIONS (714) 903-8307

NO.	DATE	DESCRIPTION
1		PRELIMINARY
2		REVISED
3		REVISED
4		REVISED
5		REVISED
6		REVISED
7		REVISED
8		REVISED
9		REVISED
10		REVISED
11		REVISED
12		REVISED
13		REVISED
14		REVISED
15		REVISED
16		REVISED
17		REVISED
18		REVISED
19		REVISED
20		REVISED

<p>CITY OF GARDEN GROVE</p> <p>TENTATIVE TRACT 17455 (FOR CONDOMINIUM PURPOSES)</p> <p>TITLE SHEET EXISTING SITE CONDITION FINAL DRAFT (REVISION 1A)</p> <p>APPROVED:</p>	<p>CIVIL ENGINEER:</p> <p>FOCUS ENGINEERING, INC. CIVIL ENGINEERS 1440 SANITARY GARDEN GROVE, CA 92703 TEL: (714) 982-2411 FAX: (714) 982-2411 E-MAIL: focuseng@focuseng.com</p> <p>PROJECT PLANNER:</p> <p>ACTCOM 925 W. HORN AND COUNTRY ROAD LUNDA, CA 92703 TEL: (714) 982-2411 FAX: (714) 982-2411 E-MAIL: www.actcom.com</p> <p>OWNER:</p> <p>GROVE AGENCY FOR COMMUNITY DEVELOPMENT 11222 ACORN PARKWAY CANAVERAL CITY, FL 32910 TEL: (714) 341-2150 FAX: (714) 341-2150 E-MAIL:</p>
--	--

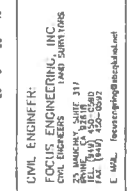

TENTATIVE TRACT MAP 17455 FOR CONDOMINIUM PURPOSES

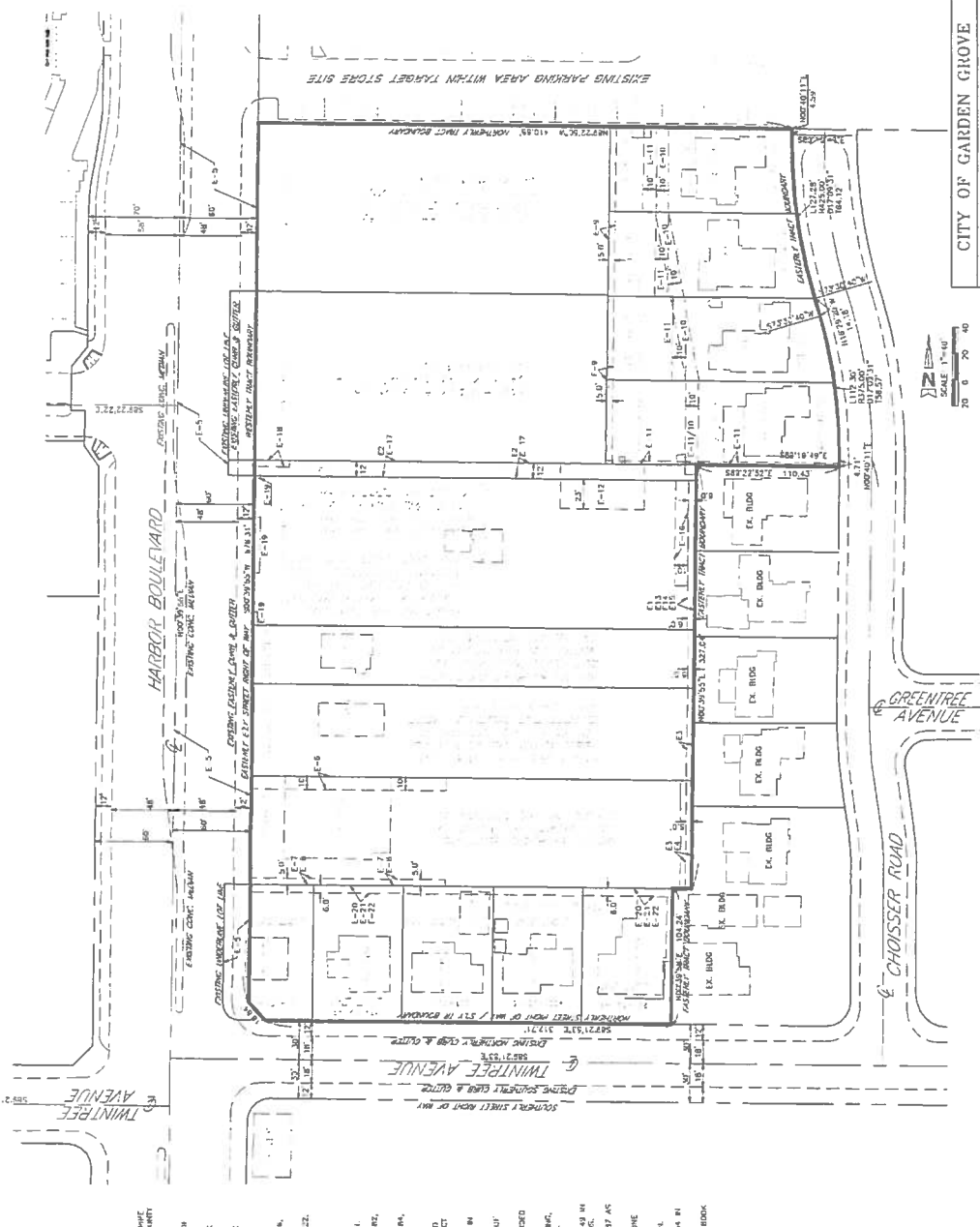

EXISTING EASEMENT NOTES:

- E-1 INDICATES AN EASEMENT FOR THE OPERATION AND MAINTENANCE OF WATER MAINS AS SHOWN ON MAP 17455, RECORDS 2012 07 20.
- E-2 INDICATES A 12-FOOT EGRESS AND PUBLIC UTILITIES EASEMENT AS SHOWN ON A MAP OF ORANGE, STATE OF CALIFORNIA, RECORDS 2012 07 20.
- E-3 INDICATES AN EASEMENT FOR PALE LINES AND CONDUITS AND INCIDENTAL PURPOSES, RECORDED IN BOOK 3333, PAGE 91, OF OFFICIAL RECORDS.
- E-4 INDICATES AN EASEMENT FOR PALE LINES AND CONDUITS AND INCIDENTAL PURPOSES, RECORDED IN BOOK 3057, PAGE 117, OF OFFICIAL RECORDS.
- E-5 INDICATES AN EASEMENT FOR STREET AND HIGHWAY AND INCIDENTAL PURPOSES FOR VARIETY RECREATION, RECORDED IN BOOK 1124, PAGE 11.
- E-6 INDICATES AN EASEMENT FOR WALKS AND HIGHWAY, RECORDED IN BOOK 1122, PAGE 1195, OF OFFICIAL RECORDS.
- E-7 INDICATES AN EASEMENT FOR WALKS AND EGRESS AND INCIDENTAL PURPOSES, RECORDED IN BOOK 1122, PAGE 1195, OF OFFICIAL RECORDS.
- E-8 INDICATES AN EASEMENT OF PUBLIC UTILITIES AND INCIDENTAL PURPOSES, RECORDED APRIL 8, 1989 AS INSTRUMENT NO. 89-17484, OF OFFICIAL RECORDS.
- E-9 INDICATES AN EASEMENT OF PUBLIC UTILITIES AND INCIDENTAL PURPOSES, RECORDED IN BOOK 1880, PAGE 289, OF OFFICIAL RECORDS.
- E-10 INDICATES AN EASEMENT FOR PALE LINES AND INCIDENTAL PURPOSES, RECORDED IN BOOK 3531, PAGE 342, OF OFFICIAL RECORDS.
- E-11 INDICATES AN EASEMENT FOR PALE LINES AND INCIDENTAL PURPOSES, RECORDED IN BOOK 1542, PAGE 304, OF OFFICIAL RECORDS.
- E-12 INDICATES RIGHTS AND EGRESS OF WAY, RECORDED MAY 7, 1919 IN BOOK 333, PAGE 107, OF DEEDS. IT CONTAINS A PARCEL DESCRIBED AS A TRAP SHED WITH SHARED INTERESTS, WHICH CAN BE DIVIDED INTO TWO PARCELS. LOCATION CANNOT BE DETERMINED FROM RECORDS.
- E-13 INDICATES AN EASEMENT FOR WATER PIPES AND INCIDENTAL PURPOSES, RECORDED SEPTEMBER 13, 1949 IN BOOK 1800, PAGE 289, OF OFFICIAL RECORDS.
- E-14 INDICATES THE RIGHT TO USE A PUMP, RECORDED SEPTEMBER 13, 1949 IN BOOK 1800, PAGE 290, OF OFFICIAL RECORDS.
- E-15 INDICATES AN EASEMENT FOR WALKS ON BOTH SIDE LINES, CONDUITS AND INCIDENTAL PURPOSES, RECORDED IN BOOK 3037, PAGE 116, OF OFFICIAL RECORDS.
- E-16 INDICATES THE TERMS AND CONDITIONS OF A PUMPING PLANT AGREEMENT RELATIVE TO A WELL AND PUMPING, RECORDED ON OTHER LAND, RECORDED NOVEMBER 6, 1957, IN BOOK 2250, PAGE 355, OF OFFICIAL RECORDS.
- E-17 INDICATES AN EASEMENT FOR WALKS AND CONDUITS AND PUBLIC UTILITIES, RECORDED SEPTEMBER 13, 1949 IN BOOK 1800, PAGE 289, AND NOVEMBER 4, 1949 IN BOOK 1534, PAGE 304, BOTH OF OFFICIAL RECORDS.
- E-18 INDICATES AN EASEMENT FOR PUBLIC UTILITIES AND INCIDENTAL PURPOSES, RECORDED NOVEMBER 23, 1987 AS INSTRUMENT NO. 87-05045, OF OFFICIAL RECORDS.
- E-19 INDICATES AN EASEMENT FOR WALKS AND CONDUITS AND INCIDENTAL PURPOSES, RECORDED JUNE 1987 AS INSTRUMENT NO. 87-05045, OF OFFICIAL RECORDS.
- E-20 INDICATES AN EGRESS EASEMENT OR DEDICATED ON THE MAP AS REFERRED TO IN THE LEGAL DESCRIPTION.
- E-21 INDICATES AN EGRESS EASEMENT FOR PUBLIC UTILITIES AND INCIDENTAL PURPOSES, RECORDED FEBRUARY 10, 1954 IN BOOK 2047, PAGE 2, OF OFFICIAL RECORDS.
- E-22 INDICATES AN EASEMENT FOR PUBLIC UTILITIES AND INCIDENTAL PURPOSES, RECORDED APRIL 6, 1954 IN BOOK 2754, PAGE 206, OF OFFICIAL RECORDS.
- E-23 INDICATES AN EASEMENT FOR PUBLIC UTILITIES AND INCIDENTAL PURPOSES, RECORDED MAY 26, 1987, AS INSTRUMENT NO. 87-23465, OF OFFICIAL RECORDS.

CITY OF GARDEN GROVE	
TENTATIVE TRACT MAP 17455 (FOR CONDOMINIUM PURPOSES)	
EXISTING EASEMENTS DATA	SHEET 3 OF 8
FINAL DRAFT (REVISION 1A)	
APPROVED: 2012 07 20 REVISIONS: 2012 07 20 DATE: 2012 07 20	

NO.	DATE	REVISIONS



CIVIL ENGINEER:
CECIL A. DINKENS, INC.
25, MALDEN, SUITE 317
MILPITAS, CA 95035
TEL: (415) 221-9980
FAX: (415) 250-0572
E-MAIL: cecid@cecidinc.com

PROJECT PLANNER:
ACCOM
13222 ACADEMY ROAD
DUNSMIRE, CA 95008-4713
TEL: (415) 221-9980
FAX: (415) 250-2441
E-MAIL: www.accom.com

OWNER:
GARDEN GROVE AGENCY FOR
COMMUNITY DEVELOPMENT
13222 ACADEMY ROAD
DUNSMIRE, CA 95008-4713
TEL: (415) 221-9980
FAX: (415) 241-5138
E-MAIL: www.gardengrove.org

TENTATIVE TRACT 17455

SHERATON HOTEL

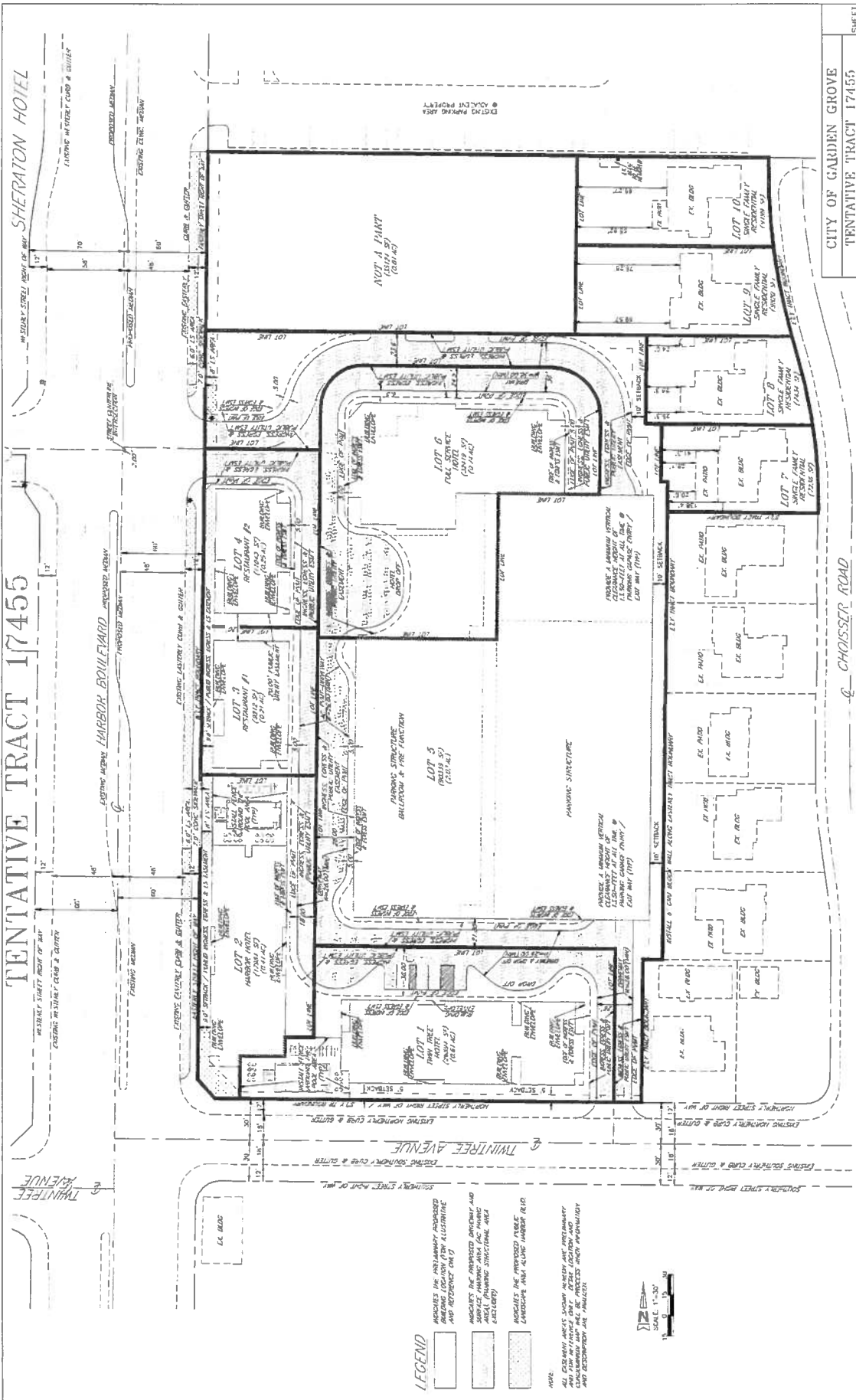

OWNER: GARDEN GROVE AGENCY FOR COMMUNITY DEVELOPMENT 1122 ADINA HIGHWAY GARDEN GROVE, CA 92640 TEL: (714) 741-3100 FAX: (714) 741-3126 E-MAIL:		PROJECT PLANNER: AECOM 1000 AVENUE OF THE STARS, SUITE 1000 GARDEN GROVE, CA 92640-3111 TEL: (714) 947-2561 FAX: (714) 947-4744 E-MAIL: www.aecom.com		CIVIL ENGINEER: CIVIL US ENGINEERING, INC. 2300 S. STATE ST. SUITE 100 GARDEN GROVE, CA 92640 TEL: (714) 947-2561 FAX: (714) 947-4744 E-MAIL: foos@engrplus.com	
LEGEND [Symbol] INDICATES THE INSTRUMENT PROPOSED AND IS NOT A REQUIREMENT FOR ALTERNATIVE AND RETENTION ONLY [Symbol] INDICATES THE PROPOSED STRUCTURE AND IS NOT A REQUIREMENT FOR ALTERNATIVE AND RETENTION ONLY [Symbol] INDICATES THE PROPOSED TABLE LANDSCAPE AND IS NOT A REQUIREMENT FOR ALTERNATIVE AND RETENTION ONLY		REVISIONS NO. DATE DESCRIPTION 1 10/10/00		CITY OF GARDEN GROVE TENTATIVE TRACT 17455 (FOR CONDOMINIUM PURPOSES) POST DEVELOPMENT CONDITION FINAL DRAFT (REVISION 1A) APPROVED PREPARED: 10/10/00 REVISION: 10/10/00 DATE: 10/10/00	

TENTATIVE TRACT 17455

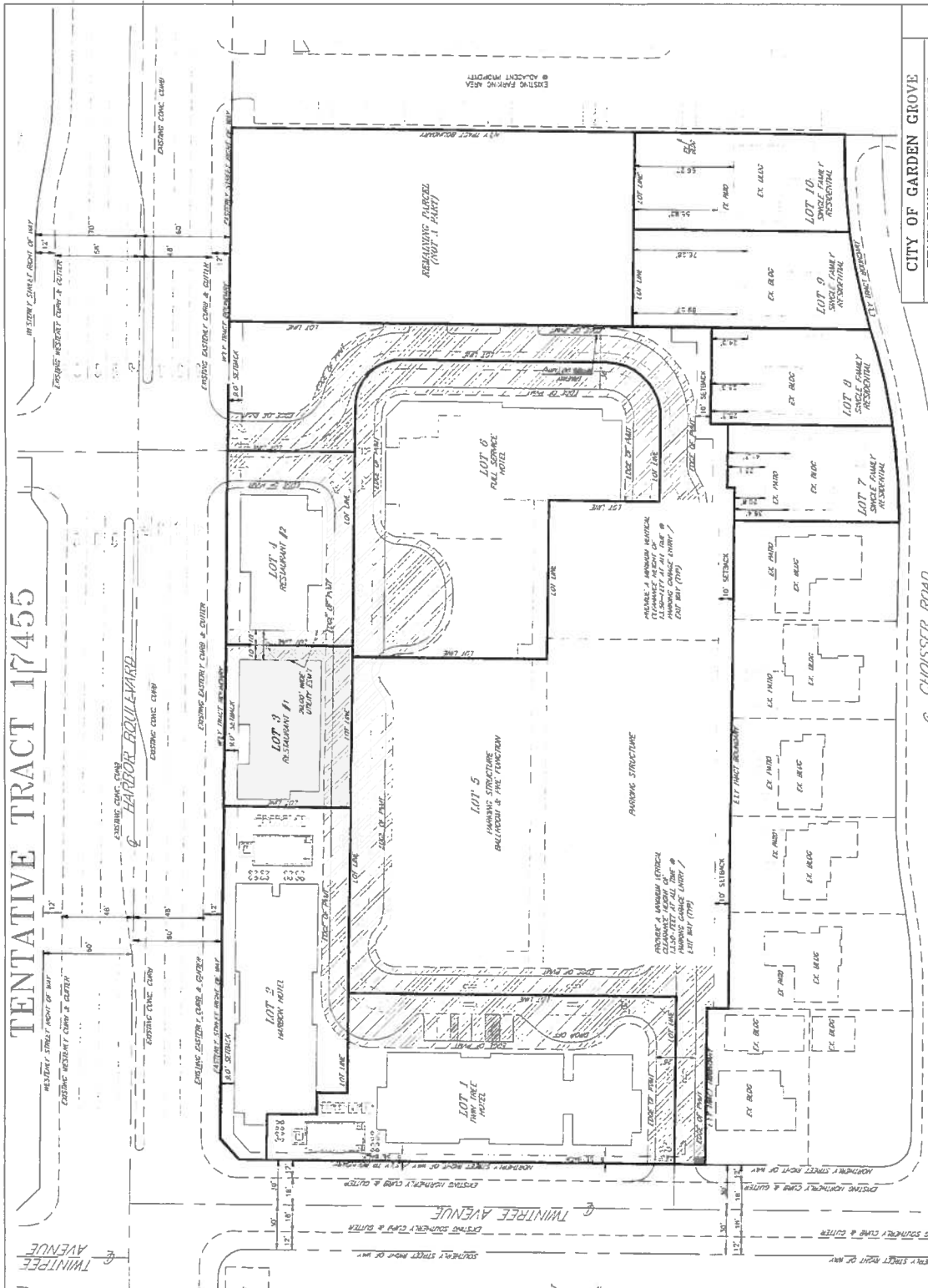

RESERVED PARKING (LOT 1 PART)

CITY OF GARDEN GROVE
 TENTATIVE TRACT 17455
 FOR COMMUNITY DEVELOPMENT
 EXHIBIT OF PROPOSED EASEMENT - PART A
 INGRESS, EGRESS, UTILITY
 AND RECIPROCAL PARKING
 FINAL DRAFT (REVISION 1A)
 APPROVED
 PREPARED: 2012-07-20
 DATE: 2012-07-20

REVISIONS

NO.	DATE	DESCRIPTION



CIVIL ENGINEER:
 FOCUS ENGINEERING, INC.
 CIVIL ENGINEERS
 AND SURVEYORS
 25 MANUEL S. SIRE 317
 TOLSON AVENUE, SUITE 100
 TOLSON, CA 92688
 TEL: (714) 455-0800
 FAX: (714) 455-0800
 E-MAIL: focusengr@focusengr.com

PROJECT PLANNER
 ACCOM
 999 N. TOWN AND COUNTRY ROAD
 UPLAND, CA 91786-1113
 TEL: (916) 867-2441
 FAX: (916) 867-2441
 E-MAIL: acccom@aacom.com

OWNER: GARDEN GROVE AGENCY FOR
 COMMUNITY DEVELOPMENT
 10000 TWIN TREE AVENUE
 GARDEN GROVE, CA 92640
 TEL: (714) 741-5100
 FAX: (714) 741-5106
 E-MAIL: ggcdev@cityofgarden Grove.org

- LEGEND**
- RESERVED PARKING AREAS
 - RESERVED PARKING AREAS
 - RESERVED PARKING AREAS
 - RESERVED PARKING AREAS
 - RESERVED PARKING AREAS
 - RESERVED PARKING AREAS
- NOTE:**
 ALL LOTSWAY AREAS SHOWN HEREIN ARE THE PROPERTY OF THE CITY OF GARDEN GROVE AND ARE RESERVED FOR THE USE OF THE CITY OF GARDEN GROVE AND RECREATION AREAS.



TENTATIVE TRACT 17455

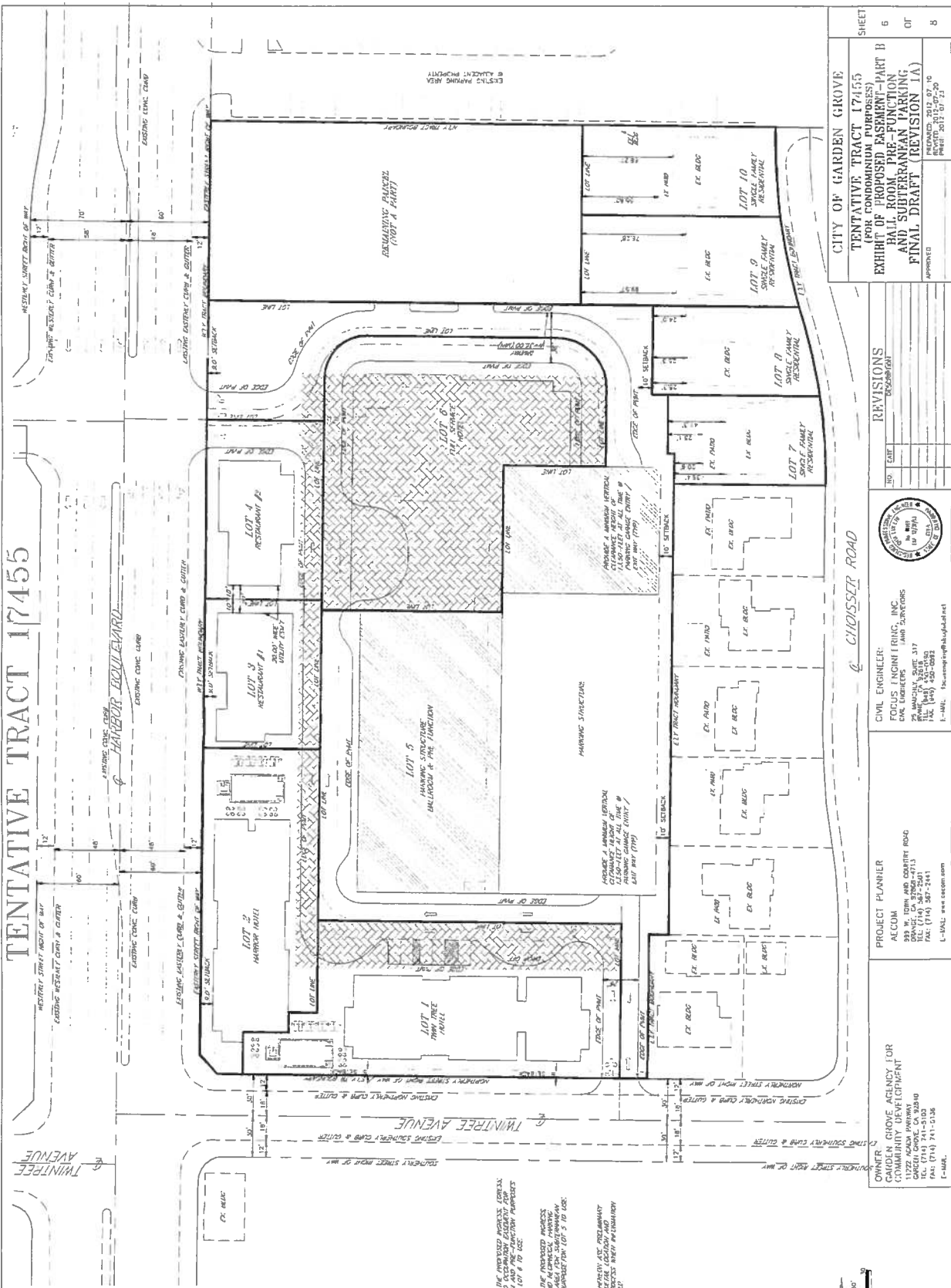

LEGEND

- INDICATES THE PROPOSED IMPROVEMENTS, EXCEPT FOR THE EXISTING CONCRETE DRIVE AND CONC. DRIVE WHICH ARE SHOWN FOR REFERENCE PURPOSES ONLY.
- INDICATES THE PROPOSED IMPROVEMENTS, EXCEPT FOR THE EXISTING CONCRETE DRIVE AND CONC. DRIVE WHICH ARE SHOWN FOR REFERENCE PURPOSES ONLY.
- ALL EXISTING UTILITIES SHOWN ARE NOT TO BE MOVED OR DELETED UNLESS SHOWN OTHERWISE. ALL UTILITIES SHOWN ARE NOT TO BE MOVED OR DELETED UNLESS SHOWN OTHERWISE.

CITY OF GARDEN GROVE
 TENTATIVE TRACT 17455
 (FOR THE PROPOSED DEVELOPMENT OF)
 EXHIBIT OF PROPOSED DEVELOPMENT PART B
 AND SUBMITTAL PARKING
 FINAL DRAFT (REVISION 1A)
 SHEET 6 OF 8
 APPROVED: [Signature] DATE: 03/12/2011
 PREPARED BY: [Signature] DATE: 03/12/2011

NO.	DATE	REVISIONS



CIVIL ENGINEER:
 JULIUS F. MAGINITO, INC.
 25 MARSHALL STREET, SUITE 317
 GARDEN GROVE, CA 92640
 TEL: (714) 587-5001
 FAX: (714) 587-5002
 E-MAIL: jfm@juliusmaginito.com

PROJECT PLANNER:
 ACCOM
 11222 ACORN DRIVE, SUITE 201
 GARDEN GROVE, CA 92640
 TEL: (714) 587-5001
 FAX: (714) 587-5002
 E-MAIL: acc@accom.com

OWNER: GARDEN GROVE AGENCY FOR
 COMMUNITY DEVELOPMENT
 11222 ACORN DRIVE, SUITE 201
 GARDEN GROVE, CA 92640
 TEL: (714) 587-5001
 FAX: (714) 587-5002
 E-MAIL: [Email Address]

TENTATIVE TRACT 17455

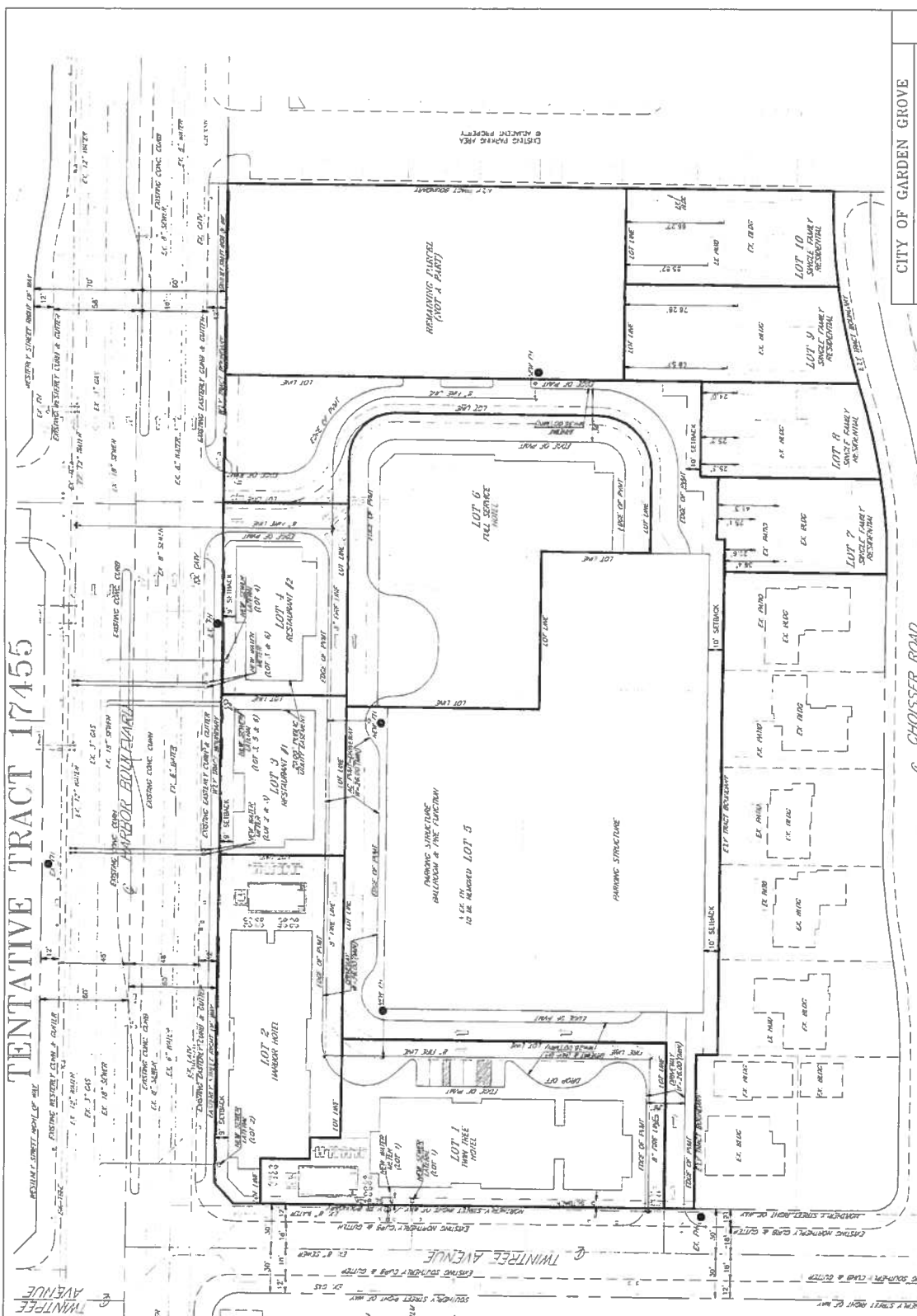

- LEGEND**
- ARCHITECT EXISTING POWER SYSTEM
 - ARCHITECT EXISTING GAS SYSTEM
 - ARCHITECT EXISTING TELEPHONE SYSTEM
 - ARCHITECT EXISTING WATER SYSTEM
 - ARCHITECT EXISTING STORM WATER SYSTEM
 - ARCHITECT EXISTING STORM SEWER SYSTEM
 - ARCHITECT PROPOSED WATER MAIN FOR ILLINOIS & ILLINOIS, ETC.
 - ARCHITECT PROPOSED STORM SEWER LATERAL

CITY OF GARDEN GROVE
TENTATIVE TRACT 17455
(FOR CONDOMINIUM PURPOSES)
EXISTING UTILITIES PLAN AND
PROPOSED WATER AND SEWER LINES
FINAL DRAFT (REVISION 1A)

NO.	DATE	REVISIONS



CIVIL ENGINEER:
LOCIS ENGINEERING, INC.
CIVIL ENGINEER
LAND SURVEYORS
25 MARSHALLS CREEK 317
DUBLIN, CA 94568
TEL: (916) 435-1500
FAX: (916) 435-5893
E-MAIL: locisengr@earthlink.net

PROJECT PLANNER:
AECOM
888 N. STATE AVE. COUNTRY ROAD
DUBLIN, CA 94568-7113
TEL: (916) 585-2441
FAX: (916) 585-2441
E-MAIL: www.aecom.com

OWNER:
GARDEN GROVE AGENCY FOR
COMMUNITY DEVELOPMENT
3000 N. STATE AVE. SUITE 100
GARDEN GROVE, CA 92640
TEL: (714) 241-3100
FAX: (714) 241-3108
E-MAIL:

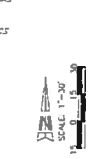

APPROVED
PREPARED: 2015.10.10
REVISED: 2017.07.20
PRINTED: 2017.07.20
FILE: 17455.DWG

TENTATIVE TRACT 17455

SHERATON HOTEL

WINTER STREET, NORTH OF MAP

17455

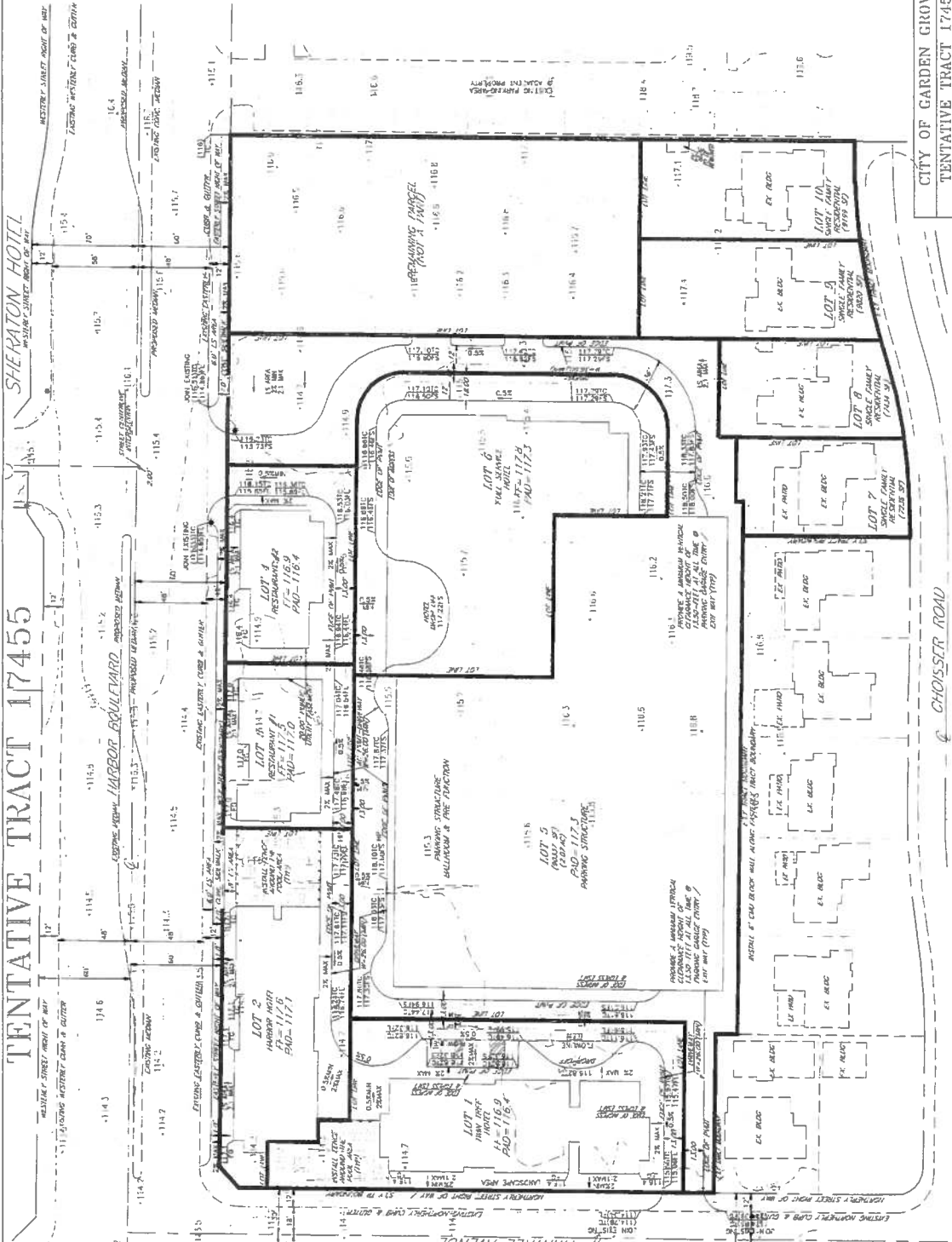

CITY OF GARDEN GROVE
TENTATIVE TRACT 17455
(FOR CONDOMINIUM PURPOSES)
CONCEPTUAL GRADING PLAN
FINAL DRAFT (REVISION 1A)

REVISIONS

NO.	DATE	DESCRIPTION

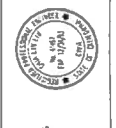

CIVIL ENGINEER
FOCUS ENGINEERING, INC.
2500 W. 17TH AVENUE, SUITE 117
DENVER, CO 80202
TEL: (303) 440-8888
FAX: (303) 440-0888
E-MAIL: focusengr@focusengr.net

PROJECT PLANNER
ALCOCK
11222 ACHUA PARKWAY
DENVER, CO 80242
TEL: (303) 487-2501
FAX: (303) 487-2501
E-MAIL: www.alcock.com

OWNER:
GARDEN GROVE AGENCY FOR
COMMUNITY DEVELOPMENT
11222 ACHUA PARKWAY
DENVER, CO 80242
TEL: (303) 741-5100
FAX: (303) 741-5138
E-MAIL:

NOTICE:
ALL EXISTING AND PROPOSED GRADES ARE BASED UPON THE
CONDOMINIUM MAP AND ALL PROCEEDINGS AND PERMITS
AND ORDINANCES ARE SUBJECT TO

APPROVED
REVISION 1A
DATE: 2012.07.20
DRAWN BY: [Name]
CHECKED BY: [Name]
SCALE: 1" = 30'

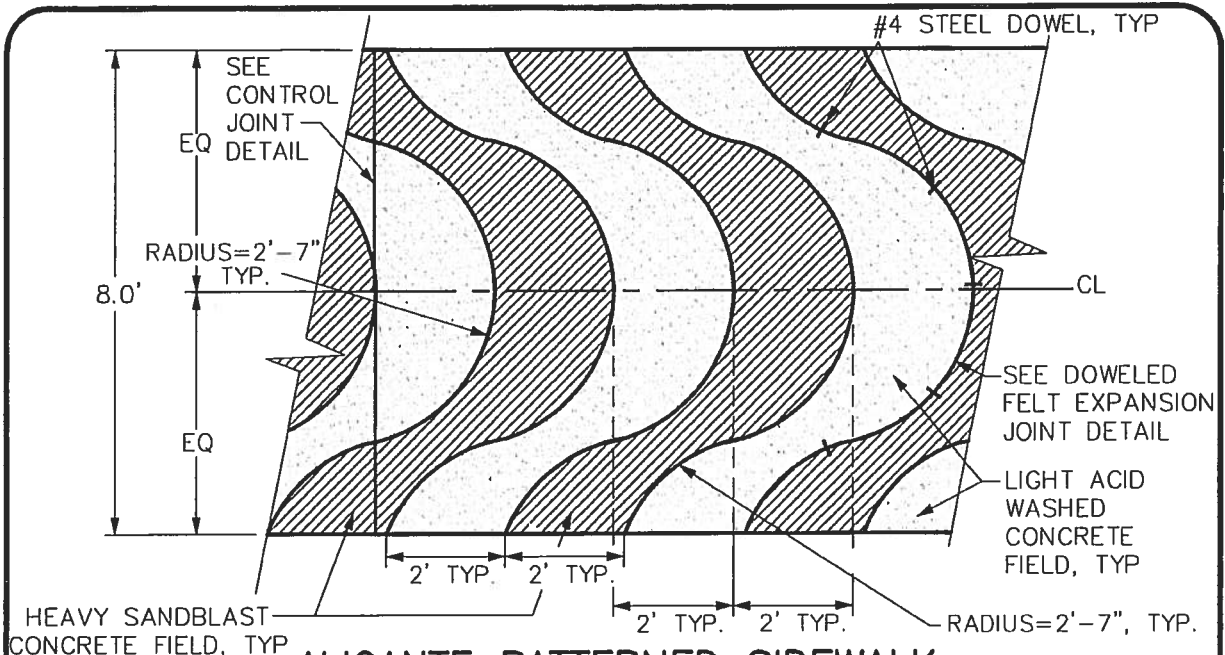

ALICANTE PATTERNED SIDEWALK

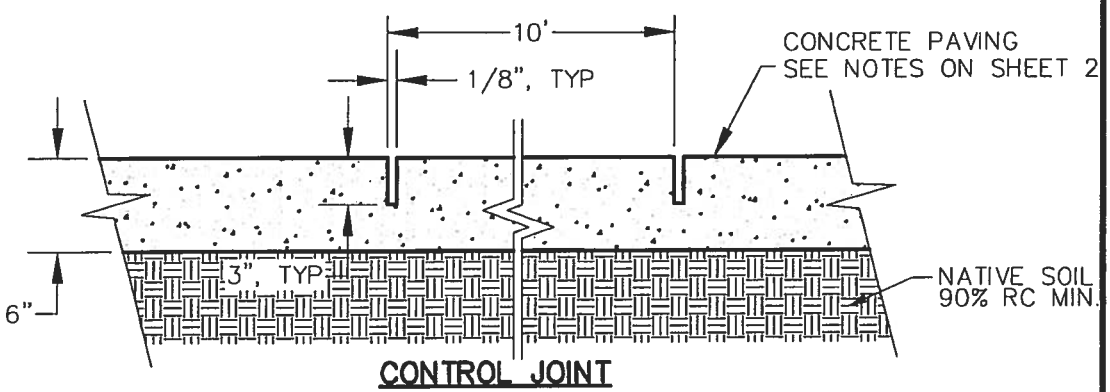
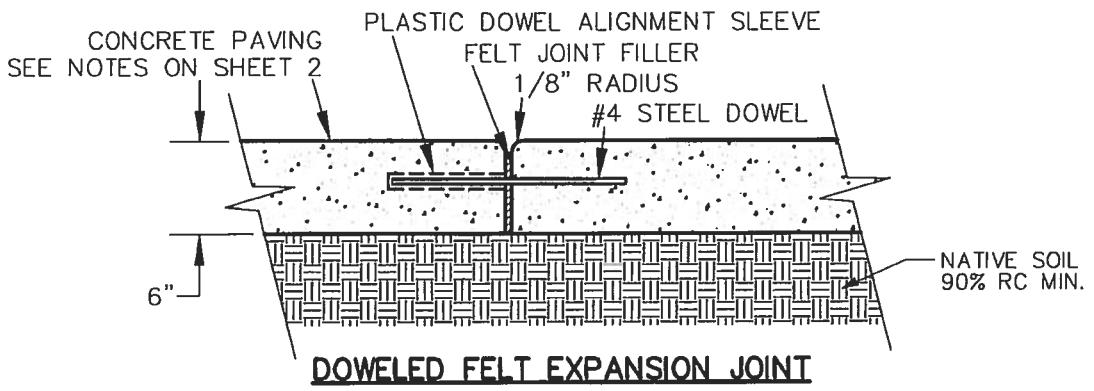

HARBOR BOULEVARD DECORATIVE SIDEWALK IMPROVEMENTS

Approved: *[Signature]* Date: _____

City Engineer R.C.E. 52125 Exp.12-31-16

REVISIONS	BY	DATE

STD. PLAN NUMBER

B-137

SHEET 1 OF 2

ALICANTE PATTERNED SIDEWALK NOTES:

1. A MOCK UP PANEL 8' x 10' SHALL BE COMPLETED BY CONTRACTOR AND APPROVED BY THE ENGINEER PRIOR TO COMMENCEMENT OF WORK.
2. CONCRETE SHALL HAVE DARK GREY INTEGRAL COLOR ACHIEVED BY USING 5LBS OF DAVIS 860 PIGMENT PER SACK OF CEMENT. PIGMENT 8084 IS UNACCEPTABLE.
3. THE 3/8" DIAMETER INYO WHITE AGGREGATE SHALL BE BROADCAST ONTO THE SURFACE OF THE CONCRETE AT A RATE OF 3 TO 4 LBS PER SF AND SHALL BE FLOATED INTO THE SURFACE OF THE CONCRETE AT THE APPROPRIATE TIME. IT CANNOT BE BROADCAST TOO EARLY OR TOO LATE IN THE FINISHING PROCESS.
4. THE CONCRETE SHALL BE FINISHED TO YIELD A SMOOTH (STEEL TROWEL) FINISH SURFACE.
5. THE CONCRETE SHALL BE LIGHT ACID WASHED AFTER AN INITIAL CURING PERIOD OF 2 TO 5 DAYS TO EXPOSE THE AGGREGATE IN THE CONCRETE. THE INYO WHITE AGGREGATE SHALL NOT BE EXPOSED DURING THIS PROCESS.
6. DOWELED FELT EXPANSION JOINT SHALL BE PLACED AT 30' O.C. MAX SPACING AND SHALL BE ALIGNED WITH ALICANTE TEMPLATE EDGE.
7. #4 STEEL DOWEL SHALL BE 18" LONG AT 24" O.C. AND CENTERED ON JOINT.
8. FELT JOINT FILLER SHALL BE PER CITY OF GARDEN GROVE STANDARD SIDEWALK DETAIL B-106.
9. SAWCUT CONTROL JOINTS SHALL BE PLACED IN THE CONCRETE AT 10' O.C., PERPENDICULAR TO THE STREET CENTERLINE, TO A MINIMUM OF 3" DEPTH AS SHOWN IN THE DETAIL ON SHEET 1.
10. TEMPLATE SANDBLAST MATS ARE APPLIED TO THE CONCRETE AFTER A MINIMUM OF ONE WEEK OF CURING. THE CONCRETE SHALL BE SANDBLASTED TO EXPOSE THE INYO WHITE AGGREGATE AND CREATE THE ALICANTE (WAVE) PATTERN.
11. THE CONCRETE SHALL BE CLEANED AFTER SANDBLASTING, AND THEN SEALED WITH PENETRATING SEALER SINAK HLQ-125, OR APPROVED EQUAL.
12. EXISTING "ALICANTE" SIDEWALK CAN BE FOUND ON EITHER SIDE OF HARBOR BOULEVARD BETWEEN LAMPSON AVENUE AND TWINTREE LANE.



City of
Garden Grove
California

**HARBOR BOULEVARD DECORATIVE
SIDEWALK IMPROVEMENTS**

Approved

Date

[Handwritten Signature]

City Engineer R.C.E. 52125 Exp.12-31-16

REVISIONS

BY

DATE



STD. PLAN NUMBER



B-137

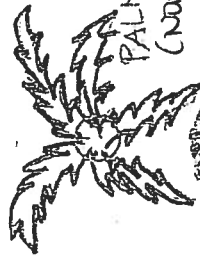

SHEET 2 OF 2

HARBOR BLVD RIGHT-OF-WAY SIDEWALK/LANDSCAPE PLAN

LEGEND:

-  DATE PALM
-  PALM TREE 20' BTH (NOO-FRUIT BEARING)
-  CHINESE FLAMING TREE

-  BIRD OF PARADISE
-  GROUND COVER

-  LIGHT POLE
-  UP LIGHTING FIXTURE

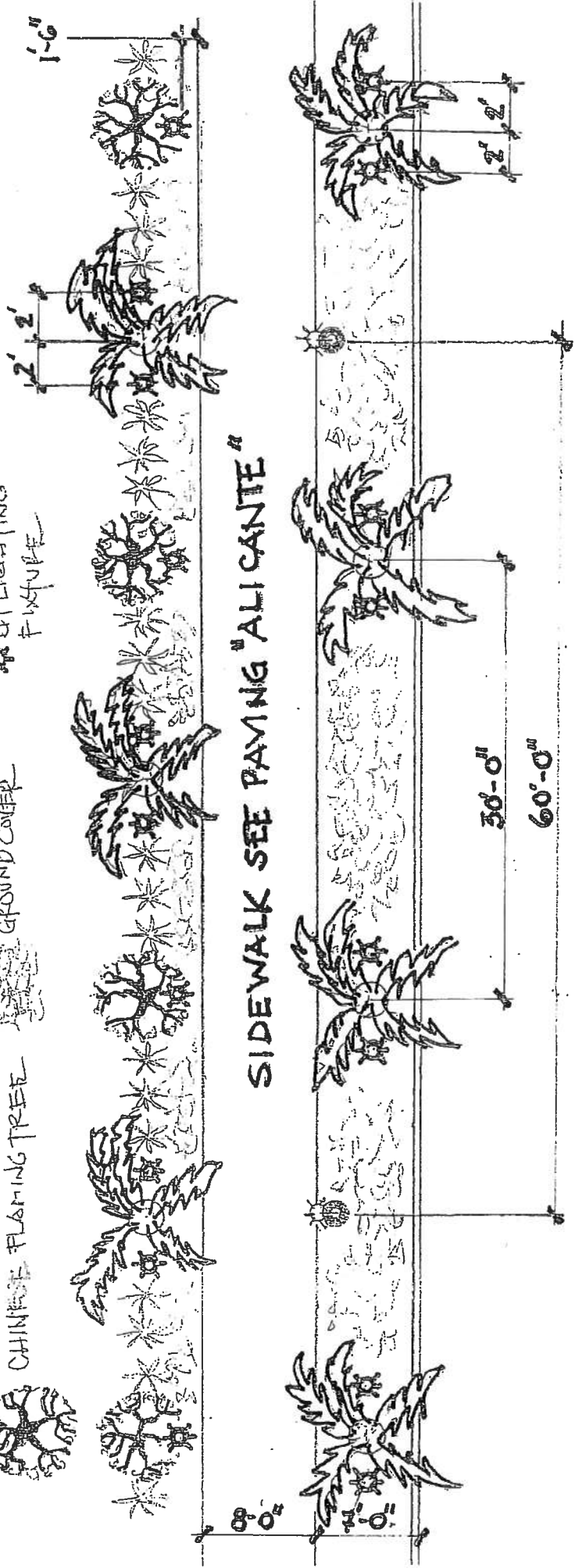

SIDEWALK SEE PAVING "ALICANTE"

EXISTING LANDSCAPE LAYOUT

HARBOR BLVD
GARDEN GROVE

Subject: Re: Site "C" Meeting Update

From: Matthew Reid <matt.reid@landanddesign.com>

Date: Wed, 19 Aug 2015 10:27:53 -0700

To: Maria Parra <mariap@ci.garden-grove.ca.us>

CC: Dave Rose <drose3@charter.net>, Khan Ziad <zkhan@langdonwilson.com>, Karl Hill <karlh@ci.garden-grove.ca.us>, Lee Marino <leem@ci.garden-grove.ca.us>, Greg Blodgett <greg1@ci.garden-grove.ca.us>, Jane Chang <jane.chang@aecom.com>, "Morgan, Jayna" <Jayna.Morgan@aecom.com>

Yes, that will come from our Architect, Ziad Khan.

Matthew Reid

Land & Design, Inc.

3755 Avocado Blvd | #516 | LaMesa, CA 91942

858.735.1858 cell

Skype - [matthew.reid.ca](https://www.skype.com/people/matthew.reid.ca)

matt.reid@landanddesign.com

Check out our new website www.landanddesign.com

On Aug 19, 2015, at 10:25 AM, Maria Parra <mariap@ci.garden-grove.ca.us> wrote:

Matt:

One last item to note, please forward a copy of the Shade and Shadow Study to AECOM and Planning.

Thank you!

Maria Parra

Urban Planner

City of Garden Grove | Planning Services Division

11222 Acacia Parkway, Garden Grove, CA 92840

(714) 741-5312 | (714) 741-5578 fax

mariap@ci.garden-grove.ca.us | www.ci.garden-grove.ca.us

Community Development Department of the City of Garden Grove

"Providing Quality Services Through Creativity and Collaboration"

City Hall Hours:

Monday-Thursday: 7:30 a.m. to 5:30 p.m.

First Friday of the Month: 7:30 a.m. to 5:00 p.m.

Direct Website Links:

[Planning Division](#)

Municipal Code, Title 9, Land Use
Zoning Map

From: "Maria Parra" <mariap@ci.garden-grove.ca.us>
To: "Matthew Reid" <matt.reid@landanddesign.com>, "Dave Rose" <drose3@charter.net>, zkhan@langdonwilson.com, "Karl Hill" <karlh@ci.garden-grove.ca.us>, "Lee Marino" <leem@ci.garden-grove.ca.us>, "Greg Blodgett" <greg1@ci.garden-grove.ca.us>, "jayan morgan" <jayan.morgan@aecom.com>, "Jane Chang" <jane.chang@aecom.com>
Sent: Wednesday, August 19, 2015 10:10:40 AM
Subject: Site "C" Meeting Update

All:

Below is a summary of the items necessary to proceed with the CEQA addendum and the Site Plan review.

L&D to:

- Submit to Planning and AECOM a revised project summary per Table 1 of the Mitigated Negative Declaration (see attached MND Table 1 Project Summary).
- Submit a revised, detailed site plan, and building sections to Planning and AECOM. Planning will review the plans with Fire, Building, and Engineering. The plans must also include the proposed building LED sign location(s), dimensions, and square footage. Planning staff will review and discuss the proposed LED signs internally with the policymakers.
- The proposed LED signs will require a light and glare study that will be submitted to AECOM. The LED signs will require an amendment to the PUD.
- To provide a project schedule timeline

I have attached a copy of the Harbor Blvd sidewalk standard and landscaping, and a copy of the Tentative Parcel Map.

Best regards,

Maria Parra

Urban Planner
City of Garden Grove | Planning Services Division
11222 Acacia Parkway, Garden Grove, CA 92840
(714) 741-5312 | (714) 741-5578 fax
mariap@ci.garden-grove.ca.us | www.ci.garden-grove.ca.us

Community Development Department of the City of Garden Grove
"Providing Quality Services Through Creativity and Collaboration"

City Hall Hours:

Monday-Thursday: 7:30 a.m. to 5:30 p.m.

First Friday of the Month: 7:30 a.m. to 5:00 p.m.

Direct Website Links:

Planning Division

Municipal Code, Title 9, Land Use

Zoning Map

Re:

Subject: Re:

From: Greg Blodgett <greg1@ci.garden-grove.ca.us>

Date: Wed, 19 Aug 2015 19:12:01 -0700 (PDT)

To: Matthew Reid <matt.reid@landanddesign.com>

CC: Greg Blodgett <greg1@ci.garden-grove.ca.us>

Ok will resend in an

Sent from my iPhone

On Aug 19, 2015, at 6:59 PM, Matthew Reid <matt.reid@landanddesign.com> wrote:

No haven't received anything regarding schedule from the City.

Matthew Reid

Land & Design, Inc.

3755 Avocado Blvd | #516 | LaMesa, CA 91942

858.735.1858 cell

Skype - [matthew.reid.ca](https://www.skype.com/user/matthew.reid.ca)

matt.reid@landanddesign.com

Check out our new website www.landanddesign.com

On Aug 19, 2015, at 6:53 PM, Greg Blodgett <greg1@ci.garden-grove.ca.us> wrote:

Will need to resend tomorrow this is the revised tolling schedule

Did we send this to you before

Sent from my iPhone

On Aug 19, 2015, at 6:20 PM, Matthew Reid <matt.reid@landanddesign.com> wrote:

Says the file is corrupt.....send again.

Matthew Reid

Land & Design, Inc.

3755 Avocado Blvd | #516 | LaMesa, CA 91942

858.735.1858 cell

Skype - [matthew.reid.ca](https://www.skype.com/user/matthew.reid.ca)

matt.reid@landanddesign.com

Check out our new website www.landanddesign.com

Re:

On Aug 19, 2015, at 6:19 PM, Greg Blodgett <greg1@ci.garden-grove.ca.us> wrote:

Sent from my iPhone

Begin forwarded message:

From: Greg Blodgett <greg1@ci.garden-grove.ca.us>

To: Tom Clark <tclark@sycr.com>

Site C presentation for next tuesday night

Greg Blodgett

SR Project Manager

City of Garden Grove

Economic Development

<A City Council Meeting 2015; Resort Development Agreement Land & Design Inc.ppt>

Subject: 20150819162052609.pdf
From: Greg Blodgett <greg1@ci.garden-grove.ca.us>
Date: Fri, 21 Aug 2015 08:01:20 -0700 (PDT)
To: Matthew Reid <matt.reid@landanddesign.com>

Revised schedule base on tolling site control

Can you send us a letter stating you are ok with the
New schedule

Sent from my iPhone

20150819162052609.pdf	Content-Type: application/pdf Content-Encoding: base64
------------------------------	---

Part 1.3

Part 1.3	Content-Type: text/plain Content-Encoding: 7bit
-----------------	--

EXHIBIT D

SCHEDULE OF PERFORMANCE – CONDENSED SCHEDULE

PERFORMANCE ITEM	DATE
1. City and Developer execute RHIDA.	On or before April 15, 2013.
2. City and Developer open Escrow.	Within thirty (30) days after Date of Agreement.
3. City accepts conveyance of fee title to all Agency Property.	On or before September 1, 2013. <i>(May 29, 2015)</i>
4. Developer completes its Site Investigation pursuant to Section 204.	On or before the Due Diligence Date. <i>(August 27, 2015 → May 29 + 90 Days)</i>
5. Developer notifies City of election of whether to include Third Party Property in Project and add to Site and, if applicable, provides City with evidence of acquisition of necessary interest in Third Party Property.	On or before January 1, 2014. <i>(September 29, 2015)</i>
6. Developer submits completed application for tentative Subdivision Map, Development Agreement, and other necessary or desired Land Use Approvals.	On or before January 1, 2014. <i>(September 29, 2015)</i>
7. City approves, conditionally approves or rejects tentative Subdivision Map, Development Agreement, and other necessary or desired discretionary Additional Land Use Approvals.	On or before May 1, 2014. <i>(January 27, 2016)</i>
8. City and Developer agree in writing which Hotels constitute Upper Upscale Hotel(s) and Additional Hotel(s), respectively.	On or before October 1, 2014. <i>(June 28, 2016)</i>
9. Developer submits and obtains City approval of the identity of the Hotel Operators, Franchisors, and Franchise Agreements and Developer executes the approved Franchise Agreements.	On or before October 1, 2014. <i>(June 28, 2016)</i>

If the City has not acquired fee title to all of the Agency Property by such date, then each subsequent date set forth in this Schedule of Performance will be extended on a day-for-day basis for each day after September 1, 2013 through and including the date upon which City acquires fee title to all of the Agency Property.

EXHIBIT D

PERFORMANCE ITEM	DATE
10. Developer submits and obtains City approval of Construction Drawings.	On or before February 1, 2015. <i>(October 30, 2016)</i>
11. Developer obtains necessary commitments for issuance of building permits and other similar required non-discretionary Land Use Approvals.	On or before March 1, 2015. <i>(November 27, 2016)</i>
12. Developer provides evidence of financing.	On or before May 15, 2015. <i>(February 10, 2017)</i>
13. City completes demolition, Site clearance and remediation, if applicable, pursuant to Paragraph II.1. of the Scope of Development	On or before August 15, 2015. <i>(May 13, 2017)</i>
14. Developer and City Close Escrow and Developer commences grading.	On or before September 1, 2015. ¹ <i>(May 30, 2017)</i>
15. Construction Commencement Date.	On or before September 1, 2015. <i>(May 30, 2017)</i>
16. Offsite Infrastructure Completed by City	Concurrently with completion of the Developer Improvements.
17. Developer Completes Construction of the Developer Improvements	Within twenty six (26) months after Close of Escrow. <i>(July 30, 2019)</i>

¹ Although the outside date for the Closing of September 1, 2015, may not be extended for the events described in Section 602, the Closing may be extended until March 1, 2016 provided that, as of September 1, 2015, the Franchise Agreement for the Upper Upscale Hotel is still operative and neither the Developer nor the Franchisor is in breach or default thereunder. The Closing may also be extended until September 1, 2016 if on March 1, 2016, the Franchise Agreement for the Upper Upscale Hotel is still operative and neither the Developer nor Franchisor is in breach or default thereunder.

Subject: Re: 20150819162052609.pdf
From: Greg Blodgett <greg1@ci.garden-grove.ca.us>
Date: Fri, 21 Aug 2015 10:11:15 -0700 (PDT)
To: Matthew Reid <matt.reid@landanddesign.com>

Great

Do you think you can send a letter approving/agreeing to the new schedule prior to our agency meeting next Tuesday night.

Sent from my iPhone

On Aug 21, 2015, at 8:26 AM, Matthew Reid <matt.reid@landanddesign.com> wrote:

Since this is the 1st notice we've received of City having Fee interest in Agency property, Let me review and get back to you.

Matthew Reid

Land & Design, Inc.
3755 Avocado Blvd | #516 | LaMesa, CA 91942
858.735.1858 cell
Skype - [matthew.reid.ca](https://www.skype.com/user/matthew.reid.ca)
matt.reid@landanddesign.com

Check out our new website www.landanddesign.com

On Aug 21, 2015, at 8:01 AM, Greg Blodgett <greg1@ci.garden-grove.ca.us> wrote:

Revised schedule base on tolling site control

Can you send us a letter stating you are ok with the
New schedule
<20150819162052609.pdf>

Sent from my iPhone

Subject: Joe's Italian Ice

From: Matthew Reid <matt.reid@landanddesign.com>

Date: Thu, 27 Aug 2015 09:20:00 -0700

To: Greg Blodgett <Greg1@ci.garden-grove.ca.us>

CC: Dave Rose <drose3@charter.net>, Scott Stiles <sstiles@ci.garden-grove.ca.us>

Greg,

Per our conversation, we are scheduling to break ground in Q2 of next year. Therefore, in my opinion, in order for that to occur, the city will need time to demolish all the buildings, clear the site and have utilities out of the way prior to us breaking ground. Based on this schedule, in my opinion, there is not time for Joes Italian Ice to continue business operations at this location. As I understand the situation, the City has already paid him to relocate correct?

Any additional time he is allowed to be on the property will cause delays in the opening of our project.

Please advise the schedule to having the property cleared including utilities...

Thank you

Matthew Reid

Land & Design, Inc.

3755 Avocado Blvd | #516 | LaMesa, CA 91942

858.735.1858 cell

Skype - [matthew.reid.ca](https://www.skype.com/user/matthew.reid.ca)

matt.reid@landanddesign.com

Check out our new website www.landanddesign.com

Subject: Re: Joes Italian Ice - Mike Abeyta
From: Greg Blodgett <greg1@ci.garden-grove.ca.us>
Date: Thu, 10 Sep 2015 11:29:14 -0700 (PDT)
To: Carlos Marquez <carlosma@ci.garden-grove.ca.us>
CC: Matthew Reid <matt.reid@landanddesign.com>

Great job will forward progress to matt Reid

Sent from my iPhone

On Sep 10, 2015, at 10:47 AM, Carlos Marquez <carlosma@ci.garden-grove.ca.us> wrote:

The saga is over; possession is with the City. The property maintenance contractor will be boarding up the property. The temporary fencing will go up tomorrow .

Many thanks to Earl Wallace (outside counsel) for his success in obtaining the judgement in the City's favor.

Carlos

<FullSizeRender.jpg>

Sent from my iPhone

Subject: Re: Site "C" Meeting Update
From: David Rose <drose3@charter.net>
Date: Tue, 15 Sep 2015 20:28:54 -0700
To: Greg Blodgett <greg1@ci.garden-grove.ca.us>
CC: David Rose <drose3@hotmail.com>, Matt Reid <matt.reid@landanddesign.com>

We need to have Ziad in attendance and if you guys are off on Friday, how about a day next week?

Please advise.

Thanks.

Dave

Sent from my iPad

Please forgive any errors.

On Sep 15, 2015, at 8:24 PM, Greg Blodgett <greg1@ci.garden-grove.ca.us> wrote:

We are off Friday

Thurs we did have project meeting standing time in afternoon

Our cm scott stiles also wanted to attend

Sent from my iPhone

On Sep 15, 2015, at 6:29 PM, David Rose <drose3@charter.net> wrote:

Maria:

I hope this email finds you doing well.

We're ready for our official meeting with the City to present our updates to PUD, etc., for Site "C".

As such, we'd like to set up a meeting with the City and AECOM either for this Friday and/or early next week.

Please advise.

Thanks.

Dave

Sent from my iPhone

Please forgive any errors. 😊

On Aug 19, 2015, at 10:25 AM, Maria Parra <mariap@ci.garden-grove.ca.us> wrote:

Matt:

One last item to note, please forward a copy of the Shade and Shadow Study to AECOM and Planning.

Thank you!

Maria Parra

Urban Planner

City of Garden Grove | Planning Services Division

11222 Acacia Parkway, Garden Grove, CA 92840

(714) 741-5312 | (714) 741-5578 fax

mariap@ci.garden-grove.ca.us | www.ci.garden-grove.ca.us

Community Development Department of the City of Garden Grove

"Providing Quality Services Through Creativity and Collaboration"

City Hall Hours:

Monday-Thursday: 7:30 a.m. to 5:30 p.m.

First Friday of the Month: 7:30 a.m. to 5:00 p.m.

Direct Website Links:

[Planning Division](#)

[Municipal Code, Title 9, Land Use](#)

[Zoning Map](#)

From: "Maria Parra" <mariap@ci.garden-grove.ca.us>

To: "Matthew Reid" <matt.reid@landanddesign.com>, "Dave Rose" <drose3@charter.net>, zkhan@langdonwilson.com, "Karl Hill" <karlh@ci.garden-grove.ca.us>, "Lee Marino" <leem@ci.garden-grove.ca.us>, "Greg Blodgett" <greg1@ci.garden-grove.ca.us>, "jayan morgan" <jayan.morgan@aecom.com>, "Jane Chang" <jane.chang@aecom.com>

Sent: Wednesday, August 19, 2015 10:10:40 AM

Subject: Site "C" Meeting Update

All:

Below is a summary of the items necessary to proceed with the CEQA addendum and the Site Plan review.

L&D to:

- Submit to Planning and AECOM a revised project summary per Table 1 of the Mitigated Negative Declaration (see attached MND Table 1 Project Summary).

- Submit a revised, detailed site plan, and building sections to Planning and AECOM. Planning will review the plans with Fire, Building, and Engineering. The plans must also include the proposed building LED sign location(s), dimensions, and square footage. Planning staff will review and discuss the proposed LED signs internally with the policymakers.
- The proposed LED signs will require a light and glare study that will be submitted to AECOM. The LED signs will require an amendment to the PUD.
- To provide a project schedule timeline

I have attached a copy of the Harbor Blvd sidewalk standard and landscaping, and a copy of the Tentative Parcel Map.

Best regards,

Maria Parra

Urban Planner
City of Garden Grove | Planning Services Division
11222 Acacia Parkway, Garden Grove, CA 92840
(714) 741-5312 | (714) 741-5578 fax
mariap@ci.garden-grove.ca.us | www.ci.garden-grove.ca.us

Community Development Department of the City of Garden Grove
"Providing Quality Services Through Creativity and Collaboration"

City Hall Hours:
Monday-Thursday: 7:30 a.m. to 5:30 p.m.
First Friday of the Month: 7:30 a.m. to 5:00 p.m.

Direct Website Links:
[Planning Division](#)
[Municipal Code, Title 9, Land Use](#)
[Zoning Map](#)

Subject: Re: Site "C" Meeting Update
From: Greg Blodgett <greg1@ci.garden-grove.ca.us>
Date: Tue, 15 Sep 2015 20:34:26 -0700 (PDT)
To: David Rose <drose3@charter.net>

We have council tues so we may be preparing mom and tues so wends day Thursday are better next week

Sent from my iPhone

On Sep 15, 2015, at 8:29 PM, David Rose <drose3@charter.net> wrote:

We need to have Ziad in attendance and if you guys are off on Friday, how about a day next week?
Please advise.

Thanks.

Dave

Sent from my iPad

Please forgive any errors.

On Sep 15, 2015, at 8:24 PM, Greg Blodgett <greg1@ci.garden-grove.ca.us> wrote:

We are off Friday

Thurs we did have project meeting standing time in afternoon

Our cm scott stiles also wanted to attend

Sent from my iPhone

On Sep 15, 2015, at 6:29 PM, David Rose <drose3@charter.net> wrote:

Maria:

I hope this email finds you doing well.

We're ready for our official meeting with the City to present our updates to PUD, etc., for Site "C".

As such, we'd like to set up a meeting with the City and AECOM either for this Friday and/or early next week.

Please advise.

Thanks.

Dave

Sent from my iPhone

Please forgive any errors. 😊

On Aug 19, 2015, at 10:25 AM, Maria Parra <mariap@ci.garden-grove.ca.us> wrote:

Matt:

One last item to note, please forward a copy of the Shade and Shadow Study to AECOM and Planning.

Thank you!

Maria Parra

Urban Planner

City of Garden Grove | Planning Services Division

11222 Acacia Parkway, Garden Grove, CA 92840

(714) 741-5312 | (714) 741-5578 fax

mariap@ci.garden-grove.ca.us | www.ci.garden-grove.ca.us

Community Development Department of the City of Garden Grove

"Providing Quality Services Through Creativity and Collaboration"

City Hall Hours:

Monday-Thursday: 7:30 a.m. to 5:30 p.m.

First Friday of the Month: 7:30 a.m. to 5:00 p.m.

Direct Website Links:

[Planning Division](#)

[Municipal Code, Title 9, Land Use](#)

[Zoning Map](#)

From: "Maria Parra" <mariap@ci.garden-grove.ca.us>

To: "Matthew Reid" <matt.reid@landanddesign.com>, "Dave Rose" <drose3@charter.net>, zkhan@langdonwilson.com, "Karl Hill" <karlh@ci.garden-grove.ca.us>, "Lee Marino" <leem@ci.garden-grove.ca.us>, "Greg Blodgett" <greg1@ci.garden-grove.ca.us>, "jayan morgan" <jayan.morgan@aecom.com>, "Jane Chang" <jane.chang@aecom.com>

Sent: Wednesday, August 19, 2015 10:10:40 AM

Subject: Site "C" Meeting Update

All:

Below is a summary of the items necessary to proceed with the CEQA addendum and the Site

Plan review.

L&D to:

- Submit to Planning and AECOM a revised project summary per Table 1 of the Mitigated Negative Declaration (see attached MND Table 1 Project Summary).
- Submit a revised, detailed site plan, and building sections to Planning and AECOM. Planning will review the plans with Fire, Building, and Engineering. The plans must also include the proposed building LED sign location(s), dimensions, and square footage. Planning staff will review and discuss the proposed LED signs internally with the policymakers.
- The proposed LED signs will require a light and glare study that will be submitted to AECOM. The LED signs will require an amendment to the PUD.
- To provide a project schedule timeline

I have attached a copy of the Harbor Blvd sidewalk standard and landscaping, and a copy of the Tentative Parcel Map.

Best regards,

Maria Parra

Urban Planner

City of Garden Grove | Planning Services Division

11222 Acacia Parkway, Garden Grove, CA 92840

(714) 741-5312 | (714) 741-5578 fax

mariap@ci.garden-grove.ca.us | www.ci.garden-grove.ca.us

Community Development Department of the City of Garden Grove

"Providing Quality Services Through Creativity and Collaboration"

City Hall Hours:

Monday-Thursday: 7:30 a.m. to 5:30 p.m.

First Friday of the Month: 7:30 a.m. to 5:00 p.m.

Direct Website Links:

[Planning Division](#)

[Municipal Code, Title 9, Land Use](#)

[Zoning Map](#)

Subject: Re: Site "C" Meeting Update
From: David Rose <drose3@charter.net>
Date: Tue, 15 Sep 2015 20:41:29 -0700
To: Greg Blodgett <greg1@ci.garden-grove.ca.us>
CC: Matt Reid <matt.reid@landanddesign.com>, David Rose <drose3@hotmail.com>, Ziad Khan <zkhan@langdonwilson.com>

I'm available on both Wednesday and/or Thursday, but I need to check with both Matt and Ziad.

Can you please confirm with City Staff and AECOM?

Please advise.

Thanks.

Dave

Sent from my iPad

Please forgive any errors.

On Sep 15, 2015, at 8:34 PM, Greg Blodgett <greg1@ci.garden-grove.ca.us> wrote:

We have council tues so we may be preparing mom and tues so wends day Thursday are better next week

Sent from my iPhone

On Sep 15, 2015, at 8:29 PM, David Rose <drose3@charter.net> wrote:

We need to have Ziad in attendance and if you guys are off on Friday, how about a day next week?

Please advise.

Thanks.

Dave

Sent from my iPad

Please forgive any errors.

On Sep 15, 2015, at 8:24 PM, Greg Blodgett <greg1@ci.garden-grove.ca.us> wrote:

We are off Friday

Thurs we did have project meeting standing time in afternoon

Our cm scott stiles also wanted to attend

Sent from my iPhone

On Sep 15, 2015, at 6:29 PM, David Rose <drose3@charter.net> wrote:

Maria:

I hope this email finds you doing well.

We're ready for our official meeting with the City to present our updates to PUD, etc., for Site "C".

As such, we'd like to set up a meeting with the City and AECOM either for this Friday and/or early next week.

Please advise.

Thanks.

Dave

Sent from my iPhone

Please forgive any errors. 😊

On Aug 19, 2015, at 10:25 AM, Maria Parra <mariap@ci.garden-grove.ca.us> wrote:

Matt:

One last item to note, please forward a copy of the Shade and Shadow Study to AECOM and Planning.

Thank you!

Maria Parra

Urban Planner

City of Garden Grove | Planning Services Division

11222 Acacia Parkway, Garden Grove, CA 92840

(714) 741-5312 | (714) 741-5578 fax

mariap@ci.garden-grove.ca.us | www.ci.garden-grove.ca.us

Community Development Department of the City of Garden Grove

"Providing Quality Services Through Creativity and Collaboration"

City Hall Hours:

Monday-Thursday: 7:30 a.m. to 5:30 p.m.

First Friday of the Month: 7:30 a.m. to 5:00 p.m.

Direct Website Links:

[Planning Division](#)

[Municipal Code, Title 9, Land Use](#)

Zoning Map

From: "Maria Parra" <mariap@ci.garden-grove.ca.us>
To: "Matthew Reid" <matt.reid@landanddesign.com>, "Dave Rose" <drose3@charter.net>, zkhan@langdonwilson.com, "Karl Hill" <karlh@ci.garden-grove.ca.us>, "Lee Marino" <leem@ci.garden-grove.ca.us>, "Greg Blodgett" <greg1@ci.garden-grove.ca.us>, "jayan morgan" <jayan.morgan@aecom.com>, "Jane Chang" <jane.chang@aecom.com>
Sent: Wednesday, August 19, 2015 10:10:40 AM
Subject: Site "C" Meeting Update

All:

Below is a summary of the items necessary to proceed with the CEQA addendum and the Site Plan review.

L&D to:

- Submit to Planning and AECOM a revised project summary per Table 1 of the Mitigated Negative Declaration (see attached MND Table 1 Project Summary).
- Submit a revised, detailed site plan, and building sections to Planning and AECOM. Planning will review the plans with Fire, Building, and Engineering. The plans must also include the proposed building LED sign location(s), dimensions, and square footage. Planning staff will review and discuss the proposed LED signs internally with the policymakers.
- The proposed LED signs will require a light and glare study that will be submitted to AECOM. The LED signs will require an amendment to the PUD.
- To provide a project schedule timeline

I have attached a copy of the Harbor Blvd sidewalk standard and landscaping, and a copy of the Tentative Parcel Map.

Best regards,

Maria Parra

Urban Planner
City of Garden Grove | Planning Services Division
11222 Acacia Parkway, Garden Grove, CA 92840
(714) 741-5312 | (714) 741-5578 fax
mariap@ci.garden-grove.ca.us | www.ci.garden-grove.ca.us

Community Development Department of the City of Garden Grove
"Providing Quality Services Through Creativity and Collaboration"

City Hall Hours:

Monday-Thursday: 7:30 a.m. to 5:30 p.m.

First Friday of the Month: 7:30 a.m. to 5:00 p.m.

Direct Website Links:

Planning Division

Municipal Code, Title 9, Land Use

Zoning Map

Subject: Re: Site "C" Meeting Update
From: Greg Blodgett <greg1@ci.garden-grove.ca.us>
Date: Tue, 15 Sep 2015 21:09:45 -0700 (PDT)
To: David Rose <drose3@charter.net>

Ok

Sent from my iPhone

On Sep 15, 2015, at 8:41 PM, David Rose <drose3@charter.net> wrote:

I'm available on both Wednesday and/or Thursday, but I need to check with both Matt and Ziad.

Can you please confirm with City Staff and AECOM?

Please advise.

Thanks.

Dave

Sent from my iPad

Please forgive any errors.

On Sep 15, 2015, at 8:34 PM, Greg Blodgett <greg1@ci.garden-grove.ca.us> wrote:

We have council tues so we may be preparing mom and tues so wends day Thursday are better next week

Sent from my iPhone

On Sep 15, 2015, at 8:29 PM, David Rose <drose3@charter.net> wrote:

We need to have Ziad in attendance and if you guys are off on Friday, how about a day next week?

Please advise.

Thanks.

Dave

Sent from my iPad

Please forgive any errors.

On Sep 15, 2015, at 8:24 PM, Greg Blodgett <greg1@ci.garden-grove.ca.us> wrote:

We are off Friday

Thurs we did have project meeting standing time in afternoon

Our cm scott stiles also wanted to attend

Sent from my iPhone

On Sep 15, 2015, at 6:29 PM, David Rose <drose3@charter.net> wrote:

Maria:

I hope this email finds you doing well.

We're ready for our official meeting with the City to present our updates to PUD, etc., for Site "C".

As such, we'd like to set up a meeting with the City and AECOM either for this Friday and/or early next week.

Please advise.

Thanks.

Dave

Sent from my iPhone

Please forgive any errors. 😊

On Aug 19, 2015, at 10:25 AM, Maria Parra <mariap@ci.garden-grove.ca.us> wrote:

Matt:

One last item to note, please forward a copy of the Shade and Shadow Study to AECOM and Planning.

Thank you!

Maria Parra

Urban Planner

City of Garden Grove | Planning Services Division

11222 Acacia Parkway, Garden Grove, CA 92840

(714) 741-5312 | (714) 741-5578 fax

mariap@ci.garden-grove.ca.us | www.ci.garden-grove.ca.us

Community Development Department of the City of Garden Grove

"Providing Quality Services Through Creativity and Collaboration"

City Hall Hours:

Monday-Thursday: 7:30 a.m. to 5:30 p.m.

First Friday of the Month: 7:30 a.m. to 5:00 p.m.

Direct Website Links:

[Planning Division](#)

[Municipal Code, Title 9, Land Use](#)

[Zoning Map](#)

From: "Maria Parra" <mariap@ci.garden-grove.ca.us>
To: "Matthew Reid" <matt.reid@landanddesign.com>, "Dave Rose" <drose3@charter.net>, zkhan@langdonwilson.com, "Karl Hill" <karlh@ci.garden-grove.ca.us>, "Lee Marino" <leem@ci.garden-grove.ca.us>, "Greg Blodgett" <greg1@ci.garden-grove.ca.us>, "jayan morgan" <jayan.morgan@aecom.com>, "Jane Chang" <jane.chang@aecom.com>
Sent: Wednesday, August 19, 2015 10:10:40 AM
Subject: Site "C" Meeting Update

All:

Below is a summary of the items necessary to proceed with the CEQA addendum and the Site Plan review.

L&D to:

- Submit to Planning and AECOM a revised project summary per Table 1 of the Mitigated Negative Declaration (see attached MND Table 1 Project Summary).
- Submit a revised, detailed site plan, and building sections to Planning and AECOM. Planning will review the plans with Fire, Building, and Engineering. The plans must also include the proposed building LED sign location(s), dimensions, and square footage. Planning staff will review and discuss the proposed LED signs internally with the policymakers.
- The proposed LED signs will require a light and glare study that will be submitted to AECOM. The LED signs will require an amendment to the PUD.
- To provide a project schedule timeline

I have attached a copy of the Harbor Blvd sidewalk standard and landscaping, and a copy of the Tentative Parcel Map.

Best regards,

Maria Parra

Urban Planner

City of Garden Grove | Planning Services Division

11222 Acacia Parkway, Garden Grove, CA 92840

(714) 741-5312 | (714) 741-5578 fax

mariap@ci.garden-grove.ca.us | www.ci.garden-grove.ca.us

Community Development Department of the City of Garden Grove
"Providing Quality Services Through Creativity and Collaboration"

City Hall Hours:

Monday-Thursday: 7:30 a.m. to 5:30 p.m.

First Friday of the Month: 7:30 a.m. to 5:00 p.m.

Direct Website Links:

Planning Division

Municipal Code, Title 9, Land Use

Zoning Map

Re: Site "C" City Meeting

Subject: Re: Site "C" City Meeting

From: David Rose <drose3@charter.net>

Date: Tue, 15 Sep 2015 23:35:38 -0700

To: Greg Blodgett <greg1@ci.garden-grove.ca.us>

CC: David Rose <drose3@hotmail.com>, Matt Reid <matt.reid@landanddesign.com>

Ok, can you confirm with Maria and AECOM, and I'll do the same with Matt and Ziad.

Dave

Sent from my iPhone

Please forgive any errors. 😊

On Sep 15, 2015, at 11:05 PM, Greg Blodgett <greg1@ci.garden-grove.ca.us> wrote:

Late Wednesday day or 11 on tues work best for Scott

Sent from my iPhone

Subject: Re: Site "C" City Meeting
From: Matthew Reid <Matt.reid@landanddesign.com>
Date: Wed, 16 Sep 2015 06:56:31 -0700
To: David Rose <drose3@charter.net>
CC: Greg Blodgett <greg1@ci.garden-grove.ca.us>, David Rose <drose3@hotmail.com>

Either work for me

Sent from my iPhone
Matthew Reid
Land & Design, Inc.
3755 Avocado Blvd | #516 | LaMesa, CA 91942
858.735.1858 cell
Skype - matthew.reid.ca
matt.reid@landanddesign.com

Check out our new website www.landanddesign.com

On Sep 15, 2015, at 11:35 PM, David Rose <drose3@charter.net> wrote:

Ok, can you confirm with Maria and AECOM, and I'll do the same with Matt and Ziad.

Dave

Sent from my iPhone

Please forgive any errors. 😊

On Sep 15, 2015, at 11:05 PM, Greg Blodgett <greg1@ci.garden-grove.ca.us> wrote:

Late Wednesday day or 11 on tues work best for Scott

Sent from my iPhone

Re: Site "C" City Meeting

Subject: Re: Site "C" City Meeting
From: Greg Blodgett <greg1@ci.garden-grove.ca.us>
Date: Wed, 16 Sep 2015 08:41:56 -0700 (PDT)

----- Original Message -----

From: "Matthew Reid" <Matt.reid@landanddesign.com>
To: "David Rose" <drose3@charter.net>
Cc: "Greg Blodgett" <greg1@ci.garden-grove.ca.us>, "David Rose" <drose3@hotmail.com>
Sent: Wednesday, September 16, 2015 6:56:31 AM
Subject: Re: Site "C" City Meeting

Either work for me

Sent from my iPhone

Matthew Reid
Land & Design, Inc.
3755 Avocado Blvd | #516 | LaMesa, CA 91942
858.735.1858 cell
Skype - matthew.reid.ca
matt.reid@landanddesign.com

Check out our new website www.landanddesign.com

On Sep 15, 2015, at 11:35 PM, David Rose <drose3@charter.net> wrote:

Ok, can you confirm with Maria and AECOM, and I'll do the same with Matt and Ziad.

Dave

Sent from my iPhone

Please forgive any errors. 😊

On Sep 15, 2015, at 11:05 PM, Greg Blodgett <greg1@ci.garden-grove.ca.us> wrote:

Late Wednesday day or 11 on tues work best for Scott

Sent from my iPhone

Re: Matt Reid Hard Rock

Subject: Re: Matt Reid Hard Rock
From: Greg Blodgett <greg1@ci.garden-grove.ca.us>
Date: Wed, 16 Sep 2015 14:16:04 -0700 (PDT)
To: Matthew Reid <matt.reid@landanddesign.com>

Ok

can you put together an agenda

----- Original Message -----

From: "Matthew Reid" <matt.reid@landanddesign.com>
To: "Scott Stiles" <sstiles@ci.garden-grove.ca.us>, "Karl Hill" <karlh@ci.garden-grove.ca.us>, "Kingsley Okereke" <kingsley@ci.garden-grove.ca.us>, "Khan Ziad" <zkhan@langdonwilson.com>, "Dave Rose" <drose3@charter.net>, "Greg Blodgett" <greg1@ci.garden-grove.ca.us>, "Grace Lee" <gracel@ci.garden-grove.ca.us>
Sent: Wednesday, September 16, 2015 1:37:38 PM
Subject: Matt Reid Hard Rock

Please invite AECOM. Also, please delete any reference to the flag as this is to remain confidential.
thanks

Matt Reid Hard Rock

Scheduled: Sep 22, 2015, 3:00 PM to 4:00 PM

Location: CMCR

Invitees: Scott Stiles, Karl Hill, Kingsley Okereke, ziad kahn, drose3, Greg Blodgett, Matthew Reid, Grace Lee

The following is a new meeting request:

Subject: Matt Reid Hard Rock

Organizer: "Greg Blodgett" <greg1@ci.garden-grove.ca.us >

Location: CMCR

Time: Tuesday, September 22, 2015, 3:00:00 PM - 4:00:00 PM GMT -08:00 US/Canada Pacific

Re: Matt Reid Hard Rock

Invitees: drose3@charter.net ; karlh@ci.garden-grove.ca.us ; kingsley@ci.garden-grove.ca.us ; sstiles@ci.garden-grove.ca.us ; gracel@ci.garden-grove.ca.us ; matt.reid@landanddesign.com ; drose3@charter.net ; zkhan@langdonwilson.com

~~*~*~*~*~*~*~*~*

Matthew Reid
Land & Design, Inc.
3755 Avocado Blvd | #516 | LaMesa, CA 91942
858.735.1858 cell
Skype - matthew.reid.ca
matt.reid@landanddesign.com

Check out our new website www.landanddesign.com

Subject: Re: Site "C" Meeting Update

From: Maria Parra <mariap@ci.garden-grove.ca.us>

Date: Wed, 16 Sep 2015 14:29:10 -0700 (PDT)

To: David Rose <drose3@charter.net>

CC: Matthew Reid <matt.reid@landanddesign.com>, zkhan@langdonwilson.com, Greg Blodgett <greg1@ci.garden-grove.ca.us>

Hi David,

We will be available Thursday, September 24th at 3 p.m. Does this day and time work?

Best regards,

Maria Parra

Urban Planner

City of Garden Grove | Planning Services Division

11222 Acacia Parkway, Garden Grove, CA 92840

(714) 741-5312 | (714) 741-5578 fax

mariap@ci.garden-grove.ca.us | www.ci.garden-grove.ca.us

Community Development Department of the City of Garden Grove

"Providing Quality Services Through Creativity and Collaboration"

City Hall Hours:

Monday-Thursday: 7:30 a.m. to 5:30 p.m.

First Friday of the Month: 7:30 a.m. to 5:00 p.m.

Direct Website Links:

[Planning Division](#)

[Municipal Code, Title 9, Land Use](#)

[Zoning Map](#)

From: "David Rose" <drose3@charter.net>

To: "Maria Parra" <mariap@ci.garden-grove.ca.us>

Cc: "Matthew Reid" <matt.reid@landanddesign.com>, zkhan@langdonwilson.com, "Karl Hill" <karlh@ci.garden-grove.ca.us>, "Lee Marino" <leem@ci.garden-grove.ca.us>, "Greg Blodgett" <greg1@ci.garden-grove.ca.us>, "Jane Chang" <jane.chang@aecom.com>, "Jayna Morgan" <Jayna.Morgan@aecom.com>, "David Rose" <drose3@hotmail.com>

Sent: Tuesday, September 15, 2015 6:24:40 PM

Subject: Re: Site "C" Meeting Update

Maria:

I hope this email finds you doing well.

We're ready for our official meeting with the City to present our updates to PUD, etc., for Site "C".

As such, we'd like to set up a meeting with the City and AECOM either for this Friday and/or early next week.

Please advise.

Thanks.

Dave

Sent from my iPhone

Please forgive any errors. 😊

On Aug 19, 2015, at 10:25 AM, Maria Parra <mariap@ci.garden-grove.ca.us> wrote:

Matt:

One last item to note, please forward a copy of the Shade and Shadow Study to AECOM and Planning.

Thank you!

Maria Parra

Urban Planner

City of Garden Grove | Planning Services Division

11222 Acacia Parkway, Garden Grove, CA 92840

(714) 741-5312 | (714) 741-5578 fax

mariap@ci.garden-grove.ca.us | www.ci.garden-grove.ca.us

Community Development Department of the City of Garden Grove

"Providing Quality Services Through Creativity and Collaboration"

City Hall Hours:

Monday-Thursday: 7:30 a.m. to 5:30 p.m.

First Friday of the Month: 7:30 a.m. to 5:00 p.m.

Direct Website Links:

[Planning Division](#)

[Municipal Code, Title 9, Land Use](#)

[Zoning Map](#)

From: "Maria Parra" <mariap@ci.garden-grove.ca.us>

To: "Matthew Reid" <matt.reid@landanddesign.com>, "Dave Rose" <drose3@charter.net>, zkhan@langdonwilson.com, "Karl Hill" <karlh@ci.garden-grove.ca.us>, "Lee Marino" <leem@ci.garden-grove.ca.us>, "Greg Blodgett" <greg1@ci.garden-grove.ca.us>, "Jayan Morgan" <jayan.morgan@aecom.com>, "Jane Chang" <jane.chang@aecom.com>

Sent: Wednesday, August 19, 2015 10:10:40 AM

Subject: Site "C" Meeting Update

All:

Below is a summary of the items necessary to proceed with the CEQA addendum and the Site Plan review.

L&D to:

- Submit to Planning and AECOM a revised project summary per Table 1 of the Mitigated Negative Declaration (see attached MND Table 1 Project Summary).
- Submit a revised, detailed site plan, and building sections to Planning and AECOM. Planning will review the plans with Fire, Building, and Engineering. The plans must also include the proposed building LED sign location(s), dimensions, and square footage. Planning staff will review and discuss the proposed LED signs internally with the policymakers.
- The proposed LED signs will require a light and glare study that will be submitted to AECOM. The LED signs will require an amendment to the PUD.
- To provide a project schedule timeline

I have attached a copy of the Harbor Blvd sidewalk standard and landscaping, and a copy of the Tentative Parcel Map.

Best regards,

Maria Parra

Urban Planner

City of Garden Grove | Planning Services Division

11222 Acacia Parkway, Garden Grove, CA 92840

(714) 741-5312 | (714) 741-5578 fax

mariap@ci.garden-grove.ca.us | www.ci.garden-grove.ca.us

Community Development Department of the City of Garden Grove

"Providing Quality Services Through Creativity and Collaboration"

City Hall Hours:

Monday-Thursday: 7:30 a.m. to 5:30 p.m.

First Friday of the Month: 7:30 a.m. to 5:00 p.m.

Direct Website Links:

[Planning Division](#)

[Municipal Code, Title 9, Land Use](#)

[Zoning Map](#)

Subject: Re: Site "C" Meeting Update
From: Maria Parra <mariap@ci.garden-grove.ca.us>
Date: Wed, 16 Sep 2015 14:59:31 -0700 (PDT)
To: David Rose <drose3@charter.net>
CC: Matthew Reid <matt.reid@landanddesign.com>, zkhan@langdonwilson.com, Greg Blodgett <greg1@ci.garden-grove.ca.us>

Hi David,

We scheduled the meeting for the Site "C" Update Tuesday, September 22nd at 3:30 p.m. in the 3rd Floor Training Room of City Hall.

Best regards,

Maria Parra

Urban Planner
City of Garden Grove | Planning Services Division
11222 Acacia Parkway, Garden Grove, CA 92840
(714) 741-5312 | (714) 741-5578 fax
mariap@ci.garden-grove.ca.us | www.ci.garden-grove.ca.us

Community Development Department of the City of Garden Grove
"Providing Quality Services Through Creativity and Collaboration"

City Hall Hours:

Monday-Thursday: 7:30 a.m. to 5:30 p.m.
First Friday of the Month: 7:30 a.m. to 5:00 p.m.

Direct Website Links:

[Planning Division](#)
[Municipal Code, Title 9, Land Use](#)
[Zoning Map](#)

From: "Maria Parra" <mariap@ci.garden-grove.ca.us>
To: "David Rose" <drose3@charter.net>
Cc: "Matthew Reid" <matt.reid@landanddesign.com>, zkhan@langdonwilson.com, "Greg Blodgett" <greg1@ci.garden-grove.ca.us>
Sent: Wednesday, September 16, 2015 2:29:10 PM
Subject: Re: Site "C" Meeting Update

Hi David,

We will be available Thursday, September 24th at 3 p.m. Does this day and time work?

Best regards,

Maria Parra

Urban Planner
City of Garden Grove | Planning Services Division
11222 Acacia Parkway, Garden Grove, CA 92840
(714) 741-5312 | (714) 741-5578 fax
mariap@ci.garden-grove.ca.us | www.ci.garden-grove.ca.us

Community Development Department of the City of Garden Grove
"Providing Quality Services Through Creativity and Collaboration"

City Hall Hours:
Monday-Thursday: 7:30 a.m. to 5:30 p.m.
First Friday of the Month: 7:30 a.m. to 5:00 p.m.

Direct Website Links:
[Planning Division](#)
[Municipal Code, Title 9, Land Use](#)
[Zoning Map](#)

From: "David Rose" <drose3@charter.net>
To: "Maria Parra" <mariap@ci.garden-grove.ca.us>
Cc: "Matthew Reid" <matt.reid@landanddesign.com>, zkhan@langdonwilson.com, "Karl Hill" <karlh@ci.garden-grove.ca.us>, "Lee Marino" <leem@ci.garden-grove.ca.us>, "Greg Blodgett" <greg1@ci.garden-grove.ca.us>, "Jane Chang" <jane.chang@aecom.com>, "Jayna Morgan" <Jayna.Morgan@aecom.com>, "David Rose" <drose3@hotmail.com>
Sent: Tuesday, September 15, 2015 6:24:40 PM
Subject: Re: Site "C" Meeting Update

Maria:

I hope this email finds you doing well.

We're ready for our official meeting with the City to present our updates to PUD, etc., for Site "C".

As such, we'd like to set up a meeting with the City and AECOM either for this Friday and/or early next week.

Please advise.

Thanks.

Dave

Sent from my iPhone

Please forgive any errors. 😊

On Aug 19, 2015, at 10:25 AM, Maria Parra <mariap@ci.garden-grove.ca.us> wrote:

Matt:

One last item to note, please forward a copy of the Shade and Shadow Study to AECOM and Planning.

Thank you!

Maria Parra

Urban Planner

City of Garden Grove | Planning Services Division

11222 Acacia Parkway, Garden Grove, CA 92840

(714) 741-5312 | (714) 741-5578 fax

mariap@ci.garden-grove.ca.us | www.ci.garden-grove.ca.us

Community Development Department of the City of Garden Grove

"Providing Quality Services Through Creativity and Collaboration"

City Hall Hours:

Monday-Thursday: 7:30 a.m. to 5:30 p.m.

First Friday of the Month: 7:30 a.m. to 5:00 p.m.

Direct Website Links:

[Planning Division](#)

[Municipal Code, Title 9, Land Use](#)

[Zoning Map](#)

From: "Maria Parra" <mariap@ci.garden-grove.ca.us>
To: "Matthew Reid" <matt.reid@landanddesign.com>, "Dave Rose" <drose3@charter.net>, zkhan@langdonwilson.com, "Karl Hill" <karlh@ci.garden-grove.ca.us>, "Lee Marino" <leem@ci.garden-grove.ca.us>, "Greg Blodgett" <greg1@ci.garden-grove.ca.us>, "Jayan Morgan" <jayan.morgan@aecom.com>, "Jane Chang" <jane.chang@aecom.com>
Sent: Wednesday, August 19, 2015 10:10:40 AM
Subject: Site "C" Meeting Update

All:

Below is a summary of the items necessary to proceed with the CEQA addendum and the Site Plan review.

L&D to:

- Submit to Planning and AECOM a revised project summary per Table 1 of the Mitigated Negative Declaration (see attached MND Table 1 Project Summary).
- Submit a revised, detailed site plan, and building sections to Planning and AECOM. Planning will review the plans with Fire, Building, and Engineering. The plans must also include the proposed building LED sign location(s), dimensions, and square footage. Planning staff will review and discuss the proposed LED signs internally with the policymakers.
- The proposed LED signs will require a light and glare study that will be submitted to AECOM. The LED signs will require an amendment to the PUD.
- To provide a project schedule timeline

I have attached a copy of the Harbor Blvd sidewalk standard and landscaping, and a copy of the Tentative Parcel Map.

Best regards,

Maria Parra

Urban Planner

City of Garden Grove | Planning Services Division

11222 Acacia Parkway, Garden Grove, CA 92840

(714) 741-5312 | (714) 741-5578 fax

mariap@ci.garden-grove.ca.us | www.ci.garden-grove.ca.us

Community Development Department of the City of Garden Grove

"Providing Quality Services Through Creativity and Collaboration"

City Hall Hours:

Monday-Thursday: 7:30 a.m. to 5:30 p.m.

First Friday of the Month: 7:30 a.m. to 5:00 p.m.

Direct Website Links:

[Planning Division](#)

[Municipal Code, Title 9, Land Use](#)

[Zoning Map](#)

Subject: Re: Site "C" Meeting Update

From: David Rose <drose3@charter.net>

Date: Wed, 16 Sep 2015 15:02:00 -0700

To: Maria Parra <mariap@ci.garden-grove.ca.us>

CC: Matthew Reid <matt.reid@landanddesign.com>, "zkhan@langdonwilson.com" <zkhan@langdonwilson.com>, Greg Blodgett <greg1@ci.garden-grove.ca.us>, David Rose <drose3@hotmail.com>

Maria:

Greg sent out an invitation for Tuesday, September 22, 2015, which includes Scott and Karl, and said he coordinated it with you.

Please advise ASAP.

Thanks.

Dave

Sent from my iPhone

Please forgive any errors. 😊

On Sep 16, 2015, at 2:29 PM, Maria Parra <mariap@ci.garden-grove.ca.us> wrote:

Hi David,

We will be available Thursday, September 24th at 3 p.m. Does this day and time work?

Best regards,

Maria Parra

Urban Planner

City of Garden Grove | Planning Services Division

11222 Acacia Parkway, Garden Grove, CA 92840

(714) 741-5312 | (714) 741-5578 fax

mariap@ci.garden-grove.ca.us | www.ci.garden-grove.ca.us

Community Development Department of the City of Garden Grove

"Providing Quality Services Through Creativity and Collaboration"

City Hall Hours:

Monday-Thursday: 7:30 a.m. to 5:30 p.m.

First Friday of the Month: 7:30 a.m. to 5:00 p.m.

Direct Website Links:

[Planning Division](#)

[Municipal Code, Title 9, Land Use](#)

[Zoning Map](#)

From: "David Rose" <drose3@charter.net>
To: "Maria Parra" <mariap@ci.garden-grove.ca.us>
Cc: "Matthew Reid" <matt.reid@landanddesign.com>, zkhan@langdonwilson.com, "Karl Hill" <karlh@ci.garden-grove.ca.us>, "Lee Marino" <leem@ci.garden-grove.ca.us>, "Greg Blodgett" <greg1@ci.garden-grove.ca.us>, "Jane Chang" <jane.chang@aecom.com>, "Jayna Morgan" <Jayna.Morgan@aecom.com>, "David Rose" <drose3@hotmail.com>
Sent: Tuesday, September 15, 2015 6:24:40 PM
Subject: Re: Site "C" Meeting Update

Maria:

I hope this email finds you doing well.

We're ready for our official meeting with the City to present our updates to PUD, etc., for Site "C".

As such, we'd like to set up a meeting with the City and AECOM either for this Friday and/or early next week.

Please advise.

Thanks.

Dave

Sent from my iPhone

Please forgive any errors. ☺

On Aug 19, 2015, at 10:25 AM, Maria Parra <mariap@ci.garden-grove.ca.us> wrote:

Matt:

One last item to note, please forward a copy of the Shade and Shadow Study to AECOM and Planning.

Thank you!

Maria Parra

Urban Planner

City of Garden Grove | Planning Services Division

11222 Acacia Parkway, Garden Grove, CA 92840

(714) 741-5312 | (714) 741-5578 fax

mariap@ci.garden-grove.ca.us | www.ci.garden-grove.ca.us

Community Development Department of the City of Garden Grove
"Providing Quality Services Through Creativity and Collaboration"

City Hall Hours:

Monday-Thursday: 7:30 a.m. to 5:30 p.m.

First Friday of the Month: 7:30 a.m. to 5:00 p.m.

Direct Website Links:

Planning Division

Municipal Code, Title 9, Land Use

Zoning Map

From: "Maria Parra" <mariap@ci.garden-grove.ca.us>
To: "Matthew Reid" <matt.reid@landanddesign.com>, "Dave Rose" <drose3@charter.net>, zkhan@langdonwilson.com, "Karl Hill" <karlh@ci.garden-grove.ca.us>, "Lee Marino" <leem@ci.garden-grove.ca.us>, "Greg Blodgett" <greg1@ci.garden-grove.ca.us>, "jayan morgan" <jayan.morgan@aecom.com>, "Jane Chang" <jane.chang@aecom.com>
Sent: Wednesday, August 19, 2015 10:10:40 AM
Subject: Site "C" Meeting Update

All:

Below is a summary of the items necessary to proceed with the CEQA addendum and the Site Plan review.

L&D to:

- Submit to Planning and AECOM a revised project summary per Table 1 of the Mitigated Negative Declaration (see attached MND Table 1 Project Summary).
- Submit a revised, detailed site plan, and building sections to Planning and AECOM. Planning will review the plans with Fire, Building, and Engineering. The plans must also include the proposed building LED sign location(s), dimensions, and square footage. Planning staff will review and discuss the proposed LED signs internally with the policymakers.
- The proposed LED signs will require a light and glare study that will be submitted to AECOM. The LED signs will require an amendment to the PUD.
- To provide a project schedule timeline

I have attached a copy of the Harbor Blvd sidewalk standard and landscaping, and a copy of the Tentative Parcel Map.

Best regards,

Maria Parra

Urban Planner

City of Garden Grove | Planning Services Division

11222 Acacia Parkway, Garden Grove, CA 92840

(714) 741-5312 | (714) 741-5578 fax

mariap@ci.garden-grove.ca.us | www.ci.garden-grove.ca.us

Community Development Department of the City of Garden Grove

"Providing Quality Services Through Creativity and Collaboration"

City Hall Hours:

Monday-Thursday: 7:30 a.m. to 5:30 p.m.

First Friday of the Month: 7:30 a.m. to 5:00 p.m.

Direct Website Links:

[Planning Division](#)

[Municipal Code, Title 9, Land Use](#)

[Zoning Map](#)

Subject: Re: Site "C" Meeting Update

From: Maria Parra <mariap@ci.garden-grove.ca.us>

Date: Wed, 16 Sep 2015 15:18:36 -0700 (PDT)

To: David Rose <drose3@charter.net>

CC: Matthew Reid <matt.reid@landanddesign.com>, zkhan@langdonwilson.com, Greg Blodgett <greg1@ci.garden-grove.ca.us>, David Rose <drose3@hotmail.com>

Hi David,

I was unaware that the meeting had been scheduled for Tuesday the 22nd when I sent my original e-mail. I did ask Greg that due to meeting conflict, to move the meeting to 3:30 p.m. I have asked Greg to update the invite to reflect the new time slot. AECOM also confirmed for 3:30 p.m.

Thanks!

Maria Parra

Urban Planner

City of Garden Grove | Planning Services Division

11222 Acacia Parkway, Garden Grove, CA 92840

(714) 741-5312 | (714) 741-5578 fax

mariap@ci.garden-grove.ca.us | www.ci.garden-grove.ca.us

Community Development Department of the City of Garden Grove

"Providing Quality Services Through Creativity and Collaboration"

City Hall Hours:

Monday-Thursday: 7:30 a.m. to 5:30 p.m.

First Friday of the Month: 7:30 a.m. to 5:00 p.m.

Direct Website Links:

[Planning Division](#)

[Municipal Code, Title 9, Land Use](#)

[Zoning Map](#)

From: "David Rose" <drose3@charter.net>

To: "Maria Parra" <mariap@ci.garden-grove.ca.us>

Cc: "Matthew Reid" <matt.reid@landanddesign.com>, zkhan@langdonwilson.com, "Greg Blodgett" <greg1@ci.garden-grove.ca.us>, "David Rose" <drose3@hotmail.com>

Sent: Wednesday, September 16, 2015 3:02:00 PM

Subject: Re: Site "C" Meeting Update

Maria:

Greg sent out an invitation for Tuesday, September 22, 2015, which includes Scott and Karl,

and said he coordinated it with you.

Please advise ASAP.

Thanks.

Dave

Sent from my iPhone

Please forgive any errors. ☺

On Sep 16, 2015, at 2:29 PM, Maria Parra <mariap@ci.garden-grove.ca.us> wrote:

Hi David,

We will be available Thursday, September 24th at 3 p.m. Does this day and time work?

Best regards,

Maria Parra

Urban Planner

City of Garden Grove | Planning Services Division

11222 Acacia Parkway, Garden Grove, CA 92840

(714) 741-5312 | (714) 741-5578 fax

mariap@ci.garden-grove.ca.us | www.ci.garden-grove.ca.us

Community Development Department of the City of Garden Grove

"Providing Quality Services Through Creativity and Collaboration"

City Hall Hours:

Monday-Thursday: 7:30 a.m. to 5:30 p.m.

First Friday of the Month: 7:30 a.m. to 5:00 p.m.

Direct Website Links:

[Planning Division](#)

[Municipal Code, Title 9, Land Use](#)

[Zoning Map](#)

From: "David Rose" <drose3@charter.net>

To: "Maria Parra" <mariap@ci.garden-grove.ca.us>

Cc: "Matthew Reid" <matt.reid@landanddesign.com>, zkhan@langdonwilson.com, "Karl Hill" <karlh@ci.garden-grove.ca.us>, "Lee Marino" <leem@ci.garden-grove.ca.us>, "Greg Blodgett" <greg1@ci.garden-grove.ca.us>

grove.ca.us>, "Jane Chang" <jane.chang@aecom.com>, "Jayna Morgan" <Jayna.Morgan@aecom.com>, "David Rose" <drose3@hotmail.com>

Sent: Tuesday, September 15, 2015 6:24:40 PM

Subject: Re: Site "C" Meeting Update

Maria:

I hope this email finds you doing well.

We're ready for our official meeting with the City to present our updates to PUD, etc., for Site "C".

As such, we'd like to set up a meeting with the City and AECOM either for this Friday and/or early next week.

Please advise.

Thanks.

Dave

Sent from my iPhone

Please forgive any errors. 😊

On Aug 19, 2015, at 10:25 AM, Maria Parra <mariap@ci.garden-grove.ca.us> wrote:

Matt:

One last item to note, please forward a copy of the Shade and Shadow Study to AECOM and Planning.

Thank you!

Maria Parra

Urban Planner

City of Garden Grove | Planning Services Division

11222 Acacia Parkway, Garden Grove, CA 92840

(714) 741-5312 | (714) 741-5578 fax

mariap@ci.garden-grove.ca.us | www.ci.garden-grove.ca.us

Community Development Department of the City of Garden Grove

"Providing Quality Services Through Creativity and Collaboration"

City Hall Hours:

Monday-Thursday: 7:30 a.m. to 5:30 p.m.

First Friday of the Month: 7:30 a.m. to 5:00 p.m.

Direct Website Links:
[Planning Division](#)
[Municipal Code, Title 9, Land Use](#)
[Zoning Map](#)

From: "Maria Parra" <mariap@ci.garden-grove.ca.us>
To: "Matthew Reid" <matt.reid@landanddesign.com>, "Dave Rose" <drose3@charter.net>, zkhan@langdonwilson.com, "Karl Hill" <karlh@ci.garden-grove.ca.us>, "Lee Marino" <leem@ci.garden-grove.ca.us>, "Greg Blodgett" <greg1@ci.garden-grove.ca.us>, "Jayan morgan" <jayan.morgan@aecom.com>, "Jane Chang" <jane.chang@aecom.com>
Sent: Wednesday, August 19, 2015 10:10:40 AM
Subject: Site "C" Meeting Update

All:

Below is a summary of the items necessary to proceed with the CEQA addendum and the Site Plan review.

L&D to:

- Submit to Planning and AECOM a revised project summary per Table 1 of the Mitigated Negative Declaration (see attached MND Table 1 Project Summary).
- Submit a revised, detailed site plan, and building sections to Planning and AECOM. Planning will review the plans with Fire, Building, and Engineering. The plans must also include the proposed building LED sign location(s), dimensions, and square footage. Planning staff will review and discuss the proposed LED signs internally with the policymakers.
- The proposed LED signs will require a light and glare study that will be submitted to AECOM. The LED signs will require an amendment to the PUD.
- To provide a project schedule timeline

I have attached a copy of the Harbor Blvd sidewalk standard and landscaping, and a copy of the Tentative Parcel Map.

Best regards,

Maria Parra

Urban Planner
City of Garden Grove | Planning Services Division
11222 Acacia Parkway, Garden Grove, CA 92840

(714) 741-5312 | (714) 741-5578 fax
mariap@ci.garden-grove.ca.us | www.ci.garden-grove.ca.us

Community Development Department of the City of Garden Grove
"Providing Quality Services Through Creativity and Collaboration"

City Hall Hours:

Monday-Thursday: 7:30 a.m. to 5:30 p.m.

First Friday of the Month: 7:30 a.m. to 5:00 p.m.

Direct Website Links:

[Planning Division](#)

[Municipal Code, Title 9, Land Use](#)

[Zoning Map](#)

Subject: Re: Resort Hotel Matt Reid
From: David Rose <drose3@charter.net>
Date: Wed, 16 Sep 2015 17:17:06 -0700
To: Greg Blodgett <greg1@ci.garden-grove.ca.us>
CC: Karl Hill <karlh@ci.garden-grove.ca.us>, "kingsley@ci.garden-grove.ca.us" <kingsley@ci.garden-grove.ca.us>, Scott Stiles <sstiles@ci.garden-grove.ca.us>, "Lee, Grace E." <gracel@ci.garden-grove.ca.us>, Matthew Reid <matt.reid@landanddesign.com>, ziad kahn <zkhan@langdonwilson.com>, "ch3_training@ci.garden-grove.ca.us" <ch3_training@ci.garden-grove.ca.us>, David Rose <drose3@hotmail.com>

Greg:

Maria is proposing the meeting for Thursday NOT Tuesday.

Please advise.

Thanks.

Dave

Sent from my iPhone

Please forgive any errors. ☺

On Sep 16, 2015, at 3:00 PM, Greg Blodgett <greg1@ci.garden-grove.ca.us> wrote:

The following meeting has been modified:

Subject: Resort Hotel Matt Reid

Organizer: "Greg Blodgett" <greg1@ci.garden-grove.ca.us>

Location: "CH3_Training" <ch3_training@ci.garden-grove.ca.us> [MODIFIED]

Resources: ch3_training@ci.garden-grove.ca.us [MODIFIED]

Time: Tuesday, September 22, 2015, 3:30:00 PM - 4:30:00 PM GMT -08:00 US/Canada Pacific [MODIFIED]

drose3@charter.net; karlh@ci.garden-grove.ca.us; kingsley@ci.garden-grove.ca.us;

Invitees: sstiles@ci.garden-grove.ca.us; gracel@ci.garden-grove.ca.us;

matt.reid@landanddesign.com; drose3@charter.net; zkhan@langdonwilson.com

~~*~*~*~*~*~*~*~*

<meeting.ics>

Subject: Re: Resort Hotel Matt Reid
From: Greg Blodgett <greg1@ci.garden-grove.ca.us>
Date: Wed, 16 Sep 2015 17:43:52 -0700 (PDT)
To: David Rose <drose3@charter.net>

tuesday

----- Original Message -----

From: "David Rose" <drose3@charter.net>
To: "Greg Blodgett" <greg1@ci.garden-grove.ca.us>
Cc: "Karl Hill" <karlh@ci.garden-grove.ca.us>, kingsley@ci.garden-grove.ca.us,
"Scott Stiles" <sstiles@ci.garden-grove.ca.us>, "Grace E. Lee" <gracel@ci.garden-grove.ca.us>, "Matthew Reid" <matt.reid@landanddesign.com>, "ziad kahn" <zkhan@langdonwilson.com>, "ch3 training" <ch3_training@ci.garden-grove.ca.us>, "David Rose" <drose3@hotmail.com>
Sent: Wednesday, September 16, 2015 5:17:06 PM
Subject: Re: Resort Hotel Matt Reid

Greg:

Maria is proposing the meeting for Thursday NOT Tuesday.

Please advise.

Thanks.

Dave

Sent from my iPhone

Please forgive any errors. ☺

On Sep 16, 2015, at 3:00 PM, Greg Blodgett <greg1@ci.garden-grove.ca.us > wrote:

The following meeting has been modified:

Subject: Resort Hotel Matt Reid
Organizer: "Greg Blodgett" <greg1@ci.garden-grove.ca.us >
Location: "CH3_Training" <ch3_training@ci.garden-grove.ca.us > [MODIFIED]
Resources: ch3_training@ci.garden-grove.ca.us [MODIFIED]
Time: Tuesday, September 22, 2015, 3:30:00 PM - 4:30:00 PM GMT -08:00 US/Canada Pacific [MODIFIED]
Invitees: drose3@charter.net ; karlh@ci.garden-grove.ca.us ; kingsley@ci.garden-grove.ca.us ; sstiles@ci.garden-grove.ca.us ; gracel@ci.garden-grove.ca.us ; matt.reid@landanddesign.com ; drose3@charter.net ; zkhan@langdonwilson.com

Subject: Re: Site "C" Meeting Update
From: David Rose <drose3@charter.net>
Date: Wed, 16 Sep 2015 19:19:28 -0700
To: Maria Parra <mariap@ci.garden-grove.ca.us>
CC: Matthew Reid <matt.reid@landanddesign.com>, "zkhan@langdonwilson.com" <zkhan@langdonwilson.com>, Greg Blodgett <greg1@ci.garden-grove.ca.us>, David Rose <drose3@hotmail.com>

Great.

Sorry for confusion.

Thanks.

Dave

Sent from my iPhone

Please forgive any errors. ☺

On Sep 16, 2015, at 2:59 PM, Maria Parra <mariap@ci.garden-grove.ca.us> wrote:

Hi David,

We scheduled the meeting for the Site "C" Update Tuesday, September 22nd at 3:30 p.m. in the 3rd Floor Training Room of City Hall.

Best regards,

Maria Parra

Urban Planner
City of Garden Grove | Planning Services Division
11222 Acacia Parkway, Garden Grove, CA 92840
(714) 741-5312 | (714) 741-5578 fax
mariap@ci.garden-grove.ca.us | www.ci.garden-grove.ca.us

Community Development Department of the City of Garden Grove
"Providing Quality Services Through Creativity and Collaboration"

City Hall Hours:
Monday-Thursday: 7:30 a.m. to 5:30 p.m.
First Friday of the Month: 7:30 a.m. to 5:00 p.m.

Direct Website Links:
[Planning Division](#)
[Municipal Code, Title 9, Land Use](#)
[Zoning Map](#)

From: "Maria Parra" <mariap@ci.garden-grove.ca.us>
To: "David Rose" <drose3@charter.net>
Cc: "Matthew Reid" <matt.reid@landanddesign.com>, zkhan@langdonwilson.com, "Greg Blodgett" <greg1@ci.garden-grove.ca.us>
Sent: Wednesday, September 16, 2015 2:29:10 PM
Subject: Re: Site "C" Meeting Update

Hi David,

We will be available Thursday, September 24th at 3 p.m. Does this day and time work?

Best regards,

Maria Parra

Urban Planner
City of Garden Grove | Planning Services Division
11222 Acacia Parkway, Garden Grove, CA 92840
(714) 741-5312 | (714) 741-5578 fax
mariap@ci.garden-grove.ca.us | www.ci.garden-grove.ca.us

Community Development Department of the City of Garden Grove
"Providing Quality Services Through Creativity and Collaboration"

City Hall Hours:
Monday-Thursday: 7:30 a.m. to 5:30 p.m.
First Friday of the Month: 7:30 a.m. to 5:00 p.m.

Direct Website Links:
[Planning Division](#)
[Municipal Code, Title 9, Land Use](#)
[Zoning Map](#)

From: "David Rose" <drose3@charter.net>
To: "Maria Parra" <mariap@ci.garden-grove.ca.us>
Cc: "Matthew Reid" <matt.reid@landanddesign.com>, zkhan@langdonwilson.com, "Karl Hill" <karlh@ci.garden-grove.ca.us>, "Lee Marino" <leem@ci.garden-grove.ca.us>, "Greg Blodgett" <greg1@ci.garden-grove.ca.us>, "Jane Chang" <jane.chang@aecom.com>, "Jayna Morgan" <Jayna.Morgan@aecom.com>, "David Rose" <drose3@hotmail.com>
Sent: Tuesday, September 15, 2015 6:24:40 PM
Subject: Re: Site "C" Meeting Update

Maria:

I hope this email finds you doing well.

We're ready for our official meeting with the City to present our updates to PUD, etc., for Site "C".

As such, we'd like to set up a meeting with the City and AECOM either for this Friday and/or early next week.

Please advise.

Thanks.

Dave

Sent from my iPhone

Please forgive any errors. 😊

On Aug 19, 2015, at 10:25 AM, Maria Parra <mariap@ci.garden-grove.ca.us> wrote:

Matt:

One last item to note, please forward a copy of the Shade and Shadow Study to AECOM and Planning.

Thank you!

Maria Parra

Urban Planner
City of Garden Grove | Planning Services Division
11222 Acacia Parkway, Garden Grove, CA 92840
(714) 741-5312 | (714) 741-5578 fax
mariap@ci.garden-grove.ca.us | www.ci.garden-grove.ca.us

Community Development Department of the City of Garden Grove
"Providing Quality Services Through Creativity and Collaboration"

City Hall Hours:
Monday-Thursday: 7:30 a.m. to 5:30 p.m.
First Friday of the Month: 7:30 a.m. to 5:00 p.m.

Direct Website Links:
[Planning Division](#)
[Municipal Code, Title 9, Land Use](#)
[Zoning Map](#)

From: "Maria Parra" <mariap@ci.garden-grove.ca.us>
To: "Matthew Reid" <matt.reid@landanddesign.com>, "Dave Rose" <drose3@charter.net>, zkhan@langdonwilson.com, "Karl Hill" <karlh@ci.garden-grove.ca.us>, "Lee Marino" <leem@ci.garden-grove.ca.us>, "Greg Blodgett" <greg1@ci.garden-grove.ca.us>, "jayan morgan" <jayan.morgan@aecom.com>, "Jane Chang" <jane.chang@aecom.com>
Sent: Wednesday, August 19, 2015 10:10:40 AM
Subject: Site "C" Meeting Update

All:

Below is a summary of the items necessary to proceed with the CEQA addendum and the Site Plan review.

L&D to:

- Submit to Planning and AECOM a revised project summary per Table 1 of the Mitigated Negative Declaration (see attached MND Table 1 Project Summary).
- Submit a revised, detailed site plan, and building sections to Planning and AECOM. Planning will review the plans with Fire, Building, and Engineering. The plans must also include the proposed building LED sign location(s), dimensions, and square footage. Planning staff will review and discuss the proposed LED signs internally with the policymakers.
- The proposed LED signs will require a light and glare study that will be submitted to AECOM. The LED signs will require an amendment to the PUD.
- To provide a project schedule timeline

I have attached a copy of the Harbor Blvd sidewalk standard and landscaping, and a copy of the Tentative Parcel Map.

Best regards,

Maria Parra

Urban Planner
City of Garden Grove | Planning Services Division
11222 Acacia Parkway, Garden Grove, CA 92840
(714) 741-5312 | (714) 741-5578 fax
mariap@ci.garden-grove.ca.us | www.ci.garden-grove.ca.us

Community Development Department of the City of Garden Grove
"Providing Quality Services Through Creativity and Collaboration"

City Hall Hours:
Monday-Thursday: 7:30 a.m. to 5:30 p.m.
First Friday of the Month: 7:30 a.m. to 5:00 p.m.

Direct Website Links:
[Planning Division](#)
[Municipal Code, Title 9, Land Use](#)

Zoning Map

Subject: New Contact Info

From: "Morgan, Jayna" <jmorga12@wm.com>

Date: Fri, 18 Sep 2015 18:45:57 +0000

To: Maria Parra <mariap@ci.garden-grove.ca.us>, Matthew Reid <matt.reid@landanddesign.com>, Dave Rose <drose3@charter.net>, "zkhan@langdonwilson.com" <zkhan@langdonwilson.com>, Karl Hill <karlh@ci.garden-grove.ca.us>, Lee Marino <leem@ci.garden-grove.ca.us>, "Greg Blodgett" <greg1@ci.garden-grove.ca.us>

Hi All-

Jane and I met yesterday on another project and she mentioned that you have a kick off meeting for the Site C MND addendum next week. I wish you all the best with the project and do not hesitate to email me with updates.

I am finally getting settled into my new position but the first few weeks they had me running ragged!

Enjoy your weekend and stay in touch!

Jayna Morgan
Environmental Protection Specialist
Southern California Market Area
jmorga12@wm.com

Waste Management
2050 N Glassell St.
Orange, CA 92865
Tel 714 450 4342
Cell 714 588 0590

Recycling is a good thing. Please recycle any printed emails.

Subject: Agenda for today
From: Matthew Reid <matt.reid@landanddesign.com>
Date: Tue, 22 Sep 2015 06:24:36 -0700
To: Greg Blodgett <Greg1@ci.garden-grove.ca.us>

Greg,
Attached agenda for today.

See you at 3.30pm.

Matthew Reid
Land & Design, Inc.
3755 Avocado Blvd | #516 | LaMesa, CA 91942
858.735.1858 cell
Skype - [matthew.reid.ca](https://www.skype.com/people/matthew.reid.ca)
matt.reid@landanddesign.com

Check out our new website www.landanddesign.com

2015_09_22 entitlemnt mtg AGENDA.pdf	Content-Type: application/pdf Content-Encoding: base64
---	---

— Part 1.1.3 —

Part 1.1.3	Content-Type: text/html Content-Encoding: quoted-printable
-------------------	---

LAND & DESIGN, INC.

CONSTRUCTION | DEVELOPMENT | SUSTAINABLE INTEGRATION

3755 Avocado Blvd, #516 | La Mesa, CA 91941 | 619.567.2447 o | 619.489.3669 f | www.landanddesign.com

AGENDA

Site “C” Entitlement Amendment | Signage Program Meeting September 22, 2015, 3.30pm

- I. Overview of Current Entitlements vs Proposed Project.
 - a. **NOTE: LND is NOT requesting a change to the current entitlements.**
 - b. Shade and Shadow
 - c. Building Heights
 - d. Hotel Keys | SF'g
- II. Review of Proposed Signage Program
- III. Establish Timeline to City Council
- IV. Other items necessary for Amendment
- V. Q&A

Re: Agenda for today

Subject: Re: Agenda for today
From: Greg Blodgett <greg1@ci.garden-grove.ca.us>
Date: Tue, 22 Sep 2015 09:01:46 -0700 (PDT)
To: Matthew Reid <matt.reid@landanddesign.com>

Any update on the brain bridge partnership

Sent from my iPhone

On Sep 22, 2015, at 6:24 AM, Matthew Reid <matt.reid@landanddesign.com> wrote:

Greg,
Attached agenda for today.

See you at 3.30pm.

<2015_09_22 entitlemnt mtg AGENDA.pdf>

Matthew Reid
Land & Design, Inc.
3755 Avocado Blvd | #516 | LaMesa, CA 91942
858.735.1858 cell
Skype - [matthew.reid.ca](https://www.skype.com/user/matthew.reid.ca)
matt.reid@landanddesign.com

Check out our new website www.landanddesign.com

Subject: Site C - Data Needs

From: "Chang, Jane" <Jane.Chang@aecom.com>

Date: Wed, 23 Sep 2015 17:30:23 +0000

To: "matt.reid@landanddesign.com" <matt.reid@landanddesign.com>, "zkhan@langdonwilson.com" <zkhan@langdonwilson.com>, "drose3@hotmail.com" <drose3@hotmail.com>, "Maria Parra (mariap@ci.garden-grove.ca.us)" <mariap@ci.garden-grove.ca.us>, "karlh@ci.garden-grove.ca.us" <karlh@ci.garden-grove.ca.us>, "leem@ci.garden-grove.ca.us" <leem@ci.garden-grove.ca.us>, "greg1@ci.garden-grove.ca.us" <greg1@ci.garden-grove.ca.us>

Good morning.

Per yesterday's meeting, the following lists information needed to prepare the addendum to IS/MND for the International West Hotel – Harbor East (Site C) Project.

- Project Summary Table similar to the attached document
- PDF copy of yesterday's presentation
- Shade and Shadow Study
- Brief description of the proposed lighting/signage

I spoke with Rogier Goedecke at the RK Engineering and he proposed to update the air quality, noise and traffic studies to confirm that the proposed changes to the project site would have similar impacts. Once I receive the above-mentioned information, I will forward them to Rogier and based on his review of the provided materials and a discussion with the City Traffic Department, he will provide a scope and fee for his service.

If you have any questions, please give me a call. Thank you.

Jane Chang, LEED AP
Environmental Planner
Design + Planning
D 714.567.2788
jane.chang@aecom.com

AECOM
999 Town & Country Road, Orange, CA 92868
T 714.567.2501 F 714.567.2760
www.aecom.com

Table 1_Project Summary.docx	<p>Content-Description: Table 1_Project Summary.docx</p> <p>Content-Type: application/vnd.openxmlformats-officedocument.wordprocessingml.document</p> <p>Content-Encoding: base64</p>
-------------------------------------	--

Table 1
Project Summary

Total Hotel Rooms (one full-service and two limited-service)	769 keys/rooms
Full-Service Hotel (max. height)	263 ft
Harbor Limited-Service Hotel (max. height)	200 ft
Twintree Limited-Service Hotel (max. height)	130 ft (E. side) to 190 ft (W. side)
Parking Structure / Ballroom & Pre Function (max. height)	85 ft
Parking Structure (East Side) (max. height)	75 ft
Restaurants Off Harbor (max. height) (max. height)	40 ft
Restaurant/Venue Northeast Corner (max. height)	75 ft
Restaurant/Entertainment (four pads @ 7,500 sf and one pad @ 15,000 sf)	45,000 sf
Hotel Restaurant	20,000 sf
Additional Hotel Ancillary	Restaurant, Bars, Fitness Rooms and Spa
Conference/Meeting Banquet	39,000 sf
Parking Spaces Provided	1,297

Subject: Re: Site C - Data Needs

From: Matthew Reid <matt.reid@landanddesign.com>

Date: Wed, 23 Sep 2015 10:47:58 -0700

To: Jane Chang <Jane.Chang@aecom.com>

CC: Ziad Khan <zkh@langdonwilson.com>, David Rose <drose3@hotmail.com>, Maria Parra <maria@ci.garden-grove.ca.us>, Karl Hill <karlh@ci.garden-grove.ca.us>, "leem@ci.garden-grove.ca.us" <leem@ci.garden-grove.ca.us>, Greg Blodgett <gregl@ci.garden-grove.ca.us>

See below....

Matthew Reid

Land & Design, Inc.

3755 Avocado Blvd | #516 | LaMesa, CA 91942

858.735.1858 cell

Skype - [matthew.reid.ca](https://www.skype.com/people/matthew.reid.ca)

matt.reid@landanddesign.com

Check out our new website www.landanddesign.com

On Sep 23, 2015, at 10:30 AM, Chang, Jane <Jane.Chang@aecom.com> wrote:

Good morning.

Per yesterday's meeting, the following lists information needed to prepare the addendum to IS/MND for the International West Hotel – Harbor East (Site C) Project.

- Project Summary Table similar to the attached document Ziad / LWI
- PDF copy of yesterday's presentation link to download: https://www.dropbox.com/s/7qdhzgl8uzztwzr/Entitlement_SIGNAGE_092215.pdf?dl=0
- Shade and Shadow Study Ziad / LWI
- Brief description of the proposed lighting/signage Ziad / LWI

I spoke with Rogier Goedecke at the RK Engineering and he proposed to update the air quality, noise and traffic studies to confirm that the proposed changes to the project site would have similar impacts. Once I receive the above-mentioned information, I will forward them to Rogier and based on his review of the provided materials and a discussion with the City Traffic Department, he will provide a scope and fee for his service.

If you have any questions, please give me a call. Thank you.

Jane Chang, LEED AP
Environmental Planner
Design + Planning
D 714.567.2788
jane.chang@aecom.com

AECOM

999 Town & Country Road, Orange, CA 92868

T 714.567.2501 F 714.567.2760

www.aecom.com

<Table 1_Project Summary.docx>

Subject: RE: Site C - Data Needs
From: "Ziad Khan" <zkhan@langdonwilson.com>
Date: Wed, 23 Sep 2015 17:58:55 -0700
To: "Matthew Reid" <matt.reid@landanddesign.com>, "Jane Chang" <Jane.Chang@aecom.com>
CC: "David Rose" <drose3@hotmail.com>, "Maria Parra" <mariap@ci.garden-grove.ca.us>, "Karl Hill" <karlh@ci.garden-grove.ca.us>, <leem@ci.garden-grove.ca.us>, "Greg Blodgett" <greg1@ci.garden-grove.ca.us>

Jane,

Please see attached the shade and shadow model our design model is under the layer "NEW DESIGN" (Pink) your original model is under the layer "OLD DESIGN" (yellow).

Regards,

Ziad Khan

Langdon Wilson International
1055 Wilshire Blvd. Ste 1500
Los Angeles, California 90017
Phone: 213.250.1186 ext 224
Fax: 213.482.4654
Mobile: 626.688.9468
Email: zkhan@langdonwilson.com
Website: www.langdonwilson.com

From: Matthew Reid [mailto:matt.reid@landanddesign.com]
Sent: Wednesday, September 23, 2015 10:48 AM
To: Jane Chang
Cc: Ziad Khan; David Rose; Maria Parra; Karl Hill; leem@ci.garden-grove.ca.us; Greg Blodgett
Subject: Re: Site C - Data Needs

See below....

Matthew Reid
Land & Design, Inc.
3755 Avocado Blvd | #516 | LaMesa, CA 91942
858.735.1858 cell
Skype - [matthew.reid.ca](https://www.skype.com/people/matthew.reid.ca)
matt.reid@landanddesign.com

Check out our new website www.landanddesign.com

On Sep 23, 2015, at 10:30 AM, Chang, Jane <Jane.Chang@aecom.com> wrote:

Good morning.

Per yesterday's meeting, the following lists information needed to prepare the addendum to IS/MND for the International West Hotel – Harbor East (Site C) Project.

- Project Summary Table similar to the attached document Ziad / LWI
- PDF copy of yesterday's presentation link to download: https://www.dropbox.com/s/7qdhzgl8uzztwzr/Entitlement_SIGNAGE_092215.pdf?dl=0
- Shade and Shadow Study Ziad / LWI
- Brief description of the proposed lighting/signage Ziad / LWI

I spoke with Rogier Goedecke at the RK Engineering and he proposed to update the air quality, noise and traffic studies to confirm that the proposed changes to the project site would have similar impacts. Once I receive the above-mentioned information, I will forward them to Rogier and based on his review of the provided materials and a discussion with the City Traffic Department, he will provide a scope and fee for his service.

If you have any questions, please give me a call. Thank you.

Jane Chang, LEED AP
Environmental Planner
Design + Planning
D 714.567.2788
jane.chang@aecom.com

AECOM
999 Town & Country Road, Orange, CA 92868
T 714.567.2501 F 714.567.2760
www.aecom.com

<Table 1_Project Summary.docx>

SHADE AND SHADOW ANALYSIS2.skp	Content-Type: skip/octet-stream Content-Encoding: base64
---------------------------------------	---

Subject: Site "C" Update

From: Maria Parra <mariap@ci.garden-grove.ca.us>

Date: Thu, 24 Sep 2015 15:30:20 -0700 (PDT)

To: Matthew Reid <matt.reid@landanddesign.com>

CC: David Rose <drose3@charter.net>, Khan Ziad <zkhan@langdonwilson.com>, Lee Marino <leem@ci.garden-grove.ca.us>, Karl Hill <karlh@ci.garden-grove.ca.us>, Jane Chang <jane.chang@aecom.com>, Greg Blodgett <greg1@ci.garden-grove.ca.us>

Hi Matt,

Attached are the approvals for the Hyundai reader board, and the Clear Channel billboard signs.

Also attached is a sample sign program and the Harbor Blvd sign criteria. At your earliest convenience, please submit a revised sign plan that shows the placement of all proposed signage with dimensions, including all individual channel letters and reader boards. The placement of the signs on the building, especially the reader boards, must reflect the worst case scenario. Ziad mentioned that he has a copy of the reader board sign criteria from the City of Los Angeles, please e-mail a copy of the document to me.

Also, below is a list of some of the concerns that Planning Commissioners and residents have raised about reader boards. It's important that your team be prepared to address each point both in the environmental document and at the Public Hearing:

- reader board light output
- angle of light dispersion
- motion/ movement
- image change time
- dimming during certain night hours
- documentation on safety for non-freeway reader boards
- reader board impacts to local street traffic

Best regards,

Maria Parra

Urban Planner

City of Garden Grove | Planning Services Division

11222 Acacia Parkway, Garden Grove, CA 92840

(714) 741-5312 | (714) 741-5578 fax

mariap@ci.garden-grove.ca.us | www.ci.garden-grove.ca.us

Community Development Department of the City of Garden Grove

"Providing Quality Services Through Creativity and Collaboration"

City Hall Hours:

Monday-Thursday: 7:30 a.m. to 5:30 p.m.

First Friday of the Month: 7:30 a.m. to 5:00 p.m.

Direct Website Links:

[Planning Division](#)

[Municipal Code, Title 9, Land Use](#)

[Zoning Map](#)

harbor signage.pdf	Content-Type: application/pdf Content-Encoding: base64
---------------------------	---

—201509241420.pdf

201509241420.pdf	Content-Type: application/pdf Content-Encoding: base64
-------------------------	---

G. Development Directional Signs.

1. Number of Signs Allowed. Each separate land development project within the City limits shall be permitted a total of not more than two directional signs.
2. Determining Number of Signs. For the purpose of this chapter, a sign containing message material that can be viewed from not more than two surfaces of a single structure shall be considered a single sign, provided the maximum distance between the two viewing surfaces shall not exceed two feet at any point.
3. Size and Height. All directional signs shall not be more than 64 square feet in area per face, nor more than 10 feet in height.

H. Temporary Real Estate Signs. Two temporary real estate signs, not to exceed 50 square feet in area per face, or one sign not to exceed 100 square feet in area per face, may be located on any tract recorded within the boundaries of any approved tentative tract map filed with the City in any zone, provided such signs, if in any "R" zone, shall be removed at the end of a 12-month period measured from the date of the resolution of the City Council accepting the public improvements of the tract upon which said sign or signs are located.

I. Temporary Construction Signs. Two signs identifying persons engaged in construction on a site shall be permitted as long as construction is in progress, provided that any time the removal is required for a public purpose, said signs shall be removed at no expense to the City or other public agency. Such signs may not exceed 50 square feet in area per face or one sign not to exceed 100 square feet in area per face.

J. Temporary Advertising Balloons. Temporary advertising balloons consisting of not more than one inflated balloon not exceeding 1,000 cubic feet in size and with no dimension exceeding 30 feet shall be permitted. Only balloon type devices are permitted (no animated or other design styles are permitted). Inflated balloons shall be affixed and securely anchored to an immobile structure. Immobile structures shall not be located in any landscaped areas, parking space or required setback area. The maximum permitted height for temporary advertising balloons is 35 feet above site grade level.

Temporary advertising balloons may only be displayed after receiving a permit for:

1. An approved community event (see Sections 9.08.020.060, 9.12.020.060, and 9.16.020.060); or
2. An approved special event (see Sections 9.08.020.060, 9.12.020.060, and 9.16.020.060); or
3. Upon application and approval of a temporary sign permit and subject to the restrictions listed in Section 9.20.040.C. (2846 § 5, 2014; 2837 § 3, 2014; 2758 § 2, 2009)

9.20.045 Signs—Overlay Design Standards for the International West Resort Area

The Harbor Boulevard Sign Overlay Program Guide, which was attached as Exhibit 1 to and deemed to be a part of the ordinance adopting this section and is on file with the Community Development Department, shall apply to the placement and design of freestanding signs ("sign standards") for properties within the area covered by this section, as well as to the replacement, when required, of existing freestanding signs, which are currently nonconforming, and those that are made nonconforming by enactment of this section. A map showing the properties subject to these sign standards was included in the Harbor Boulevard Sign Overlay Program Guide attached as Exhibit 1 and deemed to be a part of the ordinance adopting this section and is on file with the Community Development Department. The properties subject to this section are generally those properties located along Harbor Boulevard from Wilken Way (City border) to the north side of the Garden Grove Freeway (State Route 22); those properties located on the north side of Garden Grove Boulevard from approximately 1,000 feet west of Harbor Boulevard to approximately 850 feet east of Harbor Boulevard; and those properties located on the south side of Garden Grove Boulevard from approximately 450 feet west of Harbor Boulevard to approximately 1,200 feet east of Harbor Boulevard.

- A. Any newly constructed freestanding sign or nonconforming freestanding sign, which pursuant to any provision in this Code is required to be replaced with a sign conforming to the sign standards, shall

9.20.050

conform to the sign standards as generally depicted in Sign Type "A" below. If in the determination of the Community Development Director installation of a sign conforming to the sign standards in Sign Type "A" would intrude on required setbacks, significantly interfere with the use of or require modification to existing buildings, cause loss of parking so as to render the property nonconforming to parking standards or would substantially interfere with traffic circulation or utilities on the property, a property owner may install a sign conforming to the sign standards as generally depicted in Sign Type "B" below. If the installation of a sign conforming to the sign standards in Sign Type "B" would still result in an impact noted in this subsection, the property owner or lessee of the property, as the case may be, may apply for a minor deviation with the City Manager or designee as provided in Section 9.32.030 of this title; provided that in granting any such minor deviation the City Manager or designee shall provide relief from the sign standards only to the extent necessary to avoid the impacts described in this subsection and shall otherwise apply the sign standards to the fullest extent possible to maintain continuity and consistency with signs conforming to the sign standards.

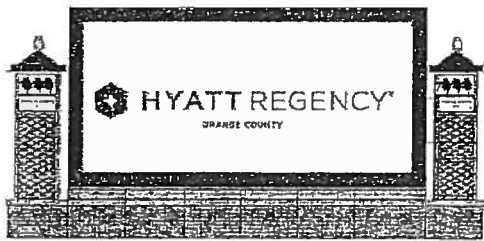

Sign Type "A" (Required)

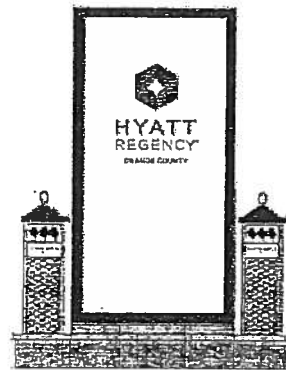

Sign Type "B" (Per Approval)

- B. Properties subject to this section which are within 300 feet of the Garden Grove Freeway right-of-way may, in addition to a freestanding sign complying with this section, have a pole or pylon sign oriented toward the Garden Grove Freeway, which pole or pylon sign shall otherwise comply with applicable provisions of this Code, including, but not limited to, Section 9.20.040.A.1. The 300-foot distance shall be measured in accordance with Section 9.20.040.A.1 of this chapter.
- C. Within the past three years the City has, pursuant to Business and Professions Code Section 5491.1, conducted an identification and inventory of signs which are illegal or abandoned prior to the date this section was adopted and those that will be made nonconforming by adoption of this section. Any nonconforming sign which has been in place for 15 years or more prior to the effective date of the ordinance codified in this section shall be subject to removal six months after the effective date of the ordinance codified in this section; provided that no such sign shall be required to be removed until the City has provided 90 days written notice that the sign is subject to removal pursuant to the provisions of this section. Notice of removal shall be provided to the property owner at the address shown on the latest tax assessment roll and to any existing business advertised on the sign as of the date of such notice.
- D. Prior to requiring removal of any sign made nonconforming by this section, to the extent required by state law, the City shall pay fair and just compensation as provided in Chapter 2.5 of the California Business and Professions Code, Sections 5490 et seq. (2837 § 1, 2014)

9.20.050 Signs—Design Elements

- A. Single Channel Letters. The use of single channel letters is encouraged.
- B. Sign Boxes/Cans. The use of sign boxes or cans will be permitted if recessed or architecturally integrated so as to be flush with the building facade.
- C. The incorporation of the sign face within the architecture or a structure is encouraged.

- D. Illumination. Signs may be illuminated through either indirect or internal illumination. Bare bulb illumination is expressly prohibited.
- E. Architecture. Signs shall be architecturally a part of the design of the building, and should not be an independent feature in conflict with the integrity of building design.
- F. Consistency. Signs located adjacent to one another, or within the same development, should be consistent or compatible in terms of color, material and design.
- G. Reader boards are specifically prohibited on monument or pylon signs. Center identification and up to three tenants may be permitted on pole or pylon signs. Site address(es) shall be included on all monument and pylon signs.
- H. Sign Colors. Sign programs should include a single uniform background color and no more than three colors for sign letters.
- I. Standard Sign Letters. Sign programs should have identifiable, uniform lettering size and style for each tenant type (e.g., major, in-line, etc.).
- J. Electronic Changeable Copy. Notwithstanding subsection G, monument signs with electronic changeable copy are allowed on sites legally established with the following uses: service stations, churches and other religious centers, public and non-profit educational institutions and schools, movie theaters, public buildings, public recreational facilities, and private clubs and lodges. In addition to the general conditions and design standards and elements for signage required under this chapter, signs with electronic changeable copy shall comply with the following requirements. Modifications of existing signs to replace its copy with an electronic changeable copy shall require a new permit per subsection G.
 - 1. For service stations, only those portions of the display surface containing pricing information pursuant to Section 9.20.070 of this chapter may utilize electronic changeable copy.
 - 2. Electronic changeable copy on a sign shall be operated only between the hours of 7:00 a.m. to 10:00 p.m. The sign shall remain dark and unlit between the hours of 10:00 p.m. and 7:00 a.m.
 - 3. A sign with electronic changeable copy shall incorporate both an automatic light sensitive dimmer and a manual dimmer for reducing the intensity of light output in the evening hours (sunset to 10:00 p.m.)
 - 4. The maximum intensity of the light output produced by a sign with electronic changeable copy shall be established in relation to the immediate ambient lighting (darker areas require less intense light levels in the evening hours) and the intensity of light output shall be automatically or manually dimmed in the evening hours (sunset to 10:00 p.m.) so as to minimize impacts to adjacent uses. Under no circumstances may the maximum measurable light output of the electronic changeable copy exceed 0.3 foot-candles above ambient light levels in the evening, to be measured as follows. First, at least 30 minutes past sunset, with the electronic display turned on, a light level reading in foot-candles will be taken with a light meter aimed directly at the electronic display from 100 feet. Second, with the electronic display turned off, showing all black copy or blocked, the light meter will be used at the same location to measure the area ambient light level in foot-candles. The difference between the two readings shall not exceed 0.3 foot-candles.
 - 5. Any lot containing a sign with electronic changeable copy shall have a minimum lot frontage of 160 feet.
 - 6. A sign with an electronic changeable copy shall be located at least 150 feet from another sign with electronic changeable copy, as measured from the base of each such sign.
 - 7. A sign with an electronic changeable copy shall be located at least 80 feet from the property line of any residential property.
 - 8. The electronic changeable copy shall consist only of static letters, symbols and/or numbers (no bright, flashing, moving, strobe type effects or graphics) of a single color against a black (or unlit) background, and shall change no faster than once every 20 seconds.

9.20.060

9. Light intensity changes of the electronic changeable copy (other than between daylight and evening hours) are not permitted. (2846 § 6, 2014; 2758 § 2, 2009)

9.20.060 Permitted Signs

- A. The following table lists those sign types permitted in the respective zoning classifications and subject to the regulations of the division.

SIGN TYPES	R-1	R-2	R-3	O-P	C-1	C-2	C-3	CC	GGMU-1,2,3	AR	NMU	M-1	M-P	O-S
Directional	P	P	P	P	P	P	P	P	P	P	P	P	P	P
Marquee/Canopy	—	—	—	—	P	P	P	P	P	P	P	—	—	—
Nameplate	P	P	P	P	—	—	—	P	P	P	P	—	—	—
Pole	—	—	—	P	P	P	P	—	—	—	—	—	—	—
Pylon	—	—	—	P	P	P	P	—	P	P	P	—	—	—
Political	P	P	P	P	P	P	P	P	P	P	P	P	P	—
Wall	—	—	—	P	P	P	P	P	P	P	P	P	P	—
Monument-Standard	P**	P**	P	P	P	P	P	P	P	P	P	P	P	—
Monument-Tall	—	—	—	—	—	—	—	P*	P	—	P	—	—	—
Temporary	P	P	P	P	P	P	P	P	P	P	P	P	P	—
Community Message Center	—	—	—	P	P	P	P	P	—	—	P	P	P	P
Window	—	—	—	—	P	P	P	P	P	P	P	—	—	—
Sales/Lease/Rental	P	P	P	P	P	P	P	P	P	P	P	P	P	—
Temporary Real Estate	P	P	P	P	P	P	P	P	P	P	P	P	P	—
Temporary Construction	P	P	P	P	P	P	P	P	P	P	P	P	P	—
Projecting/Blade	—	—	—	—	—	—	—	P	P	P	P	—	—	—
Corporate Flag	—	—	—	P	P	P	P	P	P	P	P	P	P	—
Under Canopy/Walkway	—	—	—	P	P	P	P	P	P	P	P	P	P	—
Directory	—	P	P	P	P	P	P	P	P	P	P	P	P	P

* Only permitted in the CC-3 zone.

** Only permitted for the uses listed in Section 9.20.050.J.

B. Allowable Sign Area

- For purposes of calculating maximum permissible signage on a building or on a site or within a development, the following sign types shall be calculated: marquee/canopy, pole, pylon, wall, monument, projecting, corporate flag and under canopy/walkway. These signs shall be known as Group A, and their use shall be subject to the Sign Use Matrix.
- Wall signs are classified as either single channel letters or sign boxes/cans (see Section 9.20.050). In order to specifically encourage the use of single channel letter signs, the following sign area incentive factor may be used: If single channel letters are used, the display surface shall not exceed two and one-half square feet of display area for each lineal foot of building frontage or two square feet of display area for each lineal foot of lot frontage.

- C. The following signs shall be permitted subject to the following criteria.

RESOLUTION NO. 5763-12

A RESOLUTION OF THE PLANNING COMMISSION OF THE CITY OF GARDEN GROVE TO APPROVE CONDITIONAL USE PERMIT NO. CUP-347-12.

BE IT RESOLVED that the Planning Commission of the City of Garden Grove, in regular session assembled on March 1, 2012, does hereby approve Conditional Use Permit No. CUP-347-12 for the property located on the southwest corner of Trask Avenue and Brookhurst Street at 9898 Trask Avenue, Parcel No. 098-090-57 and 58.

BE IT FURTHER RESOLVED in the matter of Conditional Use Permit No. CUP-347-12, the Planning Commission of the City of Garden Grove does hereby report as follows:

1. The subject case was initiated by Jared Hardin.
2. The applicant requested to amend the Sign and Graphics Standards section of Planned Unit Development No. PUD-110-96 zone to allow a 59-foot high freeway-oriented electronic readerboard sign for an automobile dealership located on a minimum two (2) acre site, subject to Conditional Use Permit approval, in conjunction with a request for Conditional Use Permit approval to install a 59-foot high freeway-oriented electronic readerboard sign for an existing automobile dealership (Garden Grove Hyundai) located at 9898 Trask Avenue.
3. The subject site has a General Plan Land Use Designation of Heavy Commercial and is zoned Planned Unit Development No. PUD-110-96.
4. The City of Garden Grove has determined that this project is exempt pursuant to Article 19, Section 15311, Accessory Structures, of the California Environmental Quality Act, and pursuant to Article 5, Section 15061, Review for Exemption, of the California Environmental Quality Act.
5. Existing land use, zoning, and General Plan Land Use designation of the areas included in this Conditional Use Permit and in their vicinity have been reviewed.
6. Report submitted by City staff was reviewed.
7. Pursuant to a legal notice, a public hearing was held on March 1, 2012, and all interested persons were given an opportunity to be heard.
8. The Planning Commission gave due and careful consideration to the matter during its meeting of March 1, 2012; and

BE IT FURTHER RESOLVED, FOUND AND DETERMINED that the facts and reasons supporting the conclusion of the Planning Commission, as required under Municipal Code Section 9.32.030, are as follows:

FACTS:

The subject site is an approximately 2.5 acre property located at the southwest corner of Trask Avenue and Brookhurst Street and is developed with the Garden Grove Hyundai automobile dealership.

In conjunction with the proposed Planned Unit Development Modification (PUD-110-96 (Rev. 12)), the applicant is requesting approval of a Conditional Use Permit for the installation of a 59-foot high freeway-oriented electronic readerboard sign for an existing automobile dealership (Garden Grove Hyundai) located at 9898 Trask Avenue.

FINDINGS AND REASONS:

Conditional Use Permit:

1. That the proposed use will be consistent with the City's adopted General Plan and redevelopment plan.

In conjunction with the associated amendment to Planned Unit Development No. PUD-110-96, the proposed sign will be consistent with the General Plan Land Use Designation of the property, which is Heavy Commercial, provided that the project complies with all conditions of approval.

2. That the requested use at the location proposed will not adversely affect the health, peace, comfort, or welfare of the persons residing or working in the surrounding area.

The installation of a proposed sign will not adversely affect the health, peace, comfort, or welfare of the persons residing or working in the surrounding area. The conditions of approval for the sign will minimize potential impacts to the adjoining area. Provided the conditions of approval for the project are adhered to for the life of the project, the use will be harmonious with persons who work and live in the area.

3. The proposed use will not interfere with the use, enjoyment, or valuation of the property of other persons located in the vicinity of the site.

The proposed sign will not unreasonably interfere with the use, enjoyment, or valuation of the property of other persons located within the vicinity of the site, provided that the conditions of approval are adhered to for the life of the project. The sign has been designed to be consistent in design with the other automobile dealership freeway-oriented signs and is conditioned not to cause light and/or glare on adjacent streets and properties.

4. The proposed use will not jeopardize, endanger, or otherwise constitute a menace to public health, safety, or general welfare.

Provided that the sign is constructed as proposed and adheres to the conditions of approval for the life of the project, the proposed sign will not jeopardize, endanger, or otherwise constitute a menace to public health, safety, or general welfare. Conditions of Approval require the sign to be installed per requirements of Caltrans for lighted signs adjacent to freeways and that the sign lighting be directed and shielded so as not to cause light and glare on adjacent properties.

5. That the proposed site is adequate in size and shape to accommodate the yards, walls, fences, parking and loading facilities, landscaping and other development features prescribed in this title or as is otherwise required in order to integrate such use with the uses in the surrounding area.

The proposed project only proposes the installation of a 59-foot high freeway-oriented electronic readerboard sign within ten (10) feet of the freeway right-of-way. The sign can be easily accommodated on-site without negatively impacting on and off-site circulation and has been designed to be consistent in design within other freeway-oriented signs with the automobile dealership area.

6. The proposed site is adequately served by highways or streets of sufficient width and improved as necessary to carry the kind and quantity of traffic to be generated, and by other public or private service facilities as required.

The proposed project only proposes the installation of a freeway-oriented electronic readerboard sign that is located adjacent to the Garden Grove Freeway and Brookhurst Street rights-of-way. The site is adequately served by highways and streets, and the location of the sign will not impede access to and from the site nor will it require any site or street modifications to accommodate the sign.

INCORPORATION OF FACTS AND REASONS SET FORTH IN STAFF REPORT

In addition to the foregoing, the Planning Commission incorporates herein by this reference, the facts and reasons set forth in the staff report.

BE IT FURTHER RESOLVED that the Planning Commission does conclude:

The Conditional Use Permit possesses characteristics that would indicate justification of the request in accordance with Municipal Code Section 9.32.030.

In order to fulfill the purpose and intent of the Municipal Code and thereby promote the health, safety, and general welfare, the attached Conditions of Approval (Exhibit "A") shall apply to Conditional Use Permit No. CUP-347-12.

Conditional Use Permit No. CUP-347-12 shall not become effective until and unless an Ordinance adopted by the City of Garden Grove City Council, approving

an amendment to Planned Unit Development No. PUD-110-96 in substantially the same form as recommended by the Planning Commission becomes effective.

ADOPTED this 1st day of March, 2012

/s/ JENNIFER CABRAL
CHAIR

I HEREBY CERTIFY that the foregoing resolution was duly adopted at the regular meeting of the Planning Commission of the City of Garden Grove, State of California, held on March 1, 2012, by the following votes:

AYES:	COMMISSIONERS:	CABRAL, LAZENBY, SILVA
NOES:	COMMISSIONERS:	BRIETIGAM, PAK
ABSENT:	COMMISSIONERS:	BUI, DOVINH

/s/ JUDITH MOORE
SECRETARY

PLEASE NOTE: Any request for court review of this decision must be filed within 90 days of the date this decision was final (See Code of Civil Procedure Section 1094.6).

A decision becomes final if it is not timely appealed to the City Council. Appeal deadline is March 22, 2012.

EXHIBIT "A"

Conditional Use Permit No. CUP-347-12 9898 Trask Avenue

CONDITIONS OF APPROVAL

GENERAL CONDITIONS

1. The property owner shall record a "Notice of Agreement with Conditions of Approval and Discretionary Permit," as prepared by the City Attorney's Office. Proof of such recordation is required prior to the issuance of building permits. All conditions of approval are required to be adhered to for the life of the project, regardless of property ownership. Any changes of the conditions of approval require approval of the Hearing Body.
2. Conditional Use Permit No. CUP-347-12 shall not become effective until and unless an Ordinance adopted by the City of Garden Grove City Council approving an amendment to Planned Unit Development No. PUD-110-96 in substantially the same form as recommended by the Planning Commission becomes effective. Approval of this Conditional Use Permit shall be contingent upon approval of Planned Unit Development No. PUD-110-96 (Rev. 12) and shall not be construed to mean any waiver of applicable and appropriate zoning regulations or any Federal, State, County and City laws and regulations; and wherein not otherwise specified, all requirements of the City of Garden Grove Municipal Code shall apply.
3. All modifications shall be approved by the Community Development Department. If other than minor changes are proposed, the appropriate entitlements shall be submitted, such as a new application, containing all proposed revisions, shall be required.
4. Any and all correction notice(s) generated through the plan check and/or inspection process is/are hereby incorporated by reference as conditions of approval and shall be fully complied with by the owner, applicant, and all agents thereof.

Community Development Department

5. This approval shall be for the installation of a 59-foot high freeway-oriented electronic readerboard sign in substantial compliance with the approved set of plans submitted with the subject Conditional Use Permit request and the requirements of PUD-110-96 (Rev. 12), except as modified herein.
6. The maximum height of the readerboard sign shall be 59 feet, measured from grade to top of sign.
7. The design of the sign shall be consistent with other Auto Center signs along Trask Avenue and shall include an arched top with "Garden Grove" copy and a grouping of strawberries on a lattice background graphic under the "Garden Grove" copy. The top feature shall be a minimum of eight (8)-feet in height.

FINAL

The entire sign structure, including supports shall be painted blue to match the blue accents on the building. Color samples shall be submitted along with plans submitted for Building permits.

8. The sign illumination, including the LED screen, shall be dimmed to the level of the ambient light level within the area at dusk and shall not cause light and glare on adjacent residential properties, streets, and freeway right-of-way. Maximum output of light during nighttime hours shall not exceed 15 percent. The readerboard images shall maintain one image between the hours of 10:00 p.m. to 7:00 a.m. in order to reduce light and annoyance impacts to the adjacent residential neighborhoods. During all other times the image on the readerboard shall not change less than every 8 seconds.
9. The proposed freeway-oriented electronic readerboard sign shall comply with the Caltrans standards for lighted and readerboard signs that are adjacent to the freeway right-of-way.
10. The applicant shall allow the advertising of community events, as approved by the City Manager. Said advertising shall not exceed ten (10) percent of the overall advertising time the readerboard is changing copy.
11. Hours and days of construction shall be as set forth in the City of Garden Grove's Municipal Code Section 8.47.010, referred to as the Noise Control Ordinance.
12. The applicant and the property owner shall submit signed letters acknowledging receipt of the decision approving Conditional Use Permit No. CUP-347-12, and their agreement with all Conditions of the Approval.
13. The applicant shall, as a condition of project approval, at its sole expense, defend, indemnify and hold harmless the City, its officers, employees, agents and consultants from any claim, action, or proceeding against the City, its officers, agents, employees and/or consultants, which action seeks to set aside, void, annul or otherwise challenge any approval by the City Council, Planning Commission, or other City decision-making body, or City staff action concerning Conditional Use Permit No. CUP-347-12. The applicant shall pay the City's defense costs, including attorney fees and all other litigation related expenses, and shall reimburse the City for court costs, which the City may be required to pay as a result of such defense. The applicant shall further pay any adverse financial award, which may issue against the City including, but not limited to, any award of attorney fees to a party challenging such project approval. The City shall retain the right to select its counsel of choice in any action referred to herein.

Fire Department

The proposed sign shall not encroach into any required fire lane. Adequate emergency vehicle access shall be maintained at all times. All access gates shall be equipped with a Knox rapid entry keyed access system subject to approval of the Garden Grove Fire Department. Manual gates shall have Knox padlocks.

RESOLUTION NO. 5830-14

A RESOLUTION OF THE PLANNING COMMISSION OF THE CITY OF GARDEN GROVE RECOMMENDING THAT THE CITY COUNCIL ADOPT A MITIGATED NEGATIVE DECLARATION AND APPROVE AMENDMENT NO. A-011-2014, AN AMENDMENT TO CHAPTER 20, SECTION 9.20.110 BILLBOARDS, OF TITLE 9 OF THE GARDEN GROVE MUNICIPAL CODE TO ALLOW EXISTING BILLBOARDS THAT ARE PROPOSED TO BE RELOCATED ALONG THE GARDEN GROVE (22) FREEWAY CORRIDOR TO BE CONVERTED TO ELECTRONIC BILLBOARDS, SUBJECT TO SPECIAL STANDARDS.

WHEREAS, the City of Garden Grove has received an application for (1) Code Amendment No. A-011-2014 to amend Chapter 20, Section 9.20.110 Billboards, of Title 9 of the Garden Grove Municipal Code to allow existing billboards that are proposed to be relocated along the Garden Grove (22) Freeway Corridor to be converted to electronic billboards; and (2) Site Plan No. SP-012-2014 for a billboard relocation in accordance with Garden Grove Municipal Code Section 9.20.110 to land located at west end of the Cardinal Circle cul-de-sac, west of Harbor Boulevard, along the south side of the Garden Grove (22) Freeway, at 11615 Cardinal Circle, Assessor's Parcel No. 100-122-01; and

WHEREAS, if Amendment No. A-011-2014 and Site Plan No. SP-012-2014 are approved, it is contemplated that the City Council will also consider approval of a Relocation Agreement pursuant to Business Professions Code Section 5412 pertaining to the removal of three existing billboard structures within the City and the erection and maintenance of the relocated electronic billboard pursuant to Site Plan No. SP-012-2014; and

WHEREAS, Amendment No. A-011-2014, Site Plan No. SP-012-2014, and the Relocation Agreement are collectively referred to herein as the "Project"; and

WHEREAS, pursuant to the California Environmental Quality Act, California Public Resources Code Section 21000 *et seq.* ("CEQA") and CEQA's implementing guidelines, California Code of Regulations, Title 14, Section 15000 *et seq.*, an initial study was prepared and it has been determined that the proposed Project qualifies for a Mitigated Negative Declaration because the proposed Project with the proposed mitigation measures cannot, or will not, have a significant effect on the environment; and

WHEREAS, the Mitigated Negative Declaration with mitigation measures was prepared and circulated in accordance with CEQA and CEQA's implementing guidelines; and

WHEREAS, the Planning Commission of the City of Garden Grove held a duly noticed public hearing on September 18, 2014 and considered all oral and written testimony presented regarding the Project, the initial study, and the Mitigated Negative Declaration.

NOW, THEREFORE, BE IT RESOLVED, FOUND, AND DETERMINED as follows:

1. The Planning Commission has considered the proposed Mitigated Negative Declaration together with comments received during the public review process.
2. The Planning Commission finds on the basis of the whole record before it, including the initial study and comments received, that there is no substantial evidence that the project will have a significant effect on the environment with mitigation measures.
3. The Planning Commission recommends adoption of the Mitigated Negative Declaration to City Council.
4. The record of proceedings on which the Planning Commission's decision is based is located at the City of Garden Grove, 11222 Acacia Parkway, Garden Grove, California. The custodian of record of proceedings is the Director of Community Development.

BE IT FURTHER RESOLVED that the Planning Commission of the City of Garden Grove, in regular session assembled on September 18, 2014, does hereby recommend that the City Council approve Amendment No. A-011-2014.

BE IT FURTHER RESOLVED in the matter of Amendment No. A-011-2014, the Planning Commission of the City of Garden Grove does hereby report as follows:

1. The case was initiated by Clear Channel Outdoor, Inc.
2. The applicant is requesting approval to amend Chapter 20, Section 9.20.110 Billboards, of Title 9 of the Garden Grove Municipal Code to allow existing billboards that are proposed to be relocated along the Garden Grove (22) Freeway Corridor to be converted to electronic billboards.
3. The Community Development Department has prepared a Mitigated Negative Declaration for the Project that (a) concludes that with the appropriate mitigation measures the proposed project cannot, or will not, have a significant adverse effect on the environment, and (b) was prepared and circulated in accordance with applicable law, including CEQA and CEQA's implementing guidelines.
4. Report submitted by City staff was reviewed.
5. Pursuant to legal notice, a public hearing was held on September 18, 2014, and all interested persons were given an opportunity to be heard.
6. The Planning Commission gave due and careful consideration to the matter during its meeting of September 18, 2014; and

BE IT FURTHER RESOLVED, FOUND AND DETERMINED that the facts and reasons supporting the conclusion of the Planning Commission, as required under Municipal Code Sections 9.32.030 are as follows:

FACTS:

Over the past few years, the City had received requests from outdoor advertising (billboard) companies, that own billboards within the City to relocate existing vinyl billboards along the Garden Grove (22) Freeway and convert them to electronic billboards. The construction of new billboards is prohibited in the City of Garden Grove. However, pursuant to Garden Grove Municipal Code Section 9.20.110.B, the owner of an existing billboard located within the City may seek to relocate the existing billboard to a new location within the City by filing an application for a site plan approval with the City. The Planning Commission is empowered to approve, deny, or conditionally approve such a site plan application in accordance the criteria set forth in Section 9.20.110.B.

Billboards are defined by the City Code as a sign identifying a use, facility, or service not conducted on the premises, or a product that is produced, sold or manufactured off-site.

Clear Channel Outdoor, Inc., which owns approximately 12 billboards within the City, has submitted a Code Amendment request to amend Chapter 20, Section 9.20.110 (Billboards), of Title 9 of the Garden Grove Municipal Code to permit the owner of an existing billboard within the City to convert and/or relocate and convert such billboard to an electronic billboard, provided such relocated and/or converted billboard is located within the Garden Grove (22) Freeway corridor and meets specified size, spacing, distance, orientation, illumination, display, and requirements and complies with all applicable Federal and State law.

Specifically, the proposed Amendment would add a new Subsection 9.20.110.D (Electronic Billboards Within the Garden Grove (22) Freeway Corridor) to Section 9.20.110 (Billboards) and make minor related changes to the existing provisions of Section 9.20.110 for purposes of clarification and compatibility with new provisions pertaining to electronic billboards.

The proposed Amendment would define electronic billboards and the Garden Grove (22) Freeway Corridor and provide clarification as to where the relocated/converted billboards can be located along the Garden Grove (22) Freeway, establish distance requirements between electronic billboards and other billboards and residentially zoned property, limit the intensity of light, require the removal of vinyl billboards located elsewhere within the City of Garden Grove, limit the size of electronic billboards, require the applicant to enter into a relocation agreement with the City, and require compliance with State and Federal law requirements.

FINDINGS AND REASONS:

1. The proposed Code Amendment is internally consistent with the goals, policies, and elements of the General Plan.

The proposed Amendment includes amendments to Chapter 20, Section 9.20.110 (Billboards), of Title 9 of the Garden Grove Municipal Code to allow existing billboards that are proposed to be relocated along the Garden Grove (22) Freeway Corridor to be converted to electronic billboards. The General Plan does not contain specific policies pertaining to the relocation/removal of existing billboards or the conversion of them to electronic billboards. However, the General Plan does contain policies that promote the use of appropriate and compatible signage within commercial centers and encourages the development of new sign standards that are up to date with current industry designs. Goal LU-6 of the General Plan Land Use Element calls for the "revitalization of aging, underused or deteriorated commercial corridors, centers, and properties in the City", Policy LU-6.6 provides that the City should "ensure appropriate and compatible signage is provided within commercial centers", and Policy CD-IMP-2D "encourages the development of new sign standards that are up to date with current industry designs". Pursuant to the proposed Code Amendment, an owner seeking to relocate an electronic billboard to the Garden Grove (22) Freeway Corridor will be required to remove at least two existing billboard faces in the City for each converted electronic billboard face installed. The removal of old legal nonconforming billboard signs that are located within established commercial areas, adjacent to residential zones and their relocation to the Garden Grove (22) Freeway Corridor, along with the conversion so the signs to a newer industry standard, will contribute to the overall improvement to the commercial areas and reduce visual blight. Goal LU-4 of the General Plan Land Use Element states that "the City seeks to develop uses that are compatible with one another." Large billboard signs are generally more compatible with commercial/industrial areas adjacent to the Garden Grove (22) Freeway than with the areas in which existing legal non-conforming signs to be removed are located.

2. The proposed Code Amendment will promote the public health, safety, and welfare.

The proposed Amendment to the regulations pertaining to the electronic billboards along the Garden Grove (22) Freeway Corridor make clear and uniform standards for location, size, frequency of copy change, intensity of light, and removal/relocation of existing billboards within the City of Garden Grove. The standards and requirements are consistent with the both State and Federal guidelines that govern off-premise signage and ensure that that the signs do not create nuisances to the public and adjacent properties.

INCORPORATION OF FACTS AND FINDINGS SET FORTH IN STAFF REPORT

In addition to the foregoing, the Planning Commission incorporates herein by this reference, the facts and findings set forth in the staff report.

BE IT FURTHER RESOLVED that the Planning Commission does conclude:

1. The Code Amendment possesses characteristics that would indicate justification of the request in accordance with Municipal Code Section 9.32.030.D (General Plan Amendment/Code Amendment).
2. The Planning Commission recommends that the City Council adopt an Ordinance approving Amendment No. A-011-2014 and amending Garden Grove Municipal Code Section 9.20.110 as follows (deletions shown in strikeout, additions shown in bolded and underlined text).

SECTION 9.20.110: Billboards

A. Prohibition. **Except for relocations of existing billboards and conversion of existing billboards to electronic billboards pursuant to this Section,** ~~No~~ new billboards shall be constructed within City limits.

B. Relocations of Existing Billboards. An owner of an existing billboard located within the City may apply for a billboard relocation subject to the following procedure and criteria:

1. Process. An applicant for a billboard relocation shall file an application for a site plan approval with the city. The Planning Commission shall be empowered to approve, deny, or conditionally approve the site plan application. The Commission shall apply the criteria as set forth in this subpart in making its determination.
 - a. The Planning Commission shall hold a hearing on the matter and provide notice to property owners of the hearing located within three hundred feet of the relocation site.
2. Criteria. The Planning Commission shall apply the following criteria in making its determination on the site plan:
 - a. The structure shall be constructed on two or less steel supports;
 - b. The relocation site shall be at least three hundred feet from any other existing billboard structure, **and shall also comply with the distance requirements set forth in Subsection D.3.e, if applicable;**
 - c. **Except as otherwise provided in Subsection D,** ~~T~~the height of the sign face shall not exceed fifty feet and the display area should not be less than eight feet from the ground;
 - d. The structure shall incorporate aesthetically pleasing architectural elements to the extent feasible so as to promote compatibility with surrounding properties;

- e. The applicant shall present proof of compliance with any applicable State or Federal law requirements relating to billboard signing and freeway location;
 - f. The structure shall not result in an adverse aesthetic or illumination nuisance upon any surrounding residential neighborhood.
3. Findings. The Planning Commission shall make a finding in approving such a request that the construction of the structure will not have an adverse effect on the public health, welfare, and safety of the community.
- C. Publicly Caused Billboard Relocations. Any proposal to relocate an existing billboard structure which relocation is caused by a city and/or redevelopment agency project shall be subject to the following site plan review process:
1. The City Council shall have sole jurisdiction in considering whether such an application should be approved;
 2. The City Council shall hold a site plan review hearing and utilize the same criteria to be used by the planning commission, except that the city council reserves the right to make exceptions to any of the criteria set forth in Subpart B.2(a.)-(d.).
 3. The City Council shall make the finding that the construction of the structure will not adversely affect the public health, welfare and safety of the community.

D. Electronic Billboards Within the Garden Grove (22) Freeway Corridor.

1. For purposes of this Subsection 9.20.020.D, the following terms shall have the following meanings:

- a. **"Billboard" has the same meaning as defined in Subsection 9.20.020.C.**
- b. **"Electronic billboard" means an internally or externally illuminated billboard that utilizes digital message technology capable of instantaneously changing the static message or copy on the sign electronically.**
- c. **"Garden Grove (22) Freeway Corridor" means the area within the city comprised of the land within three hundred (300) feet of either edge of the California State Route 22 Freeway right-of-way.**

- 2. Notwithstanding any other provision of this Code, subject to the discretionary approval of a site plan application pursuant to Subsections 9.20.110.B or C, above, entry into a relocation agreement with the City in accordance with Business and Professions Code Section 5412, and compliance with the additional requirements set forth below, the owner of an existing billboard within the city may convert and/or relocate and convert such billboard to an electronic billboard, provided such relocated and/or converted billboard is located within the Garden Grove (22) Freeway Corridor. Conversion of an existing billboard to an electronic billboard shall be deemed to be a relocation of an existing billboard that is subject to approval of a site plan application pursuant to Subsection 9.20.110.B. Such relocated and/or converted electronic billboards shall be deemed legal non-conforming uses and structures.**
- 3. In addition to such conditions as may be imposed pursuant to approval of a site plan application for a billboard relocation pursuant to Subsections B and/or C, above, electronic billboards shall be subject to the following criteria and conditions:**

 - a. An electronic billboard may only be located within the Garden Grove (22) Freeway Corridor.**
 - b. Electronic billboards shall comply with all applicable location, distance, size, operational, permit or licensing, and/or other requirements or limits imposed by Federal or State law, including, without limitation, the California Outdoor Advertising Act, California Business and Professions Code Section 5200, et. seq., and its implementing regulations, including applicable amendments thereto. To the extent a conflict arises between any provisions of this Section and applicable Federal or State law, State or Federal law shall control.**
 - c. Each sign face of an electronic billboard shall be oriented primarily for viewing from the Garden Grove (22) Freeway and shall be oriented away from any residentially zoned property.**
 - d. No electronic billboard shall be located on or within 350 feet of any residentially zoned property, as measured from the structural support column of the electronic billboard to the property line.**
 - e. No electronic billboard shall be located within 500 feet of any other billboard located on the same side of the**

freeway or within 1,000 feet of any other electronic billboard or on-premise electronic sign located on the same side of the freeway located on the same side of the freeway.

- f. The permitted height of an electronic billboard shall be determined through the site plan review process and shall be limited to the maximum height necessary to ensure adequate visibility of the display from the Garden Grove (22) Freeway. Requested height of an electronic billboard shall be justified through a balloon or flag test, or other similar test, conducted at the applicant's cost. Unless special circumstances necessitate a taller sign, as demonstrated through a balloon or flag test, or other similar test, no electronic billboard shall exceed sixty (60) feet in height, as measured from finished grade to the top of the billboard structure.
- g. The area of each electronic billboard sign face, including framing and trim, shall not exceed 680 square feet.
- h. Electronic billboard displays shall contain still or static messages or images only, and no part of the sign structure or image being displayed may move or present the appearance or optical illusion of movement, or include flashing, blinking, or traveling lighting, the varying of light intensity, or any other means not providing constant illumination. Each static message or image shall be displayed for a minimum of eight (8) consecutive seconds before changing, and the transition or blank screen time between one display message and the next shall not exceed one (1) second.
- i. The maximum intensity of light output produced by an electronic billboard display shall be established in relation to the immediate ambient lighting, and each electronic billboard shall incorporate an automatic light sensing device that will adjust the brightness or intensity of light output as ambient light conditions change. The maximum measurable light output of an electronic billboard shall not exceed 0.3 foot-candles above the ambient light level at any time, as measured using a foot-candle meter at a pre-set distance perpendicular to the display face of the electronic billboard. The pre-set distance for measurement of intensity of light output with a foot-candle meter shall vary depending on the size of the sign face, as follows:

<u>Nominal Sign Face Size</u>	<u>Distance To Be Measured From</u>
<u>12' x 25'</u>	<u>150'</u>
<u>10'-6" x 36'</u>	<u>200'</u>
<u>14' x 48' or Greater</u>	<u>250'</u>

- j. Electronic billboard owners and/or operators shall make space available for the display of emergency messaging in accordance with local, regional, and/or state protocols.
- k. As a condition to approval of the relocation and/or conversion of a billboard to an electronic billboard, the owner of the electronic billboard shall execute a relocation agreement with the City pursuant to California Business and Professions Code Section 5412 on terms approved by the City Council in its sole and absolute discretion. At a minimum, such a relocation agreement shall (i) require the permanent removal of a minimum of two (2) existing billboard faces within the City for each new electronic billboard face erected or installed, (ii) provide for mitigation by the owner of aesthetic and/or other impacts caused by the electronic billboard(s), (iii) require the owner to comply with any and all required mitigation measures, conditions of approval, and applicable provisions of this Section and this Code; (iv) provide for the payment by the owner of applicable fees and costs; (v) require each owner to indemnify, defend and hold harmless the City from any and all claims, lawsuits, awards and judgments, including any reasonable attorney's fees and court costs, that may arise from the approval of the relocation and/or conversion of a billboard to an electronic billboard and/or the removal of other existing billboards, pursuant to this Section or any other provision of the Code, subject to the terms of the agreement; and (vi) require the owner(s)/operator(s) of the electronic billboard to donate up to ten percent (10%) of the total advertising time on the electronic billboard to community events, as requested by the City Manager. Nothing herein shall be construed to require the City enter into such an agreement or to allow the relocation of an existing billboard or the conversion of an existing billboard to an electronic billboard.
- l. The owner of an electronic billboard authorized pursuant to this Section may, at its sole option, remove the digital display unit(s) from the billboard structure at any time, for any reason, and temporarily or permanently replace

such digital display unit(s) with state-of-the-art non-electronic static sign faces of the same or smaller dimensions.

Adopted this 18th day of September, 2014

ATTEST:

/s/ GARY LAZENBY
CHAIR

/s/ TERESA POMEROY
SECRETARY

STATE OF CALIFORNIA)
COUNTY OF ORANGE) SS:
CITY OF GARDEN GROVE)

I, TERESA POMEROY, Secretary of the City of Garden Grove Planning Commission, do hereby certify that the foregoing Resolution was duly adopted by the Planning Commission of the City of Garden Grove, California, at a meeting held on September 18, 2014, by the following vote:

AYES: COMMISSIONERS: (4) ALEJANDRO, LAZENBY, MARGOLIN, SILVA
NOES: COMMISSIONERS: (2) BRIETIGAM, ZAMORA
ABSENT: COMMISSIONERS: (1) NGUYEN

/s/ TERESA POMEROY
SECRETARY

PLEASE NOTE: Any request for court review of this decision must be filed within 90 days of the date this decision was final (See Code of Civil Procedure Section 1094.6).

A decision becomes final if it is not timely appealed to the City Council. Appeal deadline is October 9, 2014.

RESOLUTION NO. 5831-14

A RESOLUTION OF THE PLANNING COMMISSION OF THE CITY OF GARDEN GROVE APPROVING SITE PLAN NO. SP-012-2014 FOR A BILLBOARD RELOCATION TO 11615 CARDINAL CIRCLE, ASSESSOR'S PARCEL NO. 100-122-01.

WHEREAS, the City of Garden Grove has received an application for (1) Code Amendment No. A-011-2014 to amend Chapter 20, Section 9.20.110 Billboards, of Title 9 of the Garden Grove Municipal Code to allow existing billboards that are proposed to be relocated along the Garden Grove (22) Freeway Corridor to be converted to electronic billboards; and (2) Site Plan No. SP-012-2014 for a billboard relocation in accordance with Garden Grove Municipal Code Section 9.20.110 to land located at west end of the Cardinal Circle cul-de-sac, west of Harbor Boulevard, along the south side of the Garden Grove (22) Freeway, at 11615 Cardinal Circle, Assessor's Parcel No. 100-122-01; and

WHEREAS, pursuant to Resolution No. 5830-14, adopted September 18, 2014, the Planning Commission has recommended that the City Council adopt a Mitigated Negative Declaration for the project and approve Code Amendment No. A-011-2014.

NOW THEREFORE, BE IT RESOLVED that the Planning Commission of the City of Garden Grove, in regular session assembled on September 18, 2014, does hereby approve Site Plan No. SP-012-2014, subject to the adoption of a Mitigated Negative Declaration for the project by the Garden Grove City Council, the adoption and effectiveness of an Ordinance by the Garden Grove City Council approving Code Amendment No. A-011-2014 in substantially the same form as recommended by the Planning Commission pursuant to Resolution No. 5830-14, and approval by the City Council of a Relocation Agreement between the City and the Applicant.

BE IT FURTHER RESOLVED in the matter of Site Plan No. SP-012-2014, the Planning Commission of the City of Garden Grove does hereby report as follows:

1. The subject case was initiated by Clear Channel Outdoor, Inc.
2. The applicant requests approval of Site Plan No. SP-012-2014 to relocate three (3) existing billboard structures and convert them into one (1) two-sided electronic billboard located along the Garden Grove (22) Freeway at 11615 Cardinal Circle in the M-1(Limited Industrial) zone.
3. Pursuant to the California Environmental Quality Act (CEQA), Public Resources Code Section 21000 et. seq., and the CEQA guidelines, 14 California Code of Regulations Sec. 15000 et. seq., an initial study was prepared and it has been determined that the proposed project qualifies for a Mitigated Negative Declaration because the proposed project with the proposed mitigation

measures cannot, or will not, have a significant effect on the environment. The Mitigated Negative Declaration with mitigation measures was prepared and circulated in accordance with CEQA and CEQA's implementing guidelines. Pursuant to Resolution No. 5830-14, adopted September 18, 2014, the Planning Commission recommended that the City Council adopt the Mitigated Negative Declaration for the project.

4. The property has a General Plan Land Use designation of Industrial and is currently zoned M-1 (Limited Industrial). The site is currently developed with a multi-tenant industrial development.
5. Existing land use, zoning, and General Plan designation of property in the vicinity of the subject property have been reviewed.
6. Report submitted by City staff was reviewed.
7. Pursuant to a legal notice, a public hearing was held on September 18, 2014, and all interested persons were given an opportunity to be heard.
8. The Planning Commission gave due and careful consideration to the matter during its meeting of September 18, 2014 and considered all oral and written testimony presented regarding the project.

BE IT FURTHER RESOLVED, FOUND AND DETERMINED that the facts and reasons supporting the conclusion of the Planning Commission, as required under Municipal Code Sections 9.12.020 and 9.24.030, are as follows:

FACTS:

The construction of new billboards is prohibited in the City of Garden Grove. However, pursuant to Garden Grove Municipal Code Section 9.20.110.B, the owner of an existing billboard located within the City may seek to relocate the existing billboard to a new location within the City by filing an application for a site plan approval with the City. The Planning Commission is empowered to approve, deny, or conditionally approve such a site plan application in accordance the criteria set forth in Section 9.20.110.B.

The project applicant proposes to permanently remove four (4) existing non-electronic billboard sign faces and associated structures in the City and to construct and operate one (1) new electronic billboard in the City utilizing a state-of-the-art two-sided digital display.

The locations of the existing billboards that will be removed are:

- 9141 Garden Grove Boulevard (single faced sign);

- 8841 Garden Grove Boulevard (single faced sign); and
- 10152 Westminster Avenue (double faced sign).

The proposed new digital billboard will be located on a parcel along the south side of the Garden Grove (22) Freeway. Column placement of the billboard is located at 11615 Cardinal Circle, in the northern side of the parking lot of an industrial site. The site is 2.95 acres in area, and currently developed with a multi-tenant industrial development.

The site has a General Plan Land Use designation of Industrial and is zoned M-1 (Limited Industrial). Surrounding land uses include industrial uses to the south and west, the OCTA right-of-way to the west, and the SR-22 Freeway to the north. There are no adjacent residential areas near the proposed billboard location.

Various federal and state laws and regulations apply to digital signs and billboards located along highways. The proposed new electronic billboard has been sited and designed to comply with all applicable size, spacing, and distance limits imposed by Federal and/or State law. In addition, the sign will be subject to all applicable operational limits and requirements imposed by Federal and/or State law. The applicant will be required to obtain a permit from the California Department of Transportation prior to erecting and operating the proposed electronic billboard.

The application for Site Plan No. SP-012-2014 is being processed in conjunction with Code Amendment No. A-011-2014. On September 18, 2014, the Planning Commission adopted Resolution No. 5830-14, recommending that the City Council approve Amendment No. A-011-2014. Approval of the subject Site Plan No. SP-012-2014 application will not be effective until and unless the City Council adopts an Ordinance approving Amendment No. A-011-2014.

The Garden Grove Municipal Code currently does not permit relocated billboards to be converted to electronic billboards. Amendment No. A-011-2014 would amend Garden Grove Municipal Code Section 9.20.110 to permit the owner of an existing billboard within the City to convert and/or relocate and convert such billboard to an electronic billboard, provided such relocated and/or converted billboard is located within the Garden Grove (22) Freeway corridor and meets specified size, spacing, distance, orientation, illumination, display, and requirements and complies with all applicable Federal and State law. The proposed new electronic billboard has been sited and designed to comply with the development requirements that would be established pursuant to proposed Amendment No. A-011-2014 and would be subject to the operational requirements that would be established pursuant to proposed Amendment No. A-011-2014 for the life of the sign.

In addition, pursuant to proposed Amendment No. A-011-2014, as a condition to approval of the relocation and/or conversion of a billboard to an electronic billboard, the owner of the electronic billboard will be required to enter into a relocation

agreement with the City pursuant to Business Professions Code Section 5412 on terms approved by the City Council, which, among other things, requires the permanent removal of a minimum of two (2) existing billboard faces within the City for each new electronic billboard face erected or installed, provides for mitigation of aesthetic or other impacts by the owner, requires the owner to comply with all required mitigation measures and conditions of approval imposed through the site plan review process, and requires the owner(s)/operator(s) of the electronic billboard to donate up to 10% of the total advertising time on the electronic billboard to community events.

Pursuant to proposed Amendment No. A-11-2014, the permitted height of an electronic billboard within the Garden Grove (22) Freeway Corridor is to be determined through the site plan review process and shall be limited to the maximum height necessary to ensure adequate visibility from the Garden Grove (22) Freeway. The maximum permitted height of such an electronic billboard would be limited to 60 feet, as measured from finished grade to the top of the billboard structure, unless special circumstances necessitate a taller sign, as demonstrated through a balloon or flag test, or other similar test.

In addition to sound attenuation walls located along the freeway, there is an approximately 30-foot differential between the finished grade on which the base of the support structure of the proposed sign is to be located and the grade of the adjacent Garden Grove (22) Freeway. A flag test conducted on August 7, 2014 demonstrated that, due to these and other special circumstances, the minimum height of a sign at the proposed locations necessary to ensure adequate visibility of the displays from the Garden Grove (22) Freeway is approximately 74 feet, as measured from the finished grade on which the base of the support structure will be erected. At this height, the top of the sign would be approximately 44 feet above the grade of the Garden Grove (22) Freeway at the point adjacent to the sign.

FINDINGS AND REASONS:

Site Plan:

1. The Site Plan complies with the spirit and intent of the provisions, conditions and requirements of Title 9 and the General Plan.

Approval of the proposed Site Plan will result in the permanent removal of three (3) existing legal non-conforming billboard structures and four (4) billboard sign faces from commercial corridors and areas in the City and the relocation of a single freeway-oriented sign structure to an industrial property, which is located adjacent to the Garden Grove (22) Freeway, is surrounded by other industrial uses and the OCTA right-of-way, and is not located in proximity to any residential areas or sensitive receptors,

While the General Plan does not specifically contain policies pertaining to the relocation/removal of existing billboards or the conversion of them to electronic billboards, the General Plan does contain policies that promote the use of appropriate and compatible signage in commercial areas and encourages the development of new signs that are up to date with current industry designs. Goal LU-6 of the General Plan Land Use Element calls for the "revitalization of aging, underused or deteriorated commercial corridors, centers, and properties in the City", Policy LU-6.6 provides that the City should "ensure appropriate and compatible signage is provided within commercial centers," and Policy CD-IMP-2D "encourages the development of new sign standards that are up to date with current industry designs. The removal of the existing old legal non-conforming billboards located in established commercial areas, adjacent to residential zones, and their relocation to the Garden Grove (22) Freeway Corridor, along with the conversion of the signs to a new industry standard, will contribute to the overall improvement to these commercial areas, thereby reducing visual blight. Goal LU-4 of the General Plan Land Use Element states that "the City seeks to develop uses that are compatible with one another." Large billboard signs are more compatible with the proposed freeway-adjacent industrial relocation site than with the areas in which the existing legal non-conforming signs to be removed are located.

Although the construction of new billboards in the City is prohibited by Title 9, the relocation of existing billboards within the City is permitted pursuant to site plan approval by Garden Grove Municipal Code Section 9.20.110. The proposed Site Plan is being processing in conjunction with Code Amendment No. A-011-2014. On September 18, 2014, the Planning Commission adopted Resolution No. 5830-14, recommending that the City Council approve Amendment No. A-011-2014. Approval of the subject Site Plan No. SP-012-2014 application will not be effective until and unless the City Council adopts an Ordinance approving Amendment No. A-011-2014. Proposed Amendment No. A-011-2014 would amend Garden Grove Municipal Code Section 9.20.110 to permit the owner of an existing billboard within the City to convert and/or relocate and convert such billboard to an electronic billboard, provided such relocated and/or converted billboard is located within the Garden Grove (22) Freeway corridor and meets specified size, spacing, distance, orientation, illumination, display, and requirements and complies with all applicable federal and state law. The proposed new electronic billboard has been sited and designed to comply with the development requirements that would be established pursuant to proposed Amendment No. A-011-2014 and would be subject to the operational requirements that would be established pursuant to proposed Amendment No. A-011-2014 for the life of the sign. Provided Amendment No. A-011-2014 is approved and becomes effective, the Site Plan and proposed relocated sign will be in full compliance with the provisions and requirements of Title 9.

2. The project will not adversely affect essential on-site facilities such as off-street parking, loading and unloading areas, traffic circulation, and points of vehicular and pedestrian access.

The installation of the proposed billboard structure will require the relocation of one parking space. The parking space will be relocated, thereby maintaining the number of parking spaces that were originally approved for the development. Sufficient parking is provided, and adequate pedestrian access will remain within the project.

3. The project will not adversely affect essential public facilities such as streets and alleys, utilities and drainage channels.

The installation of the proposed billboard structure will not negatively impact the existing public facilities and will not require additional improvements to public facilities to accommodate the sign. The existing streets, utilities and drainage facilities within the area are adequate to accommodate the existing development and proposed billboard structure. The on-site circulation and parking are sufficient for the existing and proposed development.

4. The project will not adversely impact the Public Works Department's ability to perform its required function.

The project has been reviewed by the Public Works Department. The installation of the billboard structure will not require any on or off-site improvements. Therefore, no impact to the Public Work Departments ability to perform is required functions is anticipated.

5. The project is compatible with the physical, functional and visual quality of the neighboring uses and desirable neighborhood characteristics.

The proposed electronic billboard is proposed to be located within an existing industrial area, along the Garden Grove (22) Freeway Corridor. The billboard structure has been designed to comply with all the standards set forth the associated Code Amendment No. A-011-2014 as well as with State and Federal Guidelines for off-premise advertising signs. Provided that that the billboard complies with all City, State, and Federal requirements the billboard will be compatible with the physical, functional and visual quality of the neighboring uses. Additionally, the removal of the three existing billboard structures located within the City will assist in improving the visual and physical quality of neighborhoods they are located in.

6. That through the planning and design of buildings and building placement, the provision of open space, landscaping and other site amenities will attain an attractive environment for the occupants of the property. The project only

involves the removal and relocation of billboard sign structures and does not include the construction of any buildings. The proposed electronic billboard will be located on an industrial site. Accordingly, the project will not impact the attractiveness of the environment of any occupants of the property.

7. Construction of the proposed electronic billboard structure will not have an adverse effect on the public health, welfare, and safety of the community.

The proposed electronic billboard will be located on a 2.95 acre industrially zoned parcel that is located along the south side of the Garden Grove (22) Freeway, is developed with an existing multi-tenant industrial development, and is surrounded by other industrial uses and the OCTA right-of-way. There are no adjacent residential areas or sensitive receptors near the proposed billboard location, and the display surfaces of the proposed billboard will be oriented toward the freeway and away from other properties. The proposed electronic billboard structure has been sited and designed to comply with all applicable development standards, and will be subject to all operational requirements, imposed by Federal and/or State law and to be established pursuant to proposed Amendment No. A-011-2014. These provisions will impose limits and requirements on the size, spacing, distance, orientation, illumination, and display characteristics of the electronic billboard sign in a manner that will minimize the potentially adverse impacts on other land uses and drivers. In addition, approval of the Site Plan has been made subject to Conditions of Approval to further ensure construction and operational impacts are minimized. Further, the applicant and its successors will be required to comply with and implement all mitigation measures identified in the Mitigated Negative Declaration to mitigate potentially significant environmental impacts. Due to special circumstances, the 74-foot height of the proposed electronic billboard sign is the minimum necessary to ensure adequate visibility of the display from the Garden Grove (22) Freeway. The location and orientation of the proposed billboard sign, the requirement that the applicant enter into a relocation agreement with the City, and the required compliance by the applicant and its successors with applicable State and Federal laws, the provisions of the Garden Grove Municipal Code, and the required mitigation measures, will ensure that any potentially adverse light, glare, or aesthetic impacts on surrounding properties are avoided or minimized.

INCORPORATION OF FACTS AND FINDINGS SET FORTH IN THE STAFF REPORT

In addition to the foregoing, the Planning Commission incorporates herein by this reference, the facts and findings set forth in the staff report.

BE IT FURTHER RESOLVED that the Planning Commission does conclude:

1. The Site Plan possesses characteristics that would indicate justification of the request in accordance with Municipal Code Sections 9.24.030 (Site Plan) and 9.20.110 (Billboards).

- 2. In order to fulfill the purpose and intent of the Municipal Code, and, thereby, promote the health, safety, and general welfare, the following Conditions of Approval, attached as "Exhibit A", shall apply to Site Plan No. SP-012-2014.

- 3. Approval of this Site Plan shall be contingent upon the approval of Code Amendment No. A-011-2014 by the Garden Grove City Council. Site Plan No. SP-012-2014 shall not become effective until and unless an Ordinance adopted by the Garden Grove City Council approving Amendment No. A-011-2014 in substantially the same form as recommended by the Planning Commission becomes effective and the City Council approves a Relocation Agreement with the Applicant. In the event that Code Amendment No. A-011-2014 and/or a Relocation Agreement with the Applicant is not approved by the City Council, the City's approval for SP-012-2014 shall be deemed null and void and of no effect.

Adopted this 18th day of September, 2014

ATTEST:

/s/ GARY LAZENBY
CHAIR

/s/ TERESA POMEROY
SECRETARY

STATE OF CALIFORNIA)
COUNTY OF ORANGE) SS:
CITY OF GARDEN GROVE)

I, TERESA POMEROY, Secretary of the City of Garden Grove Planning Commission, do hereby certify that the foregoing Resolution was duly adopted by the Planning Commission of the City of Garden Grove, California, at a meeting held on September 18, 2014, by the following vote:

AYES:	COMMISSIONERS:	(4)	ALEJANDRO, LAZENBY, MARGOLIN, SILVA
NOES:	COMMISSIONERS:	(2)	BRIETIGAM, ZAMORA
ABSENT:	COMMISSIONERS:	(1)	NGUYEN

/s/ TERESA POMEROY
SECRETARY

PLEASE NOTE: Any request for court review of this decision must be filed within 90 days of the date this decision was final (See Code of Civil Procedure Section 1094.6).

A decision becomes final if it is not timely appealed to the City Council. Appeal deadline is October 9, 2014.

EXHIBIT "A"

CONDITIONS OF APPROVAL

For

Site Plan No. SP-012-2014
11615 Cardinal Circle

General Conditions

1. The Applicant and each owner of the property shall execute, and the applicant shall record a "Notice of Agreement with Conditions of Approval and Discretionary Permit Approval," as prepared by the City Attorney's Office, on the property. Proof of such recordation is required within 30 days of this approval.
2. The term "Applicant", as used herein, shall mean and refer to each of the following: the project applicant, Clear Channel Outdoor, Inc., the owner(s) of the property on which the relocated billboard is located, any future tenant of said property operating under this Site Plan approval, and each of their respective successors and assigns.
3. All Conditions of Approval set forth herein shall be binding on and enforceable against the "Applicant" as defined above. All Conditions of Approval are required to be adhered to for the life of the project, regardless of property ownership. Except as otherwise expressly provided in these Conditions of Approval, any changes to the Conditions of Approval require approval by the Planning Commission.
4. Site Plan No. SP-012-2014 shall not become effective until and unless an Ordinance adopted by the Garden Grove City Council approving Amendment No. A-011-2014 in substantially the same form as recommended by the Planning Commission becomes effective and the City Council approves a Billboard Relocation Agreement with the Applicant. In the event that Code Amendment No. A-011-2014 and/or a Billboard Relocation Agreement with the Applicant is not approved by the City Council, the City's approval for SP-012-2014 shall be deemed null and void and of no effect. Approval of this Site Plan shall not be construed to mean any waiver of applicable and appropriate zoning and other regulations. Unless otherwise expressly specified, all other requirements of the Garden Grove Municipal Code shall apply. The Applicant shall obtain and abide by any necessary permits or licenses required to demolish and remove the existing billboards and to erect and operate the proposed electronic billboard structure, in compliance with all applicable laws.

FINAL

5. Minor modifications to the site plan or these Conditions of Approval may be approved by the Community Development Director, in his or her discretion. Proposed modifications to the site plan or to these Conditions of Approval determined by the Community Development Director not to be minor in nature shall be subject to approval of new and/or amended land use entitlements by the Planning Commission or other applicable City hearing body.
6. The approved site plan, elevations and the use of the subject property as represented by the Applicant are integral parts of the decision approving this Site Plan. Before major modifications may be made to the approved plans or use that result in the intensification of the approved use or create impacts that have not been previously addressed, the proper entitlements shall be obtained reflecting such changes.

Building Services Division

7. The billboard structure shall comply with the California Building Standards Code.

Fire Department

8. The proposed sign shall not encroach into any required fire lane. Adequate emergency vehicle access shall be maintained at all times.

Community Development Department

9. This approval shall be for a billboard relocation pursuant to Garden Grove Municipal Code Section 9.20.110.B. Specifically, this approval authorizes the demolition and permanent removal of three existing legal non-conforming billboard structures in the City and the installation of a relocated double-faced freeway oriented electronic billboard sign along the Garden Grove (22) Freeway in compliance with the approved set of plans submitted with the subject Site Plan request and the requirements of Garden Grove Municipal Code Section 9.20.110 (Billboards), as amended pursuant to Amendment No. A-011-2014. The Applicant's rights and obligations regarding maintenance and removal of the relocated billboard structure and sign faces shall be as established in the Relocation Agreement approved by the City Council. This Site Plan approval shall not result in the granting of any rights to the Applicant with respect to maintenance and removal of the relocated billboard than are greater than as established in the Relocation Agreement or possessed with respect to any of the legal non-conforming billboards to be removed pursuant to this Site Plan approval.

10. The maximum height of the billboard sign shall be 74-feet as measured from grade to top of sign. The electronic billboard faces shall not be larger than 14-feet high x 48-feet wide (672 square feet).
11. The design of the sign shall be consistent with the design approved by the Planning Commission and shown on the submitted plans. Color and material samples of the metal cladding shall be submitted to, and approved by, the Planning Division prior to issuance of building permits.
12. The sign faces of the relocated billboard shall be oriented toward the freeway and shall not cause excessive light and glare impacts on the freeway, adjacent streets or adjacent properties. The sign shall comply with all standards, requirements and limits applicable to illumination, light output, and message/image display set forth in Garden Grove Municipal Code Section 9.20.110.
13. The Applicant and the proposed relocated billboard shall comply with all applicable location, distance, size, operational, permit or licensing, and/or other requirements for off-premise electronic signs adjacent to the freeway right-of-way imposed by Federal or State law, including without limitation, the California Outdoor Advertising Act, California Business and Professions Code Section 5200, et. seq., and its implementing regulations, including applicable amendments thereto. To the extent such State or Federal requirements are stricter or more limiting than the requirements imposed pursuant to these Conditions of Approval, the stricter or more limiting State or Federal requirements shall apply. The Applicant shall demonstrate compliance with all applicable State and Federal requirements to the reasonable satisfaction of the Community Development Director prior to issuance of building permits and for as long as the relocated billboard remains in place on the property.
14. The Applicant shall make space available for the display of emergency messaging in accordance with local, regional, and/or state protocols.
15. In accordance with Garden Grove Municipal Code Section 9.20.110.D Applicant's permanent removal of at least four (4) existing billboard sign faces and associated structures located within the City is an express condition to the City's approval of this Site Plan. Pursuant to the Applicant's proposal, three (3) existing billboard structures with a total of four (4) sign faces located within the City of Garden Grove will be permanently removed. The removal of these existing billboard structures shall be completed prior to issuance of building permits for the construction and installation of the proposed relocated electronic billboard sign.

16. The applicant shall enter into a Billboard Relocation Agreement with the City pursuant to Garden Grove Municipal Code Section 9.20.110.D. Said Agreement shall be approved by the City Council and fully executed prior to issuance of building permits for the relocated billboard sign. The schedule of performance for removal of existing billboards and installation/relocation of new electronic billboard, the time frame for Applicant's maintenance and eventual removal of the relocated billboard on the subject property, the implementation of applicable mitigation measures, and the donation of advertising time on the billboard for community events to the City shall be as set forth in the Billboard Relocation Agreement.
17. Permissible hours and days of construction of the proposed electronic billboard and demolition/removal of existing billboards shall be as set forth in the City of Garden Grove's Municipal Code Section 8.47.010, referred to as the Noise Control Ordinance.
18. The Applicant shall fully comply with and implement all mitigation measures identified in the Mitigated Negative Declaration adopted in conjunction with the approval of Site Plan No. SP-012-2014 and Code Amendment No. A-011-2014. Specifically, and without limitation, such mitigation measures include the following:
 - a. The Applicant shall demonstrate compliance with a maximum 0.3 foot candle increase over ambient light at 250 feet from the sign face at all times upon initial start-up through field testing. If subsequent complaints consisting of direct personal impacts are received by the City of Garden Grove, the applicant shall be required to fund follow-up field testing by an independent contractor or City staff trained in the use of a handheld photometer to demonstrate continued compliance and/or to determine the light intensity level that is necessary to reduce the direct personal impacts to a non-nuisance level.
 - b. The electronic billboard shall be installed with sensors which automatically lower light output in accordance with atmospheric conditions (i.e., cloudy or overcast weather). Throughout sign operation, the dimness setting of the LED sign shall be adjusted in real time so it does not exceed the level of illumination identified under Mitigation Measure AE-1.
 - c. The operation of the electronic billboards shall comply with the following at all times:

- No special visual effects that include moving or flashing lights shall accompany the transition between two successive messages, and no special visual effects shall accompany any message display;
 - The minimum display duration time for messages shall be not less than 8 seconds, and the minimum display time between messages shall be not more than 1 second;
 - The minimum font size shall be established for the maximum speed on SR-22 freeway. The font size standard shall be in accordance with the sign industry's best practices formula.
 - Prior to implementing any of the following, the operator shall submit a request and obtain permission from the City: installing, implementing or using any technology that will allow interaction with drivers, vehicles or any device located in vehicles, including, but not limited to, a radio frequency identification device, geographic positions system, or other device.
 - In the event of any failure or combination of failures that affect the digital billboards' luminance, the operator shall impose a default to an output level no higher than 4 percent of the maximum luminance of the billboard. If this cannot be achieved, then the display shall be required to default to an "off" position until the problem can be resolved.
- d. The operator of any digital billboard operated within the City of Garden Grove shall submit, within 30 days following June 30 of each year, a written report regarding operation of each digital billboard during the preceding period of July 1 to June 30. The operator may submit a combined report for all such digital billboards operated by such operator within the City limits. The report shall, when appropriate, identify incidents or facts that relate to specific digital billboards. The report shall be submitted to the Office of the City Manager and the City Attorney, and shall include the following information:
- Status of the operator's license as required by California Business and Professions Code Section 5300 et seq.;
 - Status of the required permit for individual digital billboards, as required by California Business and Professions Code Section 5350 et seq.;
 - Compliance with the California Outdoor Advertising Act, California Business and Professions Code Section 5200 et. seq. and all regulations adopted pursuant to such Act;
 - Compliance with California Vehicle Code Sections 21466.5 and 21467;
 - Compliance with provisions of written agreements between the U.S. Department of Transportation and the California Department of

- Transportation pursuant to the Federal Highway Beautification Act (23 U.S.C. § 131);
- Compliance with mitigation measures and/or conditions of approval adopted as part of the project approval;
 - Each written or oral complaint received by the operator, or conveyed to the operator by any government agency or any other person, regarding operation of digital billboards within the City of Garden Grove;
 - Each malfunction or failure of a digital billboard operated by the operator within the City of Garden Grove, which shall include only those malfunctions or failures that are visible to the naked eye, including reason for the malfunction, duration and confirmation of repair; and
 - Operating status of each digital billboard operated by the operator within the City of Garden Grove, including estimated date of repair and return to normal operation of any digital billboard identified in the report as not operating in normal mode.
- e. During excavation and grading activities, if archaeological resources are discovered the project contractor shall stop all work and shall retain a qualified archaeologist to evaluate the significance of the finding and appropriate course of action. Salvage operation requirements pursuant to Section 15064.5 of the *CEQA Guidelines* shall be followed and the treatment of discovered Native American remains shall comply with State codes and regulations of the Native American Heritage Commission.
19. The Applicant shall, as a condition of project approval, at its sole expense, defend, indemnify and hold harmless the City, its officers, employees, agents and consultants from any claim, action, or proceeding against the City, its officers, agents, employees and/or consultants, which action seeks to set aside, void, annul or otherwise challenge any approval by the City Council, Planning Commission, or other City decision-making body, or City staff action concerning Site Plan No. SP-012-2014 and Amendment No. A-011-2014, as it relates to this project encompassed by Site Plan No. SP-012-2014. The Applicant shall pay the City's defense costs, including reasonable attorney fees and all reasonable other litigation related expenses, and shall reimburse the City for court costs, which the City may be required to pay as a result of such defense. The Applicant shall further pay any adverse financial award, which may issue against the City including, but not limited to, any award of attorney fees to a party making such challenge. The applicant shall retain the right to select its counsel of choice in any action referred to herein, which shall be reasonably satisfactory to the City. In the event that any third party brings any challenge, the City shall give sufficiently prompt notice to the

Applicant of such challenge and shall in all events give such notice within 10 days of the date that the Office of the City Attorney first learns of the challenge. Notwithstanding the foregoing, in the event any legal action or proceeding is filed against the City and/or applicant, seeking to attack, set aside, void or annul any of Site Plan No. SP-012-2014 or Amendment No. A-011-2014, as it relates to the project encompassed by Site Plan No. SP-012-2014, applicant shall have the right and obligation to either: (1) defend the City with legal counsel selected by the applicant and reasonably satisfactory to the office of the City Attorney; or (2) request that the City rescind Site Plan No. SP-012-2014 approval and Amendment No. A-011-2014, in which case the applicant would have no obligation to defend or indemnify the City and no obligation to make any payments described above; however, applicant shall reimburse the City for any costs incurred or assessed against the City as a result of the filing of such legal action or proceeding, provided the City acts promptly to rescind Site Plan No. SP-012-2014 approval and Amendment No. A-011-2014. The City will not voluntarily assist in any such third-party challenge or take any position adverse to the Applicant in connection with such third party challenge.

MAKENA SQUARE

SIGN CRITERIA

SEPTEMBER 11, 2006

*(TNT Sign)
Revised w/ Bill Henigerson's
Approval 1/15/07*

Sign Project Location

13411 EUCLID ST.
GARDEN GROVE, CA



3080 E. 29TH Street, Long Beach, CA 90806

Bus: (800) 655-6366 • (562) 595-7725

Fax: (562) 595-5434

Website: www.intelelectricsign.com • Email: tntheonsign@aol.com

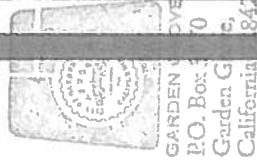

LAND USE
APPROVED

BY: *Fair Jobb*
ON: *10/6/06*
PUD-108-05/
SP-375-05



CA Lic. # C45-629097
AZ Lic # L38-ROC170223

3080 East 29th Street, Long Beach, CA 90806 • Bus: (800) 655-6366 • (562) 595-7725 / Fax: (562) 595-5434

Tenant Sign Criteria

Makena Square Center
13411 Euclid Avenue
Garden Grove, California 92843

Project Directory:

Owner: Makena Great American Company
1450 El Camino Real, 2nd Floor
Tustin, California 92780
(714)505-7611 Fax (714)505-7619

Contact: Brett G. Blanchard

Email Address: brett@makenacapital.net

Sign Consultant: TNT Electric Sign, Inc.

3080 East 29th Street
Long Beach, California 90806-2317
(562)595-7725 Fax (562)595-5434

Contact: Bill Henigsmann

Email Address: ntneonsign@aol.com

City Planning: City of Garden Grove

Community Development Department and
Building & Safety Department
11222 Acacia Parkway
Garden Grove, California 92784
(714)741-5121

Contact: Aaron Webb

Email Address:

Table of Contents

- Pg. 1 Submittals & Approvals
- Pg. 2 General Requirements
- Pg. 3 General Specifications
- Pg. 4 Design Guidelines
- Pg. 5 Monument Sign
- Pg. 6 Miscellaneous Requirements
- Pg. 7 Exceptions

Tenant Sign Criteria
Makena Square
13411 Euclid Avenue
Garden Grove, California 92784

This sign criteria program has been established for the purpose of assuring a first class retail center for the mutual benefit of all Tenants. Conformance will be strictly enforced. Any installation of non-conforming or unapproved signs shall be brought into conformance at the expense of the non-conforming Tenant. There will be a formal approval process for the creation, review and approval of all Tenant signs at Makena Square Center. All Tenant Signage is subject to the Landlord's/Owner's or Landlord's/Owner's managing agent written approval and will be granted based on the Following:

SUBMITTALS & APPROVALS

1. Design, fabrication and method of installation of all signs shall conform to this sign program.
2. Proposed signage is in harmony with adjacent signage conditions and conforms within the design standards.

A. SUBMITTAL TO OWNER:

1. Each Tenant shall submit to the owner, drawings to be reviewed for conformance with this sign criteria and overall design quality. Approval or disapproval of sign submittals based on aesthetics of design shall remain the sole right of the Landlord/Owner.
2. Each Tenant shall submit for approval, in the Landlord's/Owner's sole and absolute discretion, before fabrication at least three (3) copies of detailed shop drawings on an eleven inches by seventeen inches (11" x 17") sheets indicating the location, size, design layout and colors of the proposed signs, including all lettering and/or graphics to Landlord/Owner for approval prior to city submittal for review and approval. Sign drawings are to be prepared by a California licensed sign contractor. All signs must conform to the city requirements of the City of Garden Grove Planning and Building Department.

B. GENERAL REQUIREMENTS

1. All permits for signs and their installation shall be obtained and comply with local planning, building and electrical codes. These permits shall be obtained by Tenant or Tenant's representative prior to installation. A full set of plans must be approved and stamped by the Landlord/Owner prior to permit application.
2. Tenant's sign contractor must submit to the City of Garden Grove and will be responsible for all applicable applications required for city approvals and permit fees for the Planning and Building departments.
3. No exposed lamps, raceways, crossovers, conduits, conductors, transformers or similar devices shall be permitted.
4. All Tenants must have installed approved signs before opening for business.
5. Any damage to the building fascia or sign area resulting from the installation or removal of any sign by Tenant will be repaired by the Landlord/Owner at the Tenant's expense.
6. All signs shall meet U.L. specifications.
7. Tenants shall be responsible for the fulfillment of all the requirements and specifications set forth in this sign criteria.

C. GENERAL SPECIFICATIONS

1. Tenant's sign contractor shall have a class C-45 state contractor license and be insured by an admitted insurance carrier for the total aggregate amount of One Million Dollars (\$1,000,000.00) and provide proof of insurance acceptable to the Landlord/Owner and that the Landlord/Owner is named as an additional insured on the certificate of insurance.
2. Tenant shall be responsible for the installation and maintenance of its sign.
3. Tenant shall be fully responsible for the operations of the Tenant's sign contractor.
4. Tenant's sign contractor shall repair under Landlord's/Owner's supervision, any damage caused by installation.
5. Electrical service to all signs will be connected to the Tenant's electrical meter.
6. No labels will be permitted on the exposed surface of signs, except those required by local ordinance which shall be placed in an inconspicuous location.
7. Design, layout and materials for Tenants signs shall conform in all respects with the sign design drawings included with this sign criteria.
8. All penetrations of building structure required for sign installation shall be sealed in a watertight condition and shall be patched to match adjacent building finish.
9. Each Tenant shall be allowed one (1) set of channel letters and one (1) logo per elevation and not to exceed the allowable signage square footage. All signs must face a street or parking lot.
10. Sign area will be formulated by one square foot (1 Sq. Ft.) of the sign area per each lineal front of foot of store frontage not to exceed the sixty square feet (60 Sq. Ft.) of the sign area per elevation.

E. MONUMENT SIGN

1. Multi-Tenant retail building to be allowed one (1) monument sign.
2. Sign to be four feet (4'0") in overall height.
3. Cabinet, columns and base to be fabricated from .063 aluminum or greater.
4. Aluminum to be tex-coat work and painted to match adjacent building.
5. Tenant faces may be 3/16" thick white lexan with a vinyl overlay for copy and graphics.
6. Tenant copy to be approved by the Landlord/Owner before fabrication.
7. Tenant copy will be a minimum of 7 1/2" high.
8. Three (3) tenants will be allowed on monument only along with name of center.

F. MICELLANEOUS REQUIREMENTS

1. Each Tenant shall be permitted to place upon each entrance of its premises, not more than one-hundred forty-four square inches (144 Sq. Inches) of white vinyl overlay lettering not to exceed two inches (2") in height, indicating hours of business, emergency telephone numbers and other similar identification. Approved font style is Humnst 777 BT.
2. Twelve inches high (12") in height white vinyl suite numbers will be allowed per each Tenant.
3. Except as provided herein, no advertising placards, banners, pennants, names, insignia trademarks or other descriptive signs or materials shall be affixed or maintained upon the glass pane supports of the exterior walls of the building, without the prior written approval of the Landlord/Owner and the City of Garden Grove.
4. No animated, flashing or audible signs will be permitted.
5. **Immoral or Unlawful Advertising:**
Tenant shall not exhibit, post or display upon any sign, anything of an obscene, indecent or immoral nature or unlawful activity.
6. **Vehicle Sign:**
Signs on or affixed to trucks, truck beds, automobiles, trailers or any other vehicles which advertise, identify or provide direction to use or activity not related to its lawful making of deliveries of sales or merchandise or rendering of services from such vehicles, is prohibited.
7. The entire display shall be guaranteed for one year against defects in materials and workmanship. Defective parts shall be replaced without charge.
8. Any signs not conformance with these rules and all governmental regulations will be rejected and removed at the Tenant's expense.
9. Tenant signs installed without approval from the Landlord/Owner, the City of Garden Grove and/ or the insurance of building permits may be cited by code enforcement.

G. EXCEPTIONS

Exceptions to the above may be submitted for review to the City of Garden Grove. Before any such submittal, all changes must be approved by the Landlord/Owner.

Sign Criteria prepared by: TNT Electric Sign, Inc.
3080 East 29th Street
Long Beach, California 90806-2317
(562)595-7725 Fax (562)595-5434

Contact: Bill Henigsman
Email Address: tntneonsign@aol.com

MAKENA SQUARE

EXHIBIT 1

TENANT SIGNAGE LOCATION

NOTE: COPY SHOWN ON BUILDING ELEVATION IS FOR ILLUSTRATION PURPOSES ONLY. COPY DOES NOT DEPICT ACTUAL TENANT OR TENANTS COPY.

1. INTERNALLY ILLUMINATED CHANNEL LETTERS, OPEN FACE CHANNEL LETTERS, HALO LETTERS OR DUAL LITE LETTERS.
2. LETTERS TO BE FABRICATED FROM ALUMINUM OR SHEET METAL PAINTED WITH MATTHEWS POLYURETHANE FINISH OVER PROTECTIVE PRIMER UNDERCOAT.
3. FACES TO BE 3/16" THICK WHITE ACRYLIC PLASTIC WITH VINYL OVERLAY.
4. TENANT COLOR TO BE DETERMINED.
5. TRIM CAPS TO BE 3/4" THICK PAINTED TO MATCH COLOR OF FACE OR ANY COLOR APPROVED BY LANDLORD. NO GOLD TRIM CAP.
6. RETURNS TO BE 5" THICK PAINTED TO MATCH COLOR OF BUILDING OR ANY COLOR APPROVED BY LANDLORD.
7. ALL COMPONENTS TO BE U.L. LISTED.
8. MAXIMUM LETTER HEIGHT NOT TO EXCEED 18".
9. NO RACEWAYS ARE ALLOWED.

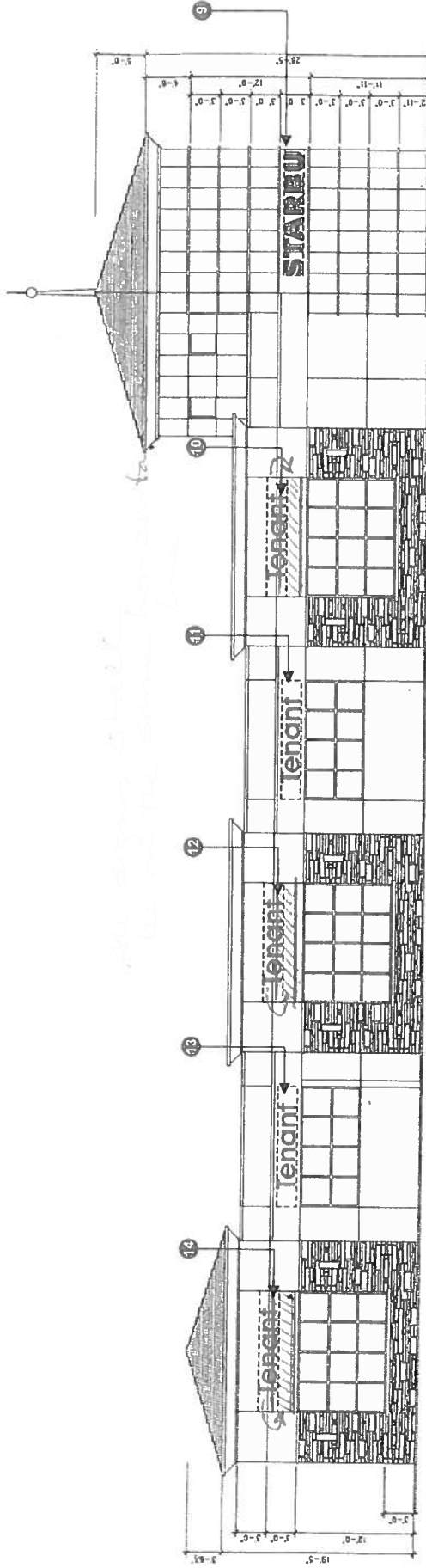

MAKENA SQUARE SOUTH ELEVATION

SCALE: 1/16" = 1'-0"

MAKENA SQUARE

EXHIBIT 2

TENANT SIGNAGE LOCATION

1. INTERNALLY ILLUMINATED CHANNEL LETTERS, OPEN FACE CHANNEL LETTERS, HALO LETTERS OR DUAL LITE LETTERS.
2. LETTERS TO BE FABRICATED FROM ALUMINUM OR SHEET METAL PAINTED WITH MATTHEWS POLYURETHANE FINISH OVER PROTECTIVE PRIMER UNDERCOAT.
3. FACES TO BE 3/16" THICK WHITE ACRYLIC PLASTIC WITH VINYL OVERLAY.
4. TENANT COLOR TO BE DETERMINED.
5. TRIM CAPS TO BE 3/4" THICK PAINTED TO MATCH COLOR OF FACE OR ANY COLOR APPROVED BY LANDLORD. NO GOLD TRIM CAP.
6. RETURNS TO BE 5" THICK PAINTED TO MATCH COLOR OF BUILDING OR ANY COLOR APPROVED BY LANDLORD.
7. ALL COMPONENTS TO BE UL LISTED.
8. MAXIMUM LETTER HEIGHT NOT TO EXCEED 18".
9. NO RACEWAYS ARE ALLOWED.

NOTE: COPY SHOWN ON BUILDING ELEVATION IS FOR ILLUSTRATION PURPOSES ONLY. COPY DOES NOT DEPICT ACTUAL TENANT OR TENANTS COPY.

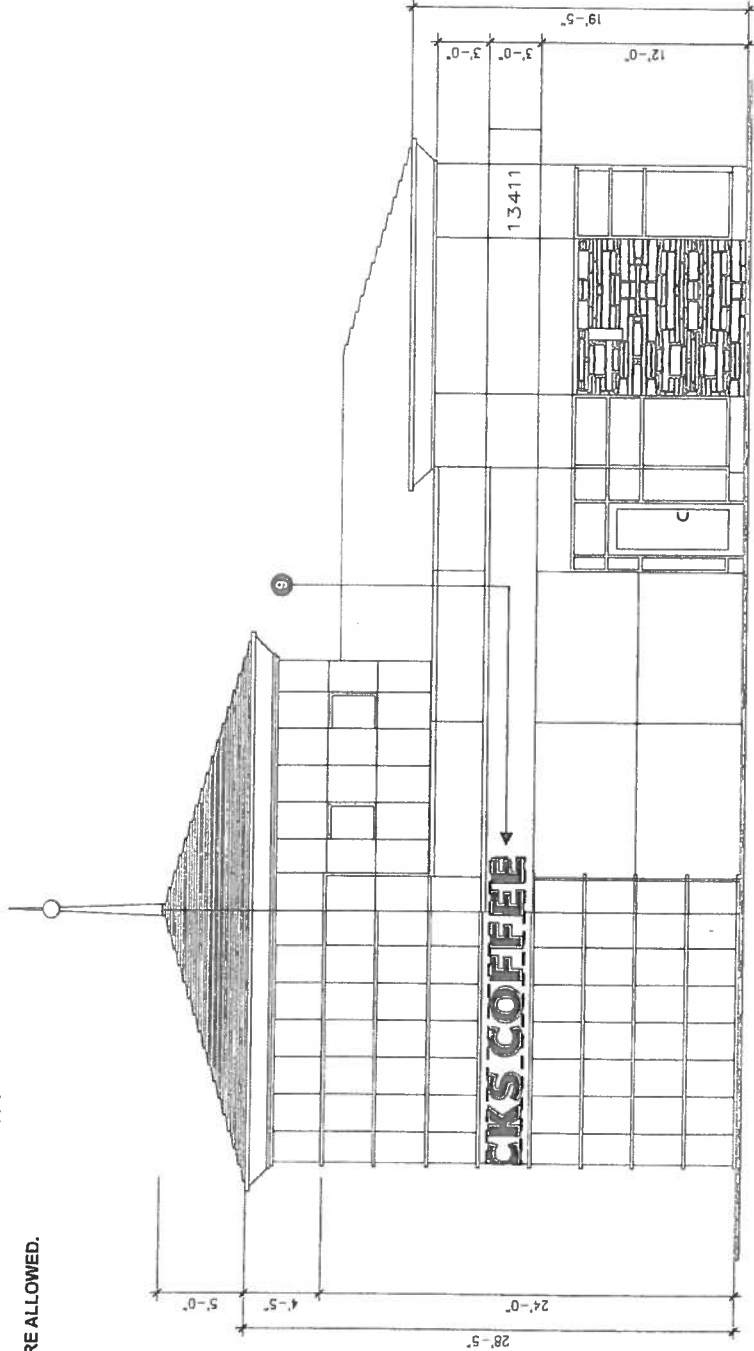

MAKENA SQUARE EAST ELEVATION

SCALE: 3/32" = 1'-0"

MAKENA SQUARE

EXHIBIT 3

TENANT SIGNAGE LOCATION

1. INTERNALLY ILLUMINATED CHANNEL LETTERS, OPEN FACE CHANNEL LETTERS, HALO LETTERS OR DUAL LITE LETTERS.
2. LETTERS TO BE FABRICATED FROM ALUMINUM OR SHEET METAL PAINTED WITH MATTHEWS POLYURETHANE FINISH OVER PROTECTIVE PRIMER UNDERCOAT.
3. FACES TO BE 3/16" THICK WHITE ACRYLIC PLASTIC WITH VINYL OVERLAY.
4. TENANT COLOR TO BE DETERMINED.
5. TRIM CAPS TO BE 3/4" THICK PAINTED TO MATCH COLOR OF FACE OR ANY COLOR APPROVED BY LANDLORD. NO GOLD TRIM CAP.
6. RETURNS TO BE 5" THICK PAINTED TO MATCH COLOR OF BUILDING OR ANY COLOR APPROVED BY LANDLORD.
7. ALL COMPONENTS TO BE UL LISTED.
8. MAXIMUM LETTER HEIGHT NOT TO EXCEED 18".
9. NO RACEWAYS ARE ALLOWED.

LOGO SIGN

1. LOGO SIGN IS INTERNALLY ILLUMINATED WITH 6500 WHITE NEON.
2. LOGO TO BE FABRICATED FROM ALUMINUM OR SHEET METAL PAINTED WITH MATTHEWS POLYURETHANE FINISH OVER PROTECTIVE PRIMER UNDERCOAT.
3. FACES TO BE 3/16" THICK WHITE LEXAN OR ACRYLIC PLASTIC FACES WITH VINYL OVERLAY FOR COPY & GRAPHICS.
4. TENANT COLOR TO BE DETERMINED.
6. RETURN TO BE PAINTED TO MATCH COLOR OF BUILDING OR ANY COLOR APPROVED BY LANDLORD.
7. ALL COMPONENTS TO BE UL LISTED.
8. MAXIMUM LOGO HEIGHT NOT TO EXCEED 48".
8. NO RACEWAYS ARE ALLOWED.

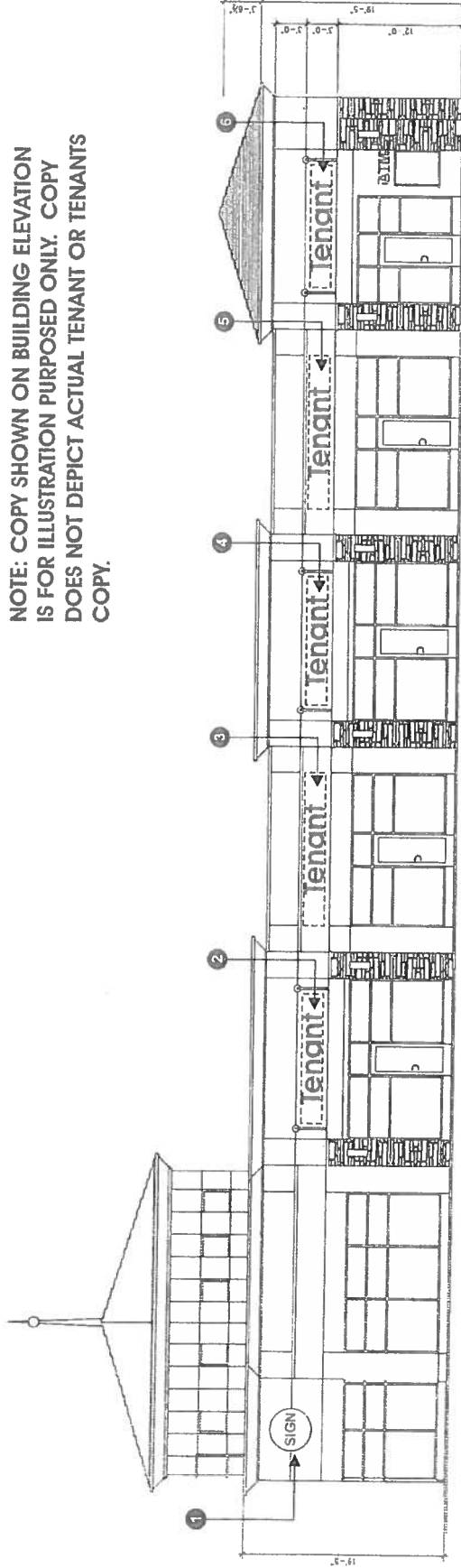

MAKENA SQUARE NORTH ELEVATION

SCALE: 1/16" = 1'-0"

MAKENA SQUARE

EXHIBIT 4

TENANT SIGNAGE LOCATION

1. INTERNALLY ILLUMINATED CHANNEL LETTERS, OPEN FACE CHANNEL LETTERS, HALO LETTERS OR DUAL LITE LETTERS.
2. LETTERS TO BE FABRICATED FROM ALUMINUM OR SHEET METAL PAINTED WITH MATTHEWS POLYURETHANE FINISH OVER PROTECTIVE PRIMER UNDERCOAT.
3. FACES TO BE 3/16" THICK WHITE ACRYLIC PLASTIC WITH VINYL OVERLAY.
4. TENANT COLOR TO BE DETERMINED.
5. TRIM CAPS TO BE 3/4" THICK PAINTED TO MATCH COLOR OF FACE OR ANY COLOR APPROVED BY LANDLORD. NO GOLD TRIM CAP.
6. RETURNS TO BE 5" THICK PAINTED TO MATCH COLOR OF BUILDING OR ANY COLOR APPROVED BY LANDLORD.
7. ALL COMPONENTS TO BE UL LISTED.
8. MAXIMUM LETTER HEIGHT NOT TO EXCEED 18".
9. NO RACEWAYS ARE ALLOWED.

NOTE: COPY SHOWN ON BUILDING ELEVATION IS FOR ILLUSTRATION PURPOSES ONLY. COPY DOES NOT DEPICT ACTUAL TENANT OR TENANTS COPY.

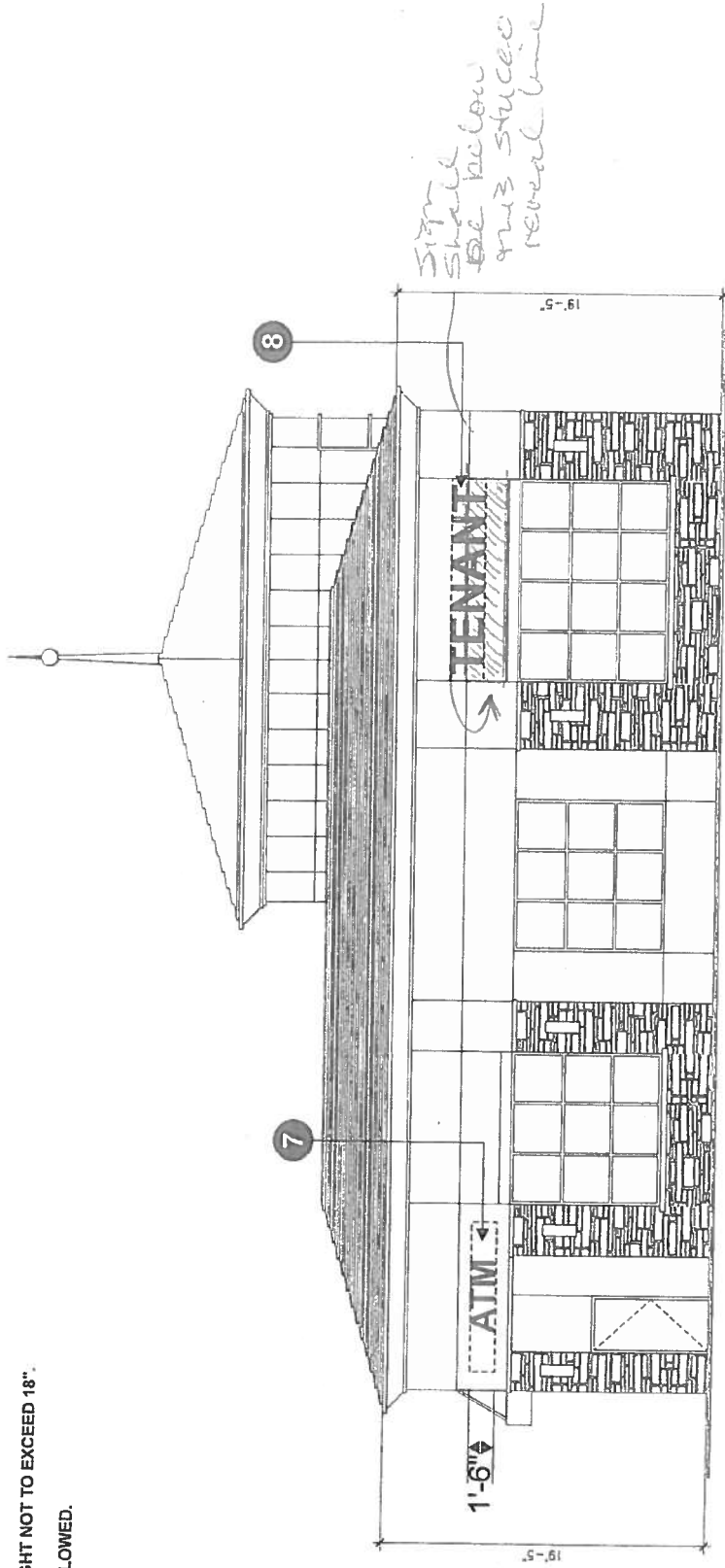

MAKENA SQUARE WEST ELEVATION

SCALE: 3/32" = 1'-0"

MAKENA SQUARE

EXHIBIT 5

TENANT SIGNAGE LOCATION

1. DOUBLE FACE INTERNALLY ILLUMINATED MONUMENT SIGN
2. CABINET TO BE FABRICATED FROM ALUMINIUM OR SHEET METAL PAINTED WITH MATTHEW'S POLYURETHANE FINISH OVER PROTECTIVE PRIMER UNDERCOAT.
3. PANEL FACES TO BE 3/16" THICK WHITE LEXAN W/ 1ST SURFACE VINYL OVERLAY.
4. TENANT COLOR TO BE DETERMINED.
5. CABINET TO BE PAINTED TO MATCH BUILDING. TOP STRUCTURE & BOTTOM OF CABINET TO BE ALUMINIUM W/ STUCCOED APPLIED OVER. STUCCO TO MATCH BUILDING.
6. ALL COMPONENTS TO BE UL LISTED.

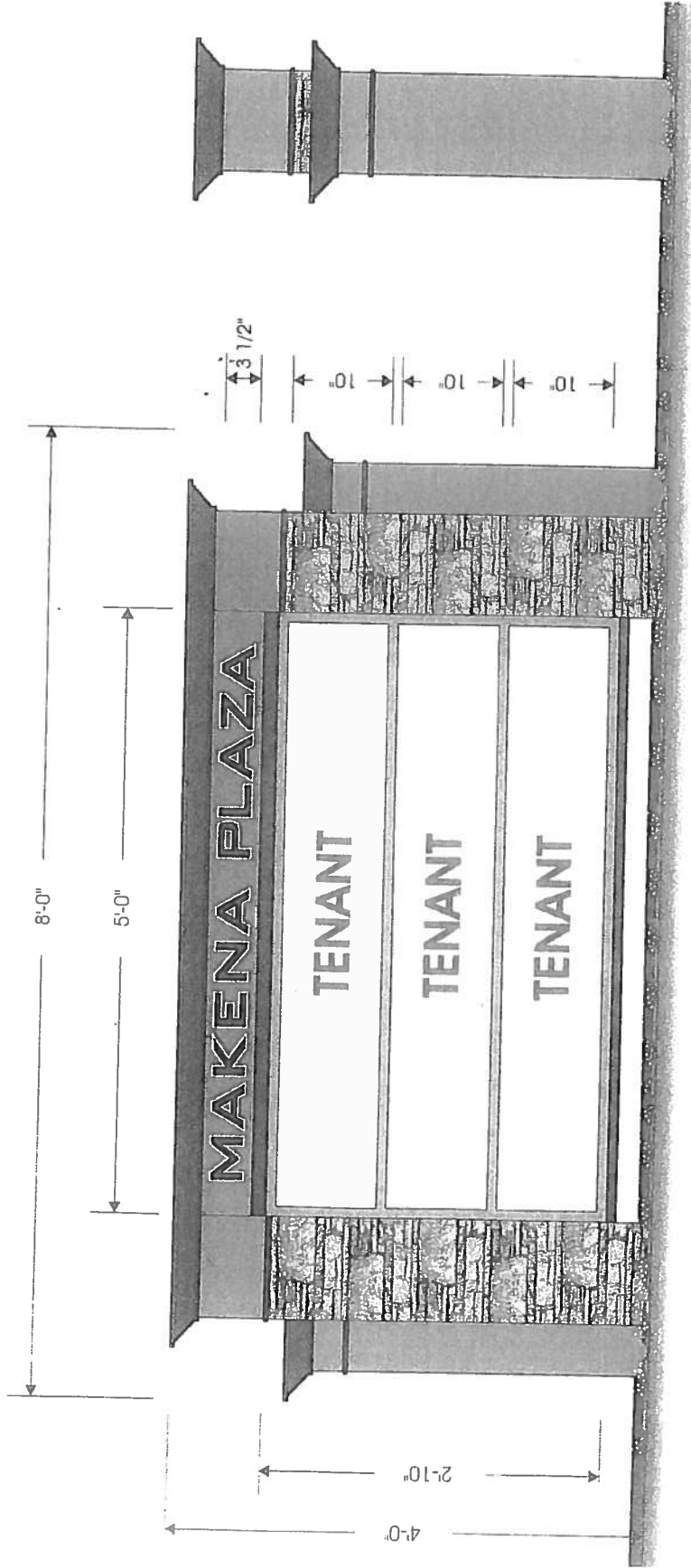

MAKENA SQUARE MONUMENT SIGN

SCALE: 3/4" = 1'-0"

MAKENA SQUARE

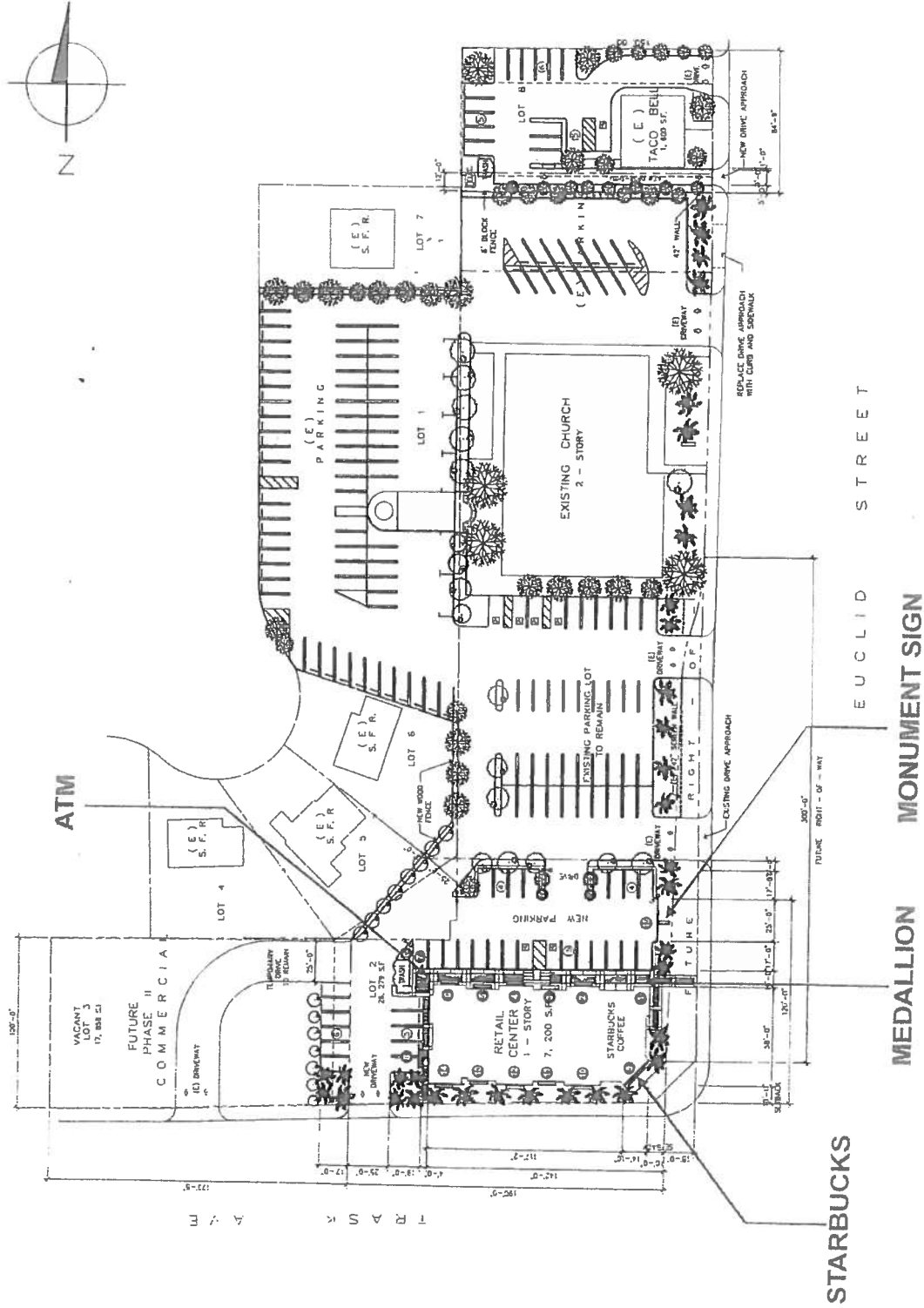

MAKENA SQUARE SITE PLAN

SCALE: NOT TO SCALE

MAKENA SQUARE

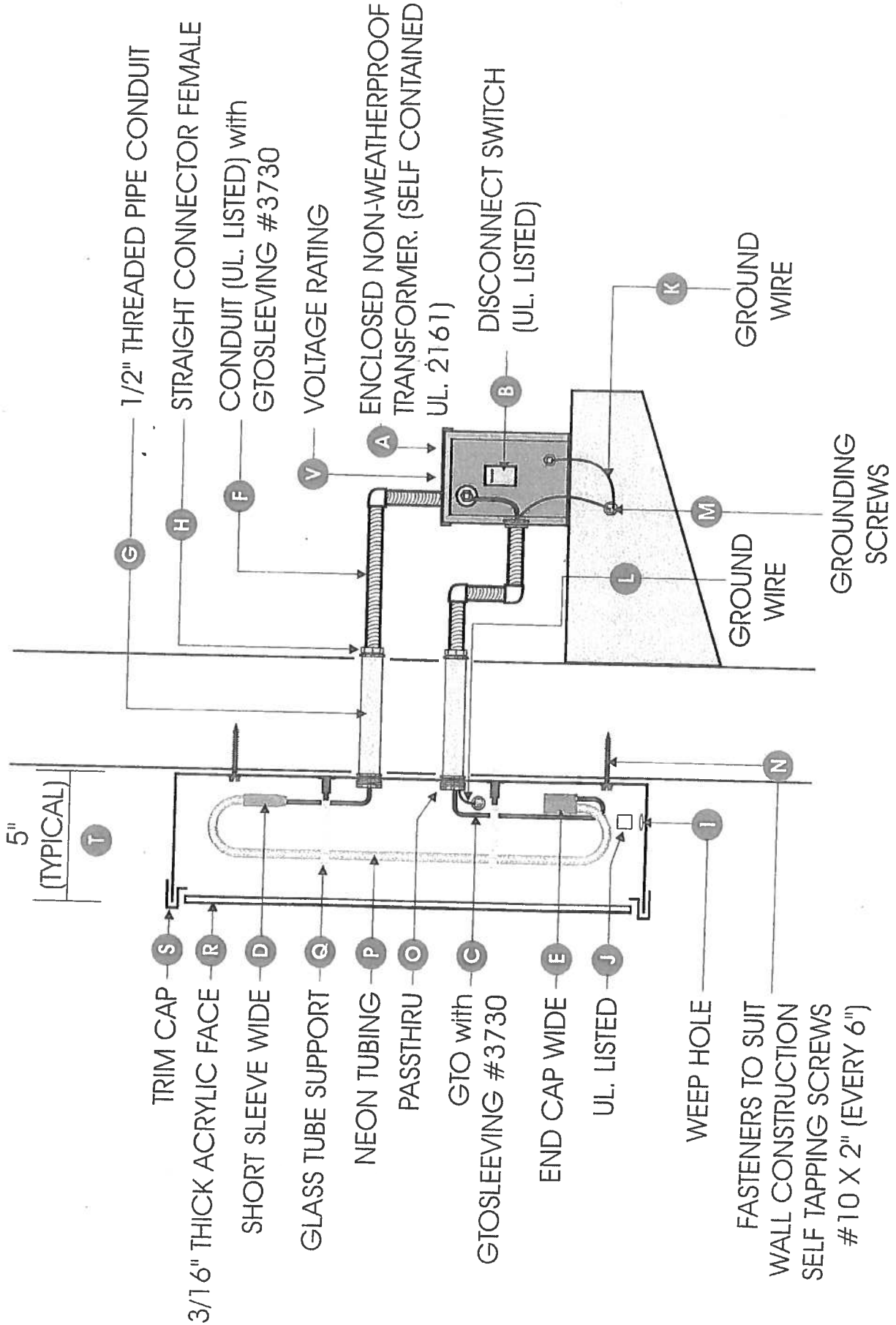

MAKENA SQUARE WALL MOUNTED CHANNEL LETTERS DETAILS

SCALE: NOT TO SCALE

Subject: Re: Site "C" Update

From: Matthew Reid <Matt.reid@landanddesign.com>

Date: Thu, 24 Sep 2015 17:10:12 -0700

To: Maria Parra <mariap@ci.garden-grove.ca.us>

CC: David Rose <drose3@charter.net>, Khan Ziad <zkhan@langdonwilson.com>, Lee Marino <leem@ci.garden-grove.ca.us>, Karl Hill <karlh@ci.garden-grove.ca.us>, Jane Chang <jane.chang@aecom.com>, Greg Blodgett <gregl@ci.garden-grove.ca.us>

Thank you!!

Sent from my iPhone

Matthew Reid

Land & Design, Inc.

3755 Avocado Blvd | #516 | LaMesa, CA 91942

858.735.1858 cell

Skype - matthew.reid.ca

matt.reid@landanddesign.com

Check out our new website www.landanddesign.com

On Sep 24, 2015, at 3:30 PM, Maria Parra <mariap@ci.garden-grove.ca.us> wrote:

Hi Matt,

Attached are the approvals for the Hyundai reader board, and the Clear Channel billboard signs.

Also attached is a sample sign program and the Harbor Blvd sign criteria. At your earliest convenience, please submit a revised sign plan that shows the placement of all proposed signage with dimensions, including all individual channel letters and reader boards. The placement of the signs on the building, especially the reader boards, must reflect the worst case scenario. Ziad mentioned that he has a copy of the reader board sign criteria from the City of Los Angeles, please e-mail a copy of the document to me.

Also, below is a list of some of the concerns that Planning Commissioners and residents have raised about reader boards. It's important that your team be prepared to address each point both in the environmental document and at the Public Hearing:

- reader board light output
- angle of light dispersion
- motion/ movement
- image change time
- dimming during certain night hours
- documentation on safety for non-freeway reader boards
- reader board impacts to local street traffic

Best regards,

Maria Parra

Urban Planner

City of Garden Grove | Planning Services Division

11222 Acacia Parkway, Garden Grove, CA 92840
(714) 741-5312 | (714) 741-5578 fax

mariap@ci.garden-grove.ca.us | www.ci.garden-grove.ca.us

Community Development Department of the City of Garden Grove
"Providing Quality Services Through Creativity and Collaboration"

City Hall Hours:

Monday-Thursday: 7:30 a.m. to 5:30 p.m.

First Friday of the Month: 7:30 a.m. to 5:00 p.m.

Direct Website Links:

[Planning Division](#)

[Municipal Code, Title 9, Land Use](#)

[Zoning Map](#)

<harbor signage.pdf>

<201509241420.pdf>

Subject: Re: Site "C" Update
From: Greg Blodgett <greg1@ci.garden-grove.ca.us>
Date: Thu, 24 Sep 2015 17:55:41 -0700 (PDT)
To: Matthew Reid <Matt.reid@landanddesign.com>

Thanks

Sent from my iPhone

On Sep 24, 2015, at 5:14 PM, Matthew Reid <Matt.reid@landanddesign.com> wrote:

Thank you!!

Sent from my iPhone

Matthew Reid

Land & Design, Inc.

3755 Avocado Blvd | #516 | LaMesa, CA 91942

858.735.1858 cell

Skype - [matthew.reid.ca](https://www.skype.com/people/matthew.reid.ca)

matt.reid@landanddesign.com

Check out our new website www.landanddesign.com

On Sep 24, 2015, at 3:30 PM, Maria Parra <mariap@ci.garden-grove.ca.us> wrote:

Hi Matt,

Attached are the approvals for the Hyundai reader board, and the Clear Channel billboard signs.

Also attached is a sample sign program and the Harbor Blvd sign criteria. At your earliest convenience, please submit a revised sign plan that shows the placement of all proposed signage with dimensions, including all individual channel letters and reader boards. The placement of the signs on the building, especially the reader boards, must reflect the worst case scenario. Ziad mentioned that he has a copy of the reader board sign criteria from the City of Los Angeles, please e-mail a copy of the document to me.

Also, below is a list of some of the concerns that Planning Commissioners and residents have raised about reader boards. It's important that your team be prepared to address each point both in the environmental document and at the Public Hearing:

- reader board light output
- angle of light dispersion
- motion/ movement
- image change time
- dimming during certain night hours
- documentation on safety for non-freeway reader boards
- reader board impacts to local street traffic

Best regards,

Maria Parra

Urban Planner

City of Garden Grove | Planning Services Division

11222 Acacia Parkway, Garden Grove, CA 92840
(714) 741-5312 | (714) 741-5578 fax

mariap@ci.garden-grove.ca.us | www.ci.garden-grove.ca.us

Community Development Department of the City of Garden Grove
"Providing Quality Services Through Creativity and Collaboration"

City Hall Hours:

Monday-Thursday: 7:30 a.m. to 5:30 p.m.

First Friday of the Month: 7:30 a.m. to 5:00 p.m.

Direct Website Links:

[Planning Division](#)

[Municipal Code, Title 9, Land Use](#)

[Zoning Map](#)

<harbor signage.pdf>

<201509241420.pdf>

From: Greg Blodgett <greg1@ci.garden-grove.ca.us>

Date: Tue, 29 Sep 2015 10:34:21 -0700 (PDT)

To: Matthew Reid <matt.reid@landanddesign.com>

Can we call you re site c dof at 11.30

We have a conf call with dof at 1.30 and would like to have you on the call

Sent from my iPhone

Re:

Subject: Re:

From: Matthew Reid <matt.reid@landanddesign.com>

Date: Tue, 29 Sep 2015 10:43:57 -0700

To: Greg Blodgett <greg1@ci.garden-grove.ca.us>

I'm jammed with meetings today from 11am - 6pm tonight.

Matthew Reid

Land & Design, Inc.

3755 Avocado Blvd | #516 | LaMesa, CA 91942

858.735.1858 cell

Skype - [matthew.reid.ca](https://www.skype.com/user/matthew.reid.ca)

matt.reid@landanddesign.com

Check out our new website www.landanddesign.com

On Sep 29, 2015, at 10:34 AM, Greg Blodgett <greg1@ci.garden-grove.ca.us> wrote:

Can we call you re site c dof at 11.30

We have a conf call with dof at 1.30 and would like to have you on the call

Sent from my iPhone

Re:

Subject: Re:

From: Greg Blodgett <greg1@ci.garden-grove.ca.us>

Date: Tue, 29 Sep 2015 10:44:25 -0700 (PDT)

To: Matthew Reid <matt.reid@landanddesign.com>

ok

----- Original Message -----

From: "Matthew Reid" <matt.reid@landanddesign.com>

To: "Greg Blodgett" <greg1@ci.garden-grove.ca.us>

Sent: Tuesday, September 29, 2015 10:43:57 AM

Subject: Re:

I'm jammed with meetings today from 11am - 6pm tonight.

Matthew Reid
Land & Design, Inc.
3755 Avocado Blvd | #516 | LaMesa, CA 91942
858.735.1858 cell
Skype - [matthew.reid.ca](https://www.skype.com/people/matthew.reid.ca)
matt.reid@landanddesign.com

Check out our new website www.landanddesign.com

On Sep 29, 2015, at 10:34 AM, Greg Blodgett <greg1@ci.garden-grove.ca.us> wrote:

Can we call you re site c dof at 11.30

We have a conf call with dof at 1.30 and would like to have you on the call

Sent from my iPhone

Re:

Subject: Re:

From: Matthew Reid <matt.reid@landanddesign.com>

Date: Tue, 29 Sep 2015 10:48:26 -0700

To: Greg Blodgett <greg1@ci.garden-grove.ca.us>

could do tomorrow?

Matthew Reid

Land & Design, Inc.

3755 Avocado Blvd | #516 | LaMesa, CA 91942

858.735.1858 cell

Skype - [matthew.reid.ca](https://www.skype.com/user/matthew.reid.ca)

matt.reid@landanddesign.com

Check out our new website www.landanddesign.com

On Sep 29, 2015, at 10:44 AM, Greg Blodgett <greg1@ci.garden-grove.ca.us> wrote:

ok

----- Original Message -----

From: "Matthew Reid" <matt.reid@landanddesign.com>

To: "Greg Blodgett" <greg1@ci.garden-grove.ca.us>

Sent: Tuesday, September 29, 2015 10:43:57 AM

Subject: Re:

I'm jammed with meetings today from 11am - 6pm tonight.

Matthew Reid

Land & Design, Inc.

3755 Avocado Blvd | #516 | LaMesa, CA 91942

858.735.1858 cell

Skype - [matthew.reid.ca](https://www.skype.com/user/matthew.reid.ca)

matt.reid@landanddesign.com

Re:

Check out our new website www.landanddesign.com

On Sep 29, 2015, at 10:34 AM, Greg Blodgett <greg1@ci.garden-grove.ca.us> wrote:

Can we call you re site c dof at 11.30

We have a conf call with dof at 1.30 and would like to have you on the call

Sent from my iPhone

Subject: Site "C" Signs

From: Maria Parra <mariap@ci.garden-grove.ca.us>

Date: Tue, 29 Sep 2015 11:29:33 -0700 (PDT)

To: Matthew Reid <matt.reid@landanddesign.com>

CC: Lee Marino <leem@ci.garden-grove.ca.us>, Jane Chang <jane.chang@aecom.com>, Karl Hill <karlh@ci.garden-grove.ca.us>, Greg Blodgett <greg1@ci.garden-grove.ca.us>, David Rose <drose3@hotmail.com>

Hi Matt,

In discussing the proposed signage for Site "C", we are going to require that a light and glare study to be prepared as part of the CEQA addendum for the reader boards. Since is a unique sign request for the City, we want to make sure that all the information about any light and glare impacts, as well as any other impacts, are disclosed at the public hearing. Also, we suggest that before you prepare any study, that you forward a copy of the proposed sign plan for us to review.

The items to discuss in the study/ CEQA addendum should include, but not limited to:

- light and glare output
- angle of light dispersion
- motion/ movement
- image change time
- dimming during certain night hours/ times/ day time frame
- documentation on safety for non-freeway reader boards
- impacts to local street traffic

Best regards,

Maria Parra

Urban Planner

City of Garden Grove | Planning Services Division

11222 Acacia Parkway, Garden Grove, CA 92840

(714) 741-5312 | (714) 741-5578 fax

mariap@ci.garden-grove.ca.us | www.ci.garden-grove.ca.us

Community Development Department of the City of Garden Grove

"Providing Quality Services Through Creativity and Collaboration"

City Hall Hours:

Monday-Thursday: 7:30 a.m. to 5:30 p.m.

First Friday of the Month: 7:30 a.m. to 5:00 p.m.

Direct Website Links:

[Planning Division](#)

[Municipal Code, Title 9, Land Use](#)

[Zoning Map](#)

Subject: Fwd: City of GG - Removal of existing SCE OH utilities
From: David Rose <drose3@charter.net>
Date: Tue, 29 Sep 2015 16:26:15 -0700
To: Scott Stiles <sstiles@ci.garden-grove.ca.us>
CC: David Rose <drose3@hotmail.com>, Greg Blodgett <greg1@ci.garden-grove.ca.us>, Matt Reid <matt.reid@landanddesign.com>

Scott:

I hope this email finds you doing well, especially after getting your family out here.

Below please find an email from Brendan Murphy, the Operations Manager/Vice President for Turner Construction, whom we're interviewing as a potential GC for our Project, and who also is currently serving as the GC for the Great Wolf Lodge (GWL), indicating a significant and timely problem that they experienced while working on the GWL.

We definitely would like to meet with you and the City Staff NOW to alleviate our having the potential problem that GWL previously experienced.

Please advise as to how we can work together on this potential issue.

Thanks much.

Dave

Sent from my iPhone

Please forgive any errors. 😊

Begin forwarded message:

From: "Murphy, Brendan W - (SoCal)" <bwmurphy@tcco.com>
Date: September 29, 2015 at 3:39:41 PM PDT
To: "David Rose (drose3@charter.net)" <drose3@charter.net>
Cc: "Goede, Will - (SoCal)" <wgoede@tcco.com>, "WRSmith@bainbridge.com" <WRSmith@bainbridge.com>
Subject: City of GG - Removal of existing SCE OH utilities

David

During the preconstruction phase of Great Wolf Lodge we met weekly with The City of GG to coordinate the removal of the existing overhead SCE utilities located on site. It took approximately 4 months from the start of conversations with The City and SCE until the existing poles were physically removed from the site. The mass grading operation will start on your project once the existing poles are removed. This duration is important to consider for the upcoming resort project on Harbor Blvd. Please let me know if I can help.

Brendan W Murphy | Vice President Operations Manager
Turner Construction Company | 1900 South State College Boulevard, Suite 200 | Anaheim, CA 92806
direct 714.940.9000 | mobile 949.279.9377 | bwmurphy@tcco.com
[website](#) | [linkedin](#) | [facebook](#) | [twitter](#) | [youtube](#) | [pinterest](#)

Subject:

From: Greg Blodgett <greg1@ci.garden-grove.ca.us>

Date: Tue, 29 Sep 2015 17:09:33 -0700 (PDT)

To: ziad kahn <zkhan@langdonwilson.com>, David Rose <drose3@charter.net>

CC: Matthew Reid <matt.reid@landanddesign.com>

We will send Edison Electric the latest site plan so they can configure power to the site and look at a utility plan that removes the poles

can you send latest site plan to date

Greg Blodgett
SR Project Manager
City of Garden Grove
Economic Development

Subject: Fwd: City of GG & GWL-Negotiations with neighbors for site walls
From: David Rose <drose3@charter.net>
Date: Tue, 29 Sep 2015 18:27:29 -0700
To: Scott Stiles <sstiles@ci.garden-grove.ca.us>
CC: Greg Blodgett <greg1@ci.garden-grove.ca.us>, Matt Reid <matt.reid@landanddesign.com>, David Rose <drose3@hotmail.com>, carlosma@ci.garden-grove.ca.us

Scott:

In relation to the previous email I sent, here's another key concern/issue that Turner experienced by working on GWL (see email below) and hopefully City Staff and we (us?) can "head this off at the pass".

Please advise.

Thanks much.

Dave

Sent from my iPhone

Please forgive any errors. 😊

Begin forwarded message:

From: "Murphy, Brendan W - (SoCal)" <bwmurphy@tcco.com>
Date: September 29, 2015 at 4:45:44 PM PDT
To: "David Rose (drose3@charter.net)" <drose3@charter.net>
Cc: "WRSmith@bainbridge.com" <WRSmith@bainbridge.com>, "matt.reid@landanddesign.com" <matt.reid@landanddesign.com>, "Goede, Will - (SoCal)" <wgoede@tcco.com>
Subject: City of GG - Negotiations with neighbors for site walls

David

During the preconstruction phase of the Great Wolf project Turner met weekly with the developer and the City of GG to finalize the removal and replacement of the existing site walls adjacent to the residential properties. The negotiations took approximately 7 months to resolve. We know that your project includes new site walls adjacent to neighboring residential properties and that the installation of these new walls should ideally get installed in the first 2 months of the construction duration. Please feel free to reach out to me if I can be of any assistance.

Brendan W Murphy | Vice President Operations Manager
Turner Construction Company | 1900 South State College Boulevard, Suite 200 | Anaheim, CA 92806
direct 714.940.9000 | mobile 949.279.9377 | bwmurphy@tcco.com
[website](#) | [linkedin](#) | [facebook](#) | [twitter](#) | [youtube](#) | [pinterest](#)

Subject: Re: City of GG & GWL-Negotiations with neighbors for site walls

From: Scott Stiles <sstiles@ci.garden-grove.ca.us>

Date: Tue, 29 Sep 2015 18:47:50 -0700 (PDT)

To: David Rose <drose3@charter.net>

CC: Greg Blodgett <greg1@ci.garden-grove.ca.us>, Matt Reid <matt.reid@landanddesign.com>, David Rose <drose3@hotmail.com>, carlosma@ci.garden-grove.ca.us

David: absolutely. I will have Greg/Carlos arrange a mtg as soon as it's convenient for you. Early next week? I am in San Jose for the remainder of this week. Regards, Scott

Scott C. Stiles, ICMA-CM
City Manager / City of Garden Grove
11222 Acacia Parkway
Garden Grove, CA 92840
714-741-5100 (o) / 714-719-1810 (c)
www.ci.garden-grove.ca.us

Sent from my iPhone

On Sep 29, 2015, at 6:29 PM, David Rose <drose3@charter.net> wrote:

Scott:

In relation to the previous email I sent, here's another key concern/issue that Turner experienced by working on GWL (see email below) and hopefully City Staff and we (us?) can "head this off at the pass".

Please advise.

Thanks much.

Dave

Sent from my iPhone

Please forgive any errors. ☺

Begin forwarded message:

From: "Murphy, Brendan W - (SoCal)" <bwmurphy@tcco.com>

Date: September 29, 2015 at 4:45:44 PM PDT

To: "David Rose (drose3@charter.net)" <drose3@charter.net>

Cc: "WRSmith@bainbridge.com" <WRSmith@bainbridge.com>, "matt.reid@landanddesign.com" <matt.reid@landanddesign.com>, "Goede, Will - (SoCal)" <wgoede@tcco.com>

Subject: City of GG - Negotiations with neighbors for site walls

David

During the preconstruction phase of the Great Wolf project Turner met weekly with the developer and the

City of GG to finalize the removal and replacement of the existing site walls adjacent to the residential properties. The negotiations took approximately 7 months to resolve. We know that your project includes new site walls adjacent to neighboring residential properties and that the installation of these new walls should ideally get installed in the first 2 months of the construction duration. Please feel free to reach out to me if I can be of any assistance.

Brendan W Murphy | Vice President Operations Manager
Turner Construction Company | 1900 South State College Boulevard, Suite 200 | Anaheim, CA 92806
direct 714.940.9000 | mobile 949.279.9377 | bwmurphy@tcco.com
[website](#) | [linkedin](#) | [facebook](#) | [twitter](#) | [youtube](#) | [pinterest](#)

Subject: Re: City of GG & GWL-Negotiations with neighbors for site walls
From: David Rose <drose3@charter.net>
Date: Tue, 29 Sep 2015 19:06:48 -0700
To: Scott Stiles <sstiles@ci.garden-grove.ca.us>
CC: Greg Blodgett <greg1@ci.garden-grove.ca.us>, Matt Reid <matt.reid@landanddesign.com>, David Rose <drose3@hotmail.com>, carlosma@ci.garden-grove.ca.us

Have a safe trip.

Looking forward to working through these issues with City Staff.

Please advise.

Thanks.

Dave

Sent from my iPad

Please forgive any errors.

On Sep 29, 2015, at 6:47 PM, Scott Stiles <sstiles@ci.garden-grove.ca.us> wrote:

David: absolutely. I will have Greg/Carlos arrange a mtg as soon as it's convenient for you. Early next week? I am in San Jose for the remainder of this week. Regards, Scott

Scott C. Stiles, ICMA-CM
City Manager / City of Garden Grove
11222 Acacia Parkway
Garden Grove, CA 92840
714-741-5100 (o) / 714-719-1810 (c)
www.ci.garden-grove.ca.us

Sent from my iPhone

On Sep 29, 2015, at 6:29 PM, David Rose <drose3@charter.net> wrote:

Scott:

In relation to the previous email I sent, here's another key concern/issue that Turner experienced by working on GWL (see email below) and hopefully City Staff and we (us?) can "head this off at the pass".

Please advise.

Thanks much.

Dave

Sent from my iPhone

Please forgive any errors. 😊

Begin forwarded message:

From: "Murphy, Brendan W - (SoCal)" <bwmurphy@tcco.com>
Date: September 29, 2015 at 4:45:44 PM PDT
To: "David Rose (drose3@charter.net)" <drose3@charter.net>
Cc: "WRSmith@bainbridge.com" <WRSmith@bainbridge.com>, "matt.reid@landanddesign.com" <matt.reid@landanddesign.com>, "Goede, Will - (SoCal)" <wgoede@tcco.com>
Subject: City of GG - Negotiations with neighbors for site walls

David

During the preconstruction phase of the Great Wolf project Turner met weekly with the developer and the City of GG to finalize the removal and replacement of the existing site walls adjacent to the residential properties. The negotiations took approximately 7 months to resolve. We know that your project includes new site walls adjacent to neighboring residential properties and that the installation of these new walls should ideally get installed in the first 2 months of the construction duration. Please feel free to reach out to me if I can be of any assistance.

Brendan W Murphy | Vice President Operations Manager
Turner Construction Company | 1900 South State College Boulevard, Suite 200 | Anaheim, CA 92806
direct 714.940.9000 | mobile 949.279.9377 | bwmurphy@tcco.com
[website](#) | [linkedin](#) | [facebook](#) | [twitter](#) | [youtube](#) | [pinterest](#)

Subject: Re: City of GG & GWL-Negotiations with neighbors for site walls
From: Carlos Marquez <carlosma@ci.garden-grove.ca.us>
Date: Tue, 29 Sep 2015 19:53:49 -0700 (PDT)
To: David Rose <drose3@charter.net>
CC: Greg Blodgett <greg1@ci.garden-grove.ca.us>, Matt Reid <matt.reid@landanddesign.com>, David Rose <drose3@hotmail.com>

Hi David,

I'm glad that you are commencing with the preconstruction work at this time. I was on the team that handled the majority of the site prep work before conveying the properties to McW. One lesson I took from that was the timing of the site plan for the project. Edison refused to relocate/remove their facilities until Edison reviewed the utility portion of the site plan.

Even though you mentioned that you do not have space for easement purposes, SCE will not remove poles until they see a site plan that demonstrates such. SCE is most concerned with providing power to the residents on Choisser. The sooner I can present to SCE that there is no room for an easement to power the houses, the sooner I can commence on finding an alternative. If you have plans that are 90-95% complete then that will work as a good starting point.

Our goal is to see you guys succeed in accomplishing this project since L&D and the City will mutually benefit from the development . Let me know if you have questions or concerns.

Carlos

PS Greg and I will be happy to work with your development staff as things get closer to closing.

I
Sent from my iPhone

On Sep 29, 2015, at 7:09 PM, David Rose <drose3@charter.net> wrote:

Have a safe trip.

Looking forward to working through these issues with City Staff.

Please advise.

Thanks.

Dave

Sent from my iPad

Please forgive any errors.

On Sep 29, 2015, at 6:47 PM, Scott Stiles <sstiles@ci.garden-grove.ca.us> wrote:

David: absolutely. I will have Greg/Carlos arrange a mtg as soon as it's convenient for you. Early next week? I am in San Jose for the remainder of this week. Regards, Scott

Scott C. Stiles, ICMA-CM
City Manager / City of Garden Grove
11222 Acacia Parkway
Garden Grove, CA 92840
714-741-5100 (o) / 714-719-1810 (c)
www.ci.garden-grove.ca.us

Sent from my iPhone

On Sep 29, 2015, at 6:29 PM, David Rose <drose3@charter.net> wrote:

Scott:

In relation to the previous email I sent, here's another key concern/issue that Turner experienced by working on GWL (see email below) and hopefully City Staff and we (us?) can "head this off at the pass".

Please advise.

Thanks much.

Dave

Sent from my iPhone

Please forgive any errors. 😊

Begin forwarded message:

From: "Murphy, Brendan W - (SoCal)" <bwmurphy@tcco.com>
Date: September 29, 2015 at 4:45:44 PM PDT
To: "David Rose (drose3@charter.net)" <drose3@charter.net>
Cc: "WRSmith@bainbridge.com" <WRSmith@bainbridge.com>, "matt.reid@landanddesign.com" <matt.reid@landanddesign.com>, "Goede, Will - (SoCal)" <wgoede@tcco.com>
Subject: City of GG - Negotiations with neighbors for site walls

David

During the preconstruction phase of the Great Wolf project Turner met weekly with the developer and the City of GG to finalize the removal and replacement of the existing site walls adjacent to the residential properties. The negotiations took approximately 7 months to resolve. We know that your project includes new site walls adjacent to neighboring residential properties and that the installation of these new walls should ideally get installed in the first 2 months of the construction duration. Please feel free to reach out to me if I can be of any assistance.

Brendan W Murphy | Vice President Operations Manager
Turner Construction Company | 1900 South State College Boulevard, Suite 200 | Anaheim, CA 92806

Re: City of GG & GWL-Negotiations with neighbors for site walls

|||| | [direct 714.940.9000](tel:714.940.9000) | [mobile 949.279.9377](tel:949.279.9377) | bwmurphy@tcco.com
[website](#) | [linkedin](#) | [facebook](#) | [twitter](#) | [youtube](#) | [pinterest](#)

Subject: Re: City of GG & GWL-Negotiations with neighbors for site walls

From: David Rose <drose3@charter.net>

Date: Tue, 29 Sep 2015 22:33:51 -0700

To: Carlos Marquez <carlosma@ci.garden-grove.ca.us>

CC: Greg Blodgett <greg1@ci.garden-grove.ca.us>, Matt Reid <matt.reid@landanddesign.com>, David Rose <drose3@hotmail.com>

To clarify, we're at 90-95% of schematics, not CD's.

Sent from my iPhone

Please forgive any errors. 😊

On Sep 29, 2015, at 7:53 PM, Carlos Marquez <carlosma@ci.garden-grove.ca.us> wrote:

Hi David,

I'm glad that you are commencing with the preconstruction work at this time. I was on the team that handled the majority of the site prep work before conveying the properties to McW. One lesson I took from that was the timing of the site plan for the project. Edison refused to relocate/remove their facilities until Edison reviewed the utility portion of the site plan.

Even though you mentioned that you do not have space for easement purposes, SCE will not remove poles until they see a site plan that demonstrates such. SCE is most concerned with providing power to the residents on Choisser. The sooner I can present to SCE that there is no room for an easement to power the houses, the sooner I can commence on finding an alternative. If you have plans that are 90-95% complete then that will work as a good starting point.

Our goal is to see you guys succeed in accomplishing this project since L&D and the City will mutually benefit from the development. Let me know if you have questions or concerns.

Carlos

PS Greg and I will be happy to work with your development staff as things get closer to closing.

I

Sent from my iPhone

On Sep 29, 2015, at 7:09 PM, David Rose <drose3@charter.net> wrote:

Have a safe trip.

Looking forward to working through these issues with City Staff.

Please advise.

Thanks.

Dave

Sent from my iPad

Please forgive any errors.

On Sep 29, 2015, at 6:47 PM, Scott Stiles <ssstiles@ci.garden-grove.ca.us> wrote:

David: absolutely. I will have Greg/Carlos arrange a mtg as soon as it's convenient for you. Early next week? I am in San Jose for the remainder of this week. Regards, Scott

Scott C. Stiles, ICMA-CM
City Manager / City of Garden Grove
11222 Acacia Parkway
Garden Grove, CA 92840
714-741-5100 (o) / 714-719-1810 (c)
www.ci.garden-grove.ca.us

Sent from my iPhone

On Sep 29, 2015, at 6:29 PM, David Rose <drose3@charter.net> wrote:

Scott:

In relation to the previous email I sent, here's another key concern/issue that Turner experienced by working on GWL (see email below) and hopefully City Staff and we (us?) can "head this off at the pass".

Please advise.

Thanks much.

Dave

Sent from my iPhone

Please forgive any errors. 😊

Begin forwarded message:

From: "Murphy, Brendan W - (SoCal)" <bwmurphy@tcco.com>
Date: September 29, 2015 at 4:45:44 PM PDT
To: "David Rose (drose3@charter.net)" <drose3@charter.net>
Cc: "WRSmith@bainbridge.com" <WRSmith@bainbridge.com>, "matt.reid@landanddesign.com" <matt.reid@landanddesign.com>, "Goede, Will - (SoCal)" <wgoede@tcco.com>
Subject: City of GG - Negotiations with neighbors for site walls

David

During the preconstruction phase of the Great Wolf project Turner met weekly with the developer and the City of GG to finalize the removal and replacement of the existing site walls adjacent to the residential properties. The negotiations took approximately 7 months to resolve. We know that your project includes new site walls adjacent to neighboring residential properties and that the installation of these new walls should ideally get installed in the first 2 months of the construction duration. Please feel free to reach out to me if I can be of any assistance.

Brendan W Murphy | Vice President Operations Manager
Turner Construction Company | 1900 South State College Boulevard, Suite 200 | Anaheim, CA 92806
direct 714.940.9000 | mobile 949.279.9377 | bwmurphy@tcco.com
[website](#) | [linkedin](#) | [facebook](#) | [twitter](#) | [youtube](#) | [pinterest](#)

Subject: Fwd: Site C - Add service request for RK Engineering tasks
From: Maria Parra <mariap@ci.garden-grove.ca.us>
Date: Wed, 30 Sep 2015 08:48:44 -0700 (PDT)
To: Alana Cheng <alanac@ci.garden-grove.ca.us>
CC: Jane Chang <jane.chang@aecom.com>, Matthew Reid <matt.reid@landanddesign.com>

Hi Alana,

Attached is the scope of work for the added services to the AECOM contract for the Site "C" addendum. Please coordinate with Jane Chang at AECOM and Matt Reid to amend the agreements and to secure the deposit.

Thanks!

Maria Parra

Urban Planner
City of Garden Grove | Planning Services Division
11222 Acacia Parkway, Garden Grove, CA 92840
(714) 741-5312 | (714) 741-5578 fax
mariap@ci.garden-grove.ca.us | www.ci.garden-grove.ca.us

Community Development Department of the City of Garden Grove
"Providing Quality Services Through Creativity and Collaboration"

City Hall Hours:
Monday-Thursday: 7:30 a.m. to 5:30 p.m.
First Friday of the Month: 7:30 a.m. to 5:00 p.m.

Direct Website Links:
[Planning Division](#)
[Municipal Code, Title 9, Land Use](#)
[Zoning Map](#)

GG_Site C_Add Service_Sep2015.pdf	Content-Type: application/pdf Content-Encoding: base64
--	---



AECOM 714.567.2400 tel
999 Town & Country Road 714.567.2409 fax
Orange, CA 92868
www.aecom.com

wed 30 Sep 2015
08:48:44 - 0700

September 28, 2015

Mr. Karl Hill
Acting Community Development Director
Community Development Department
City of Garden Grove
11222 Acacia Parkway
Garden Grove, CA 92840

Subject: Add Service Request for International West Hotel – Harbor East (Site C) Addendum to Final Initial Study/Mitigated Negative Declaration

Dear Karl,

Per our September 22, 2015 meeting, this correspondence serves as a request for an additional services amendment to our current Professional Services Agreement, executed between the City of Garden Grove and AECOM, dated August 24, 2015 and based on our Scope of Work dated June 30, 2015. Please see the detailed explanation of tasks that will be performed that are outside of the Scope of Work dated June 30, 2015.

Scope of Work

Task 1 – Preparation of Updated Trip Generation and ULI Shared Parking Analysis

RK Engineering Group, Inc. (RK) prepared a traffic impact study and ULI Shared Parking analysis for the proposed project in July 2012. Based on the current proposed project, RK will prepare an updated traffic impact study and ULI Shared Parking analysis. RK will compare the trip generation of the previously approved development plan to the new and updated development plan utilizing the ITE Trip Generation Manual. If the new project is generating fewer trips than the approved project, it may not be necessary to prepare a traffic study analyzing all 21 previously identified intersections. This task includes:

1. Review of the site plan for the project from a traffic circulation and access standpoint.
2. Discuss the project with AECOM project team in a kick-off meeting.
3. Obtain the updated development plan and calculate the trip generation for the proposed project and compare it to the previously approved development plan.
4. Determine parking requirements for all of the existing uses based on the City of Garden Grove Parking Code.
5. Update the ULI shared parking analysis based on the City of Garden Grove parking rates and/or City staff approved rates.
6. Develop project recommendations with respect to peak parking demand.
7. Provide a letter with tables and exhibits that outline the results of the trip generation comparison.

8. Share the findings with AECOM and the City of Garden to determine if more analysis is needed.

Task 2 – Preparation of Updated Acoustical Study

RK prepared an acoustical study for the proposed project in July 2012. Based on the current proposed project, RK will prepare an updated acoustical report. The primary source of noise impacting the project site would be local traffic noise from the local roadway system. The primary sources of noise impacting the adjacent properties would be short-term construction noise and long-term operational noise (i.e., condenser units, truck deliveries, loading/unloading and parking structure noise). RK will utilize data from the previously approved acoustical study for the revised analysis. RK will need electronic file of site plans (including grading information) and elevation of surrounding residential community. This task includes:

1. Review of the preliminary site plan for the project from an acoustical standpoint.
2. Discuss the project with AECOM project team in a kick-off meeting.
3. Utilize the FHWA Construction Noise Model to determine the short-term construction noise impacts for the project. Determine the exterior noise impact to the surrounding adjacent properties and evaluate effectiveness of previously identified mitigation measures to alleviate any potentially significant noise impact, and identify additional measures, if necessary.
4. Utilize a version of the stationary noise analysis software to determine the operational noise impacts from the project site to the surrounding adjacent properties. Establish the exterior noise impact the project site would (if any) have to the adjacent properties, and evaluate effectiveness of previously identified mitigation measures to alleviate any potentially significant noise impact, and identify additional measures, if necessary.
5. Utilize a version of the FHWA Noise Prediction Model to determine the change in the noise level on the local roadway system as a result of the project.
6. Establish outdoor noise impacts and required mitigation measures, if applicable.
7. Summarize the results of the analysis in a preliminary acoustical study that will address the exterior noise impacts to and from the project site for both short-term and long-term noise impacts and provide recommended mitigation measures, if necessary.

Task 3 – Preparation of Updated Air Quality Impact Study and Greenhouse Gas Analysis

RK prepared an air quality and greenhouse gas (GHG) study for the proposed project in July 2012. Based on the current proposed project, RK will prepare an updated and revised air quality impact study including a GHG analysis. RK will utilize data from the previously approved air quality and GHG analyses for the revised reports. RK will need electronic file of proposed site plan and preliminary grading plan including roadway elevations adjacent to the project. This task includes:

1. Review of the site plan and traffic study/trip generation for the project from an air quality standpoint.
2. Discuss the project with AECOM project team in a kick-off meeting.



3. Discuss construction activity impacts.
4. Update greenhouse gas impacts and emissions. Review project as it relates to AB32 and SB375.
5. Update the CALINE4 emissions analysis for up to four (4) intersections, if needed.
6. Identify mobile source emission calculations using the URBEMIS 2007 computer model.
7. Develop project recommendations.
8. Summarize the results of the analysis in an air quality impact study to address the short-term and long-term air quality impacts and evaluate effectiveness of previously identified mitigation measures to alleviate any potentially significant noise impact, and identify additional measures, if necessary.

Task 4 – Coordination with the Subconsultant and City Staff

AECOM staff will coordinate with the project subconsultant, RK (for air quality, noise, and traffic) and City staff to complete this effort. This task includes attending up to two (2) meetings or conference calls with RK and/or City staff.

Budget

For the professional services described in the above Scope of Work, AECOM proposes the following Professional Services Fee, to be completed on a Time and Material basis, not to exceed:

Task	DESCRIPTION	FEE (USD)
1	Preparation of Updated Trip Generation and ULI Shared Parking Analysis	\$5,800.00
2	Preparation of Updated Acoustical Study	\$3,950.00
3	Preparation of Updated Air Quality Impact Study and Greenhouse Gas Analysis	\$4,250.00
4	Coordination with the Subconsultant and City Staff	\$1,400.00
TOTAL PROFESSIONAL SERVICES FEE		\$15,400.00

Please do not hesitate to give me a call at (714) 567-2788 if you have any questions related to this request. We look forward to the continued working relationships with you and City of Garden Grove on this and future projects. Please provide your written authorization for AECOM to proceed our work as described above.

Yours sincerely,

Jane Chang
Project Manager



AGREED:

CITY OF GARDEN GROVE

By: _____

Title: _____

Date: _____

cc: Greg Blodgett, City of Garden Grove
Maria Parra, City of Garden Grove
Thomas Holm, AECOM

September 23, 2015

Ms. Jane Chang
AECOM
999 Town & Country Road,
Orange, CA 92868

Subject: Updated Trip Generation and ULI Shared Parking Analysis for Garden Grove Hotel Site C, City of Garden Grove

Dear Ms. Chang:

Introduction

RK ENGINEERING GROUP, INC. (RK) is pleased to submit this proposed Agreement to provide an updated traffic impact study for the proposed Garden Grove Hotel Site C project. The proposed project is located at the northeast corner of Harbor Boulevard and Twintree Avenue in the City of Garden Grove. RK completed a traffic impact study and ULI Shared Parking analysis for the development dated July 27, 2012. The project was later approved by the City.

Based on our conversation today, representatives of the project are proposing to revise the development plan for the mixed use hotel project. The number of keys is proposed to decrease while the conference/meeting space and restaurant square feet may increase. This change will result in an updated traffic and ULI Shared Parking analysis for the project.

RK will compare the trip generation of the previously approved development plan to the new and updated development plan utilizing the ITE Trip Generation Manual. If the new project is generating fewer trips than the approved project the City of Garden Grove may not require a complete traffic study that analyzed all twenty-one intersections. RK will also update the ULI Shared Parking analysis based on the new development plan.

Scope of Work

1. Review the Site Plan for the project from a traffic circulation and access standpoint.
2. Discuss the project with AECOM project team in a kick off meeting.
3. Obtain the updated development plan and calculate the trip generation for the proposed project and compare it to the previously approved development plan.
4. Determine parking requirements for all of the existing uses based on the City of Garden Grove Parking Code.

5. Update the ULI shared parking analysis based upon the City of Garden Grove parking rates and/or City Staff approved rates.
6. Develop project recommendations with respect to peak parking demand.
7. Provide a letter with tables and exhibits that outline the results of the trip generation comparison.
8. Share the findings with AECOM and the City of Garden Grove to determine if more analysis is needed.

Professional Fees

The fee for the work outlined in this proposal is based upon personnel charges plus direct expenses as indicated in the attached Exhibit A. **The fixed fee to accomplish the above Scope of Work is \$5,800.** This fee is based upon analysis of the Original Site Plan received by RK from the Client at the time RK initiates the work. Should the original Site Plan received by RK be modified (per the Client or their respective associates) after the work is initiated by RK, then RK will require a change Order and budget modification to accommodate changes before completing the work. Attendance at public hearings is based on Billing Rates attached in Exhibit A.

Three copies (two bound and one original for the client's use) of the project report would be prepared. Monthly billings for RK will be based upon the attached Exhibit A - BILLING RATES FOR RK ENGINEERING GROUP, INC. Invoices that are more than 90 days past due are subject to interest at the maximum permitted by law.

Limitation of Liability

The Client agrees to limit the Design Professional's liability to the Client and to all construction Contractors and Subcontractors on the project, due to the Design Professional's negligent acts, errors, or omissions, such that the total aggregate liability of the Design Professional to all those named shall not exceed \$50,000 or the Design Professional's total fee for services rendered on this project, whichever is greater.

Ownership of Documents

All reports, plans, specifications, field data, notes and other documents, including all documents on electronic media, prepared by RK, as instruments of service shall remain the property of RK. The Client may use these documents to secure approval of his/her projects; however, they may not be modified or changed in any way. The items in this proposal/contract are to be considered **CONFIDENTIAL** and may not be shared with any other entity without the written permission of RK Engineering Group, Inc.

Dispute Resolution

In an effort to resolve any conflicts that arise during the Project or following the completion of the Project, the Client and RK agree that all disputes between them arising out of or relating to this Agreement or the Project shall be submitted to nonbinding mediation unless the parties mutually agree otherwise.

In the event that a lawsuit is brought for the enforcement of any of the terms of this agreement, the prevailing party should be entitled to attorney fees and costs in addition to any damages. This agreement can be terminated by either party based upon a written request to terminate the work. The client will pay RK for all work that is completed prior to the termination of the work.

Time Schedule

It is estimated that the trip generation and shared parking study will take approximately 10 working days to complete from the date of authorization, and date of receipt of data essential for the study. Additionally, any delays resulting from circumstances beyond our control, such as weather, shall extend the time schedule.

Qualifications

RK is located in Newport Beach, California and specializes in transportation planning and traffic/acoustical engineering for governmental agencies and the business community. The firm principals and associates have over 70 years of combined engineering and planning experience throughout Southern California at the regional, local and individual project levels. The experience of the firm's personnel in transportation planning and traffic/acoustical engineering provides the special skills necessary for determining practical and meaningful traffic solutions.

Limitation of Liability

The Client agrees to limit the Design Professional's liability to the Client and to all construction Contractors and Subcontractors on the project, due to the Design Professional's negligent acts, errors, or omissions, such that the total aggregate liability of the Design Professional to all those named shall not exceed \$50,000 or the Design Professional's total fee for services rendered on this project, whichever is greater.

This letter can serve as a Memorandum of Agreement and our authorization to proceed. Please sign one copy and return it to us for our files. We are looking forward to serving you on this project. **This proposal is valid for sixty days, if signed by the client.**

Ms. Jane Chang
AECOM
September 23, 2015
Page 4

RK is looking forward to the possibility of teaming with Aecom on this project. If you have any questions regarding this proposal, please call me at (949) 474-0809.

Respectfully submitted,
RK ENGINEERING GROUP, INC.



Rogier Goedecke
Vice President, Operations

Attachment

CONTRACT APPROVAL:

Approved by:

Title:

Firm:

AECOM

Date:

Exhibit A

Billing Rates for RK ENGINEERING GROUP, INC.

Compensation for Services

The Consultants Billing rates for services are as follows:

<u>Position</u>	<u>Hourly Rate</u>
Principal	\$165.00
Associate Principal	\$150.00
Senior Associate	\$140.00
Associate	\$130.00
Principal Engineer/Principal Planner/Principal Designer	\$120.00
Senior Engineer/Senior Planner/Senior Designer	\$110.00
Engineer/Planner III	\$105.00
Engineer/Planner II	\$ 95.00
Engineer/Planner I	\$ 90.00
Assistant Engineer/Planner	\$ 80.00
Transportation Analyst	\$ 65.00
Senior Engineering Technician	\$ 75.00
Engineering Technician III	\$ 70.00
Engineering Technician II	\$ 60.00
Engineering Technician I	\$ 50.00
Engineering Aide	\$ 45.00
Executive Assistant	\$ 65.00
Administrative Assistant	\$ 50.00
Administrative Aide	\$ 40.00
Clerical Aide	\$ 35.00

General

- (1) Reimbursable direct costs, such as reproduction, supplies, messenger service, long-distance telephone calls, travel and traffic counts will be billed at cost plus ten (10) percent.
- (2) Hourly rates apply to work time, travel time and time spent at public hearings and meetings. For overtime work and expert witness work, the above rates may be increased 50 percent. Hourly rates for depositions and trials will be increased by 100%
- (3) Client payment for professional services is not contingent upon the client receiving payment from other parties.
- (4) Billing statements for work will be submitted monthly. Statements are payable within thirty (30) days of the receipt by client of statement. Any statement unpaid after thirty (30) days shall be subject to interest at the maximum permitted by law.

September 23, 2015

Ms. Jane Chang
AECOM
999 Town & Country Road,
Orange, CA 92868

Subject: Updated Garden Grove Hotel Site C Acoustical Study, City of Garden Grove

Dear Ms. Chang:

Introduction

RK ENGINEERING GROUP, INC. (RK) is pleased to submit this proposed Agreement to provide an updated acoustical report for the proposed Garden Grove Hotel Site C project. The proposed project is located at the northeast corner of Harbor Boulevard and Twintree Avenue in the City of Garden Grove. RK completed an Acoustical Study for the development dated July 27, 2012. The project was later approved by the City.

Based on our conversation today, representatives of the project are proposing to revise the development plan for the mixed use hotel project. The number of keys is proposed to decrease while the conference/meeting space and restaurant square feet may increase. Also the development is proposing to consist of two buildings and not three as originally analyzed. This change will result in the need for an updated acoustical analysis.

The primary source of noise impacting the project site would be local traffic noise from the local roadway system. The primary sources of noise impacting the adjacent properties would be short-term construction noise and long-term operational noise (i.e. condenser units, truck deliveries, loading/unloading and parking structure noise).

RK will utilize data from the previously approved acoustical study for the revised analysis.

In order to facilitate your project in the most efficient and timely manner, RK would request the following project information:

- Electronic file (emailed to: rg@rkengineer.com) of site plans (including grading information) and elevation of surrounding residential community.

Scope of Work

The following Scope of Work is proposed by RK for this study effort:

1. Review the preliminary site plan for the project from an acoustical standpoint.
2. Discuss the project with AECOM Team in a kick-off meeting.
3. Utilize the FHWA Construction noise model to determine the short-term construction noise impacts for the project. Determine the exterior noise impact to the surrounding adjacent properties and provide mitigation measures to alleviate any potential significant noise impact.
4. Utilize a version of the stationary noise analysis software to determine the operational noise impacts from the project site to the surrounding adjacent properties. Establish the exterior noise impact the project site would (if any) have to the adjacent properties, and provide mitigation measures to mitigate any potential noise impact.
5. Utilize a version on the FHWA Noise Prediction Model to determine the change in the noise level on the local roadway system as a result of the project.
6. Establish outdoor noise impacts and required mitigation measures, if applicable.
7. Summarize the results of the analysis in a preliminary acoustical study that will address the exterior noise impacts to and from the project site for both short-term and long-term noise impacts and provide recommended mitigation measures, if necessary.

Professional Fees

The fee for the work outlined in this proposal is based upon personnel charges plus direct expenses as indicated in the attached Exhibit A. **The fixed fee to accomplish the above Scope of Work is \$3,950.** This fee is based upon analysis of the Original Site Plan received by RK from the Client at the time RK initiates the work. Should the original Site Plan received by RK be modified (per the Client or their respective associates) after the work is initiated by RK, then RK will require a change Order and budget modification to accommodate changes before completing the work.

An Electronic PDF copy of the project report will be emailed to the client. If requested, three copies (two bound and one original for the client's use) of the project report would

be prepared. Monthly billings for RK will be based upon the attached Exhibit A - BILLING RATES FOR RK ENGINEERING GROUP, INC. **Payments are due within 30 days of invoice date.** Invoices that are more than 90 days past due are subject to interest at the maximum permitted by law.

The proposed fee does not include attendance at public hearings/meetings, which may be required to secure approval of the project. If these are required and requested, RK would be pleased to attend these meetings and billing would be based upon the billing rates included in Exhibit A. Any meetings after 5:00 PM will be billed at 1.5 times our normal rates.

Limitation of Liability

The Client agrees to limit the Design Professional's liability to the Client and to all construction Contractors and Subcontractors on the project, due to the Design Professional's negligent acts, errors, or omissions, such that the total aggregate liability of the Design Professional to all those named shall not exceed \$50,000 or the Design Professional's total fee for services rendered on this project, whichever is greater.

Ownership of Documents

All reports, plans, specifications, field data, notes and other documents, including all documents on electronic media, prepared by RK as instruments of service shall remain the property of RK. The Client may use these documents to secure approval of his/her projects, however, they may not be modified or changed in any way.

Dispute Resolution

In an effort to resolve any conflicts that arise during the Project or following the completion of the Project, the Client and RK agree that all disputes between them arising out of or relating to this Agreement or the Project shall be submitted to nonbinding mediation unless the parties mutually agree otherwise.

In the event that a lawsuit is brought for the enforcement of any of the terms of this agreement, the prevailing party should be entitled to attorney fees and costs in addition to any damages. This agreement can be terminated by either party based upon a written request to terminate the work. The client will pay RK for all work that is completed prior to the termination of the work.

Time Schedule

It is estimated that the Acoustical Study will take approximately 10 working days to complete from the date of authorization, and date of receipt of data essential for the study. Additionally, any delays resulting from circumstances beyond our control, such as weather, shall extend the time schedule.

Qualifications

RK is located in Newport Beach, California and specializes in transportation planning and traffic/acoustical engineering for governmental agencies and the business community. The firm principals and associates have over 70 years of combined engineering and planning experience throughout Southern California at the regional, local and individual project levels. The experience of the firm's personnel in transportation planning and traffic/acoustical engineering provides the special skills necessary for determining practical and meaningful traffic solutions.

This letter can serve as a Memorandum of Agreement and our authorization to proceed. **Please sign one copy and return it to us for our files even if you issue your own contract.** We are looking forward to serving you on this project. **This proposal is valid for sixty days, if signed by the client.**

If you have any questions regarding this proposal, please call me at (949) 474-0809.

Respectfully submitted,
RK ENGINEERING GROUP, INC.

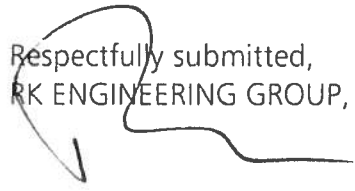

Rogier Goedecke
Vice President, Operations

Attachment

CONTRACT APPROVAL:

Approved by: _____
Title: _____
Firm: _____ AECOM _____
Date: _____

Exhibit A

Billing Rates for RK ENGINEERING GROUP, INC.

Compensation for Services

The Consultants Billing rates for services are as follows:

<u>Position</u>	<u>Hourly Rate</u>
Principal	\$165.00
Associate Principal	\$150.00
Senior Associate	\$140.00
Associate	\$130.00
Principal Engineer/Principal Planner/Principal Designer	\$120.00
Senior Engineer/Senior Planner/Senior Designer	\$110.00
Engineer/Planner III	\$105.00
Engineer/Planner II	\$ 95.00
Engineer/Planner I	\$ 90.00
Assistant Engineer/Planner	\$ 80.00
Transportation Analyst	\$ 65.00
Senior Engineering Technician	\$ 75.00
Engineering Technician III	\$ 70.00
Engineering Technician II	\$ 60.00
Engineering Technician I	\$ 50.00
Engineering Aide	\$ 45.00
Executive Assistant	\$ 65.00
Administrative Assistant	\$ 50.00
Administrative Aide	\$ 40.00
Clerical Aide	\$ 35.00

General

- (1) Reimbursable direct costs, such as reproduction, supplies, messenger service, long-distance telephone calls, travel and traffic counts will be billed at cost plus ten (10) percent.
- (2) Hourly rates apply to work time, travel time and time spent at public hearings and meetings. For overtime work and expert witness work, the above rates may be increased 50 percent. Hourly rates for depositions and trials will be increased by 100%
- (3) Client payment for professional services is not contingent upon the client receiving payment from other parties.
- (4) Billing statements for work will be submitted monthly. Statements are payable within thirty (30) days of the receipt by client of statement. Any statement unpaid after thirty (30) days shall be subject to interest at the maximum permitted by law.

September 23, 2015

Ms. Jane Chang
AECOM
999 Town & Country Road,
Orange, CA 92868

**Subject: Updated Garden Grove Hotel Site C Air Quality Impact Study,
City of Garden Grove**

Dear Ms. Chang:

Introduction

RK ENGINEERING GROUP, INC. (RK) is pleased to submit this proposed Agreement to provide an updated and revised air quality impact study including a Green House Gas Analysis (GHG) for the Garden Grove Hotel Site C Project. The proposed project is located at the northeast corner of Harbor Boulevard and Twintree Avenue in the City of Garden Grove. RK completed an Air Quality and Green House Gas Study for the development dated July 27, 2012. The project was later approved by the City.

Based on our conversation today, representatives of the project are proposing to revise the development plan for the mixed use hotel project. The number of keys is proposed to decrease while the conference/meeting space and restaurant square feet may increase. Also the development is proposing to consist of two buildings and not three as originally analyzed. This change will result in the need for an updated Air Quality and Green House Gas analysis.

RK will utilize data from the previously approved Air Quality and Green House Gas analyses for the revised reports.

In order to facilitate your project in the most efficient and timely manner, RK would request the following project information:

- Electronic File of proposed site plan and preliminary grading plan including roadway elevations adjacent to the project (email to rg@rkengineer.com).

Scope of Work

The following Scope of Work is proposed by RK for this study effort:

1. Review the site plan and traffic study/trip generation for the project from an air quality standpoint.
2. Discuss the project with AECOM Team in a kick off meeting.
3. Discuss construction activity impacts.
4. Update greenhouse gas impacts and emissions. Review project as it relates to AB32 and SB375.
5. Update the CALINE4 emissions analysis for up to four (4) intersections, if needed.
6. Identify mobile source emission calculations using the URBEMIS 2007 computer model.
7. Develop project recommendations.
8. Summarize the results of the analysis in an air quality impact study to address the short-term and long-term air quality impacts, and recommended mitigation measures if necessary.

Professional Fees

The fee for the work outlined in this proposal is based upon personnel charges plus direct expenses as indicated in the attached Exhibit A. **The fixed fee Scope of Work will be \$4,250.** This fee is based upon analysis of the Original Site Plan received by RK from the Client at the time RK initiates the work. Should the original Site Plan received by RK be modified (per the Client or their respective associates) after the work is initiated by RK, then RK will require a change Order and budget modification to accommodate changes before completing the work.

Three copies (two bound and one original for the client's use) of the project report would be prepared. Monthly billings for RK will be based upon the attached Exhibit A - BILLING RATES FOR RK ENGINEERING GROUP, INC. Payments are due within 30 days of the invoice date. Invoices that are more than 90 days past due are subject to interest at the maximum permitted by law.

The proposed fee does not include attendance at public hearings/meetings, which may be required to secure approval of the project. If these are required and requested, RK would be pleased to attend these meetings and billing would be based upon the billing rates included in Exhibit A. Any meetings after 5:00 PM will be billed at 1.5 times our normal rates.

Limitation of Liability

The Client agrees to limit the Design Professional's liability to the Client and to all construction Contractors and Subcontractors on the project, due to the Design Professional's negligent acts, errors, or omissions, such that the total aggregate liability of the Design Professional to all those named shall not exceed \$50,000 or the Design Professional's total fee for services rendered on this project, whichever is greater.

Ownership of Documents

All reports, plans, specifications, field data, notes and other documents, including all documents on electronic media, prepared by RK as instruments of service shall remain the property of RK. The Client may use these documents to secure approval of his/her projects, however, they may not be modified or changed in any way.

Dispute Resolution

In an effort to resolve any conflicts that arise during the Project or following the completion of the Project, the Client and RK agree that all disputes between them arising out of or relating to this Agreement or the Project shall be submitted to nonbinding mediation unless the parties mutually agree otherwise.

In the event that a lawsuit is brought for the enforcement of any of the terms of this agreement, the prevailing party should be entitled to attorney fees and costs in addition to any damages. This agreement can be terminated by either party based upon a written request to terminate the work. The client will pay RK for all work that is completed prior to the termination of the work.

Time Schedule

It is estimated that the Garden Grove Hotel Site C Project Air Quality Impact Study will take approximately 15 working days to complete from the date of authorization, and date of receipt of data essential for the study. Additionally, any delays resulting from circumstances beyond our control, such as weather, shall extend the time schedule.

Qualifications

RK is located in Newport Beach, California and specializes in transportation planning and traffic/acoustical engineering for governmental agencies and the business community. The firm principals and associates have over 70 years of combined engineering and planning experience throughout Southern California at the regional, local and individual project levels. The experience of the firm's personnel in transportation planning and traffic/acoustical engineering provides the special skills necessary for determining practical and meaningful traffic solutions.

This letter can serve as a Memorandum of Agreement and our authorization to proceed. **Please sign one copy and return it to us for our files even if you issue your own contract.** We are looking forward to serving you on this project. **This proposal is valid for sixty days, if signed by the client.**

If you have any questions regarding this proposal, please call me at (949) 474-0809.



Respectfully submitted,
RK ENGINEERING GROUP, INC.

Rogier Goedecke
Vice President, Operations

Attachment

CONTRACT APPROVAL:

Approved by: _____
Title: _____
Firm: AECOM
Date: _____

Exhibit A

Billing Rates for RK ENGINEERING GROUP, INC.

Compensation for Services

The Consultants Billing rates for services are as follows:

<u>Position</u>	<u>Hourly Rate</u>
Principal	\$165.00
Associate Principal	\$150.00
Senior Associate	\$140.00
Associate	\$130.00
Principal Engineer/Principal Planner/Principal Designer	\$120.00
Senior Engineer/Senior Planner/Senior Designer	\$110.00
Engineer/Planner III	\$105.00
Engineer/Planner II	\$ 95.00
Engineer/Planner I	\$ 90.00
Assistant Engineer/Planner	\$ 80.00
Transportation Analyst	\$ 65.00
Senior Engineering Technician	\$ 75.00
Engineering Technician III	\$ 70.00
Engineering Technician II	\$ 60.00
Engineering Technician I	\$ 50.00
Engineering Aide	\$ 45.00
Executive Assistant	\$ 65.00
Administrative Assistant	\$ 50.00
Administrative Aide	\$ 40.00
Clerical Aide	\$ 35.00

General

- (1) Reimbursable direct costs, such as reproduction, supplies, messenger service, long-distance telephone calls, travel and traffic counts will be billed at cost plus ten (10) percent.
- (2) Hourly rates apply to work time, travel time and time spent at public hearings and meetings. For overtime work and expert witness work, the above rates may be increased 50 percent. Hourly rates for depositions and trials will be increased by 100%
- (3) Client payment for professional services is not contingent upon the client receiving payment from other parties.
- (4) Billing statements for work will be submitted monthly. Statements are payable within thirty (30) days of the receipt by client of statement. Any statement unpaid after thirty (30) days shall be subject to interest at the maximum permitted by law.

Subject: Re: Site C - Add service request for RK Engineering tasks
From: Alana Cheng <alanac@ci.garden-grove.ca.us>
Date: Wed, 30 Sep 2015 09:14:58 -0700 (PDT)
To: Maria Parra <mariap@ci.garden-grove.ca.us>
CC: Jane Chang <jane.chang@aecom.com>, Matthew Reid <matt.reid@landanddesign.com>

Okay, thank you Maria. I will coordinate with them

thanks!
Alana

From: "Maria Parra" <mariap@ci.garden-grove.ca.us>
To: "Alana Cheng" <alanac@ci.garden-grove.ca.us>
Cc: "Jane Chang" <jane.chang@aecom.com>, "Matthew Reid" <matt.reid@landanddesign.com>
Sent: Wednesday, September 30, 2015 8:48:44 AM
Subject: Fwd: Site C - Add service request for RK Engineering tasks

Hi Alana,

Attached is the scope of work for the added services to the AECOM contract for the Site "C" addendum. Please coordinate with Jane Chang at AECOM and Matt Reid to amend the agreements and to secure the deposit.

Thanks!

Maria Parra

Urban Planner
City of Garden Grove | Planning Services Division
11222 Acacia Parkway, Garden Grove, CA 92840
(714) 741-5312 | (714) 741-5578 fax
mariap@ci.garden-grove.ca.us | www.ci.garden-grove.ca.us

Community Development Department of the City of Garden Grove
"Providing Quality Services Through Creativity and Collaboration"

City Hall Hours:

Monday-Thursday: 7:30 a.m. to 5:30 p.m.
First Friday of the Month: 7:30 a.m. to 5:00 p.m.

Direct Website Links:

Planning Division
Municipal Code, Title 9, Land Use
Zoning Map