



General Information: 714-741-5307

CITY OF GARDEN GROVE - DEVELOPMENT SERVICES DEPARTMENT

Inspection Requests: 714-741-5332

PERMIT (PAGE 2 of 2)

PROJECT/SITE/BUILDING DESCRIPTION

JOB Address : 13102 PARTRIDGE ST
 Suite : 102
 PERMIT NO. : 29744
 Permit Type : MOB.HOME
 Type : B17
 MOBILE HOME INSTALLATIONS
 Owner : ARESTEGUI
 Applicant : SO-CAL MOBILE HOME SERVICE
 Appl Address : 24889 FIR STREET SUITE B
 MORENO VALLEY, CA 92553
 Phone : 714-924-2038

PROPOSED WORK:

MOBILHOME INSTALLATION

OK 13879

FEEES

Insp Dist	: MB	Plan Check	1
Date	: 08/14/95	Permit	1 100.00
Parcel No	: 10145217 89073009 89073014 89073015 89073023 89073028 89073029 89073030 89073031	Issuance	1 20.00

INSPECTION RECORD

APPROVAL	DATE	INSPECTOR
Pre Inspect	_____	_____
Foundation	_____	_____
Concrete Floor	_____	_____
Reinforcing	_____	_____
Masonry	_____	_____
Roof Shtg	_____	_____
Rough Frame	_____	_____
Insul / Energy	_____	_____
Drywall	_____	_____
Lath	_____	_____
Plas. Brown Ct.	_____	_____
Landscaping	_____	_____
Pre Gunite	_____	_____
Pre Deck	_____	_____
Pre Plaster	_____	_____
Planning Final	_____	_____
Bldg Final	8/15/95 <i>[Signature]</i>	_____
Utility Notified	_____	_____

11 3226 BLDG PERM &	100.00
11 3517 ISSUANCE FEE	20.00
11 3527 BLDG P C FEE	0.00
TOTAL	120.00

AUTHORIZATION

Issued By: *mk* Date 8-14-95

DECLARATION

I certify that I have read this application/permit and state that the information on all pages of this document is correct. I agree to comply with all City and County ordinances and State laws relating to building construction, and hereby authorize representatives of this City and County to enter upon the above mentioned property for inspection purposes.

Applicant's Signature *[Signature]*
 Print Name YVONNE BARNES Date 8-14-95

PLOT PLAN

LOT # 102

Department of Housing
and Community Development
Division of Codes and Standards

Park Name Thunderbird

Address 13102 Partridge

City Garden Grove zip

Applicant So-Cal Mobile Home Service

Address 24889 (B) Fir Ave.

Address Moreno Valley, CA 92553

I THE UNDERSIGNED, AS AN AUTHORIZED REPRESENTATIVE OF THE OWNER OF THIS PARK, HEREBY CERTIFY THAT ANY AND ALL LOT LINES AS SHOWN ON THIS PLOT PLAN ARE TRUE AND ACCURATE AND ARE CLEARLY MARKED ON THE SITE AS REQUIRED BY CALIFORNIA ADMINISTRATIVE CODE, TITLE 25, CHAPTER 2, SECTION 1616.

[Signature]
PARK OWNER/OPERATOR

8/11/95
DATE

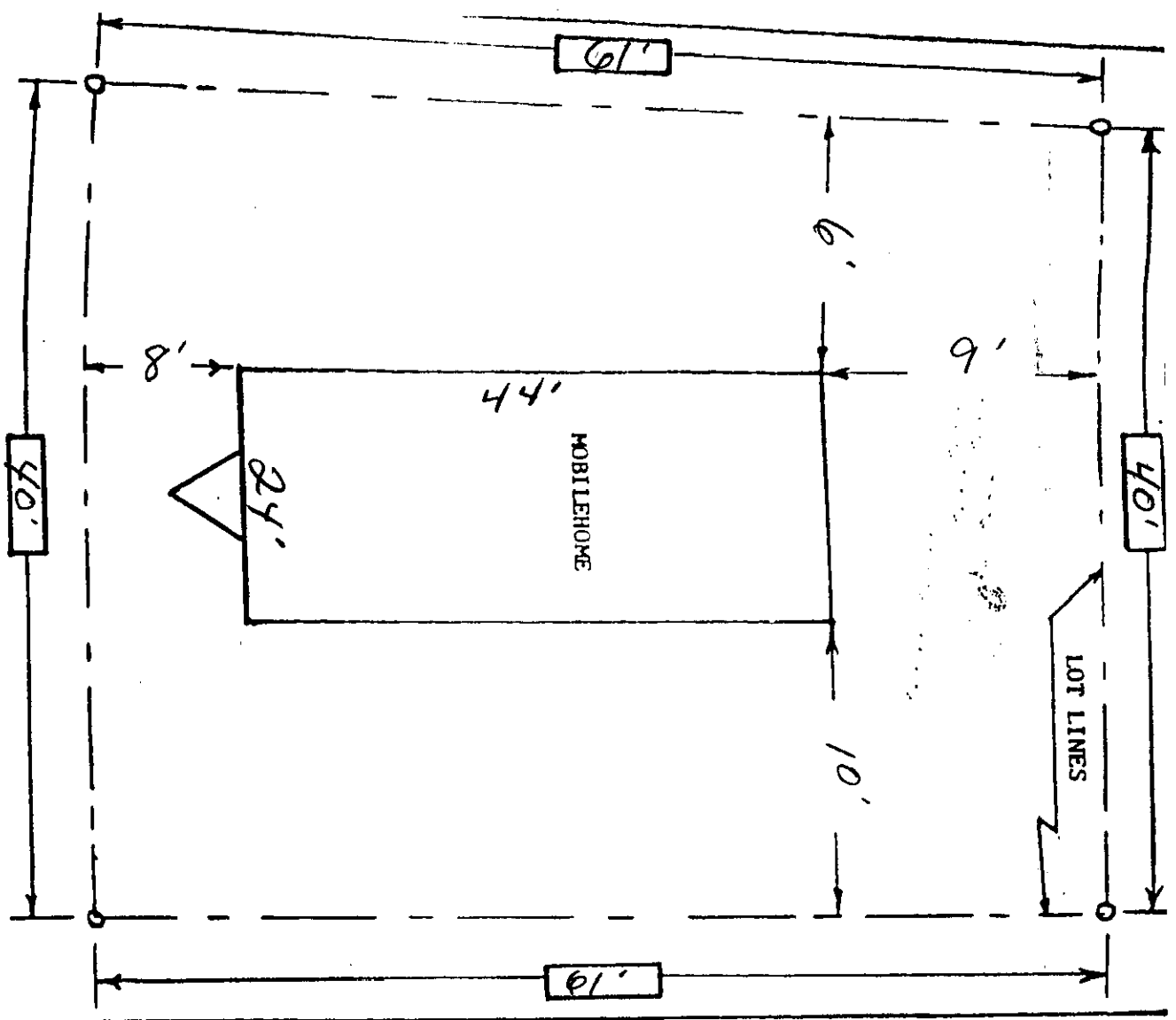

Minimum distance from porch to lot lines shall be 3'-0" except lot lines bordering roadways.

The total occupied area of a mobilehome lot shall not exceed 75% of the lot area.

HCD 538 (Rev. 10-85)

MINUTE MAN ANCHORS, INC. ENGINEERED TIE DOWNS

ENGINEER APPROVAL

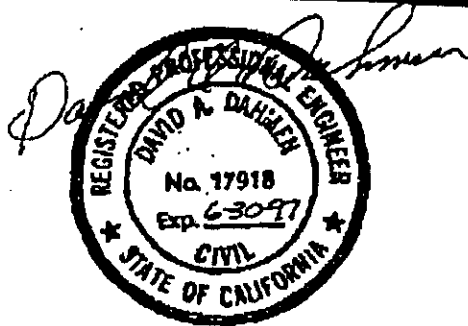

THIS TIEDOWN SYSTEM MEETS THE REQUIREMENTS
OF SEC 1536.3, SUBSECTION (a)

STATE APPROVAL

ENGINEERED TIEDOWN SYSTEM
APPROVED

SUBJECT TO CORRECTIONS NOTED

Approval does not authorize or approve any addition or
deviation from requirements of applicable laws and
regulations.

State of California

Department of Housing and Community Development

DIVISION OF CODES AND STANDARDS

By *[Signature]* Date 02/23/97
(Signature)

SPA NO. E.T.S. - 119

This Plan Approval Expires 02/23/97



PACIFIC CONSULTING ENGINEERS

2200 1st Ave., Suite 105
San Francisco, CA 94102 Phone 415-398-1000

MINUTE MAN ANCHORS, INC.

307 East 10th St. East Port Anch, AK 99701 (907) 882-8500

Design & General Notes

DESIGN LOADS:

WIND 15 PSF
SOIL BEARING 1000 PSF
TIE DOWN STRAPS 3150# WORKING LOAD
SEISMIC ZONE 4

TIE DOWN STRAPS TO BE MIN 1 1/4" WIDE x 0.035 THICKNESS ZINK PLATED &
MEET FEDERAL SPEC QQ-S-701H FOR TYPE 1, CLASS B, GRADE 1, STRAPPING.

EARTH AUGERS 2002# (TESTED TO 4750# MIN.)
CROSS DRIVES 1727# (CALCULATED)
CONCRETE SLAB ANCHORS 1390# (CALCULATED)

GENERAL NOTES:

1. THE CHARTS SHOWN HEREON ARE FOR THE REQUIRED NUMBER OF TIE DOWNS ON THE SIDES OF THE MANUFACTURED HOME.
2. TIE DOWNS ARE REQUIRED AT EACH CHASSIS BEAM, EACH END OF EACH TRANSPORTABLE SECTION OF THE MANUFACTURED HOME AND CAN BE ANY OF THE TYPES SHOWN HEREON.
3. COMBINATIONS OF THE DIFFERENT TYPES OF TIE DOWNS CAN BE USED.
4. IN THE EVENT AN EARTH AUGER CANNOT BE INSTALLED DUE TO AN OBSTRUCTION, USE OF CROSS DRIVE ANCHORS IS PERMITTED, PROVIDED 2 CROSS DRIVES ARE INSTALLED FOR EACH EARTH AUGER THAT CANNOT BE INSTALLED.
5. FOR ALL TIE DOWN INSTALLATIONS, THE MFG'D. HOME CHASSIS MEMBERS ARE SHOWN AS T BEAMS. FOR ILLUSTRATION PURPOSES ONLY, CHASSIS BEAMS CAN ALSO BE C SHAPED OR RFC SHAPED.
6. END TIE DOWNS CAN BE LOCATED W/IN 18" OF EITHER SIDE OF CHASSIS BEAM AXIS AS SHOWN.

CHASSIS BEAM

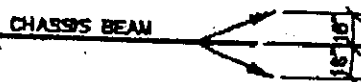

7. THE SIZES, TYPES, LENGTHS, ETC. OF MATERIALS SHOWN HEREON ARE MIN. LARGER, LONGER, HEAVIER MATERIALS SUPPLIED BY MINUTE MAN ANCHORS MAY BE USED AT THE SAME SPACING & LOCATIONS SHOWN.
8. ALL PARTS ARE STAMPED MMA—WITH THE APPROPRIATE PART NUMBER.

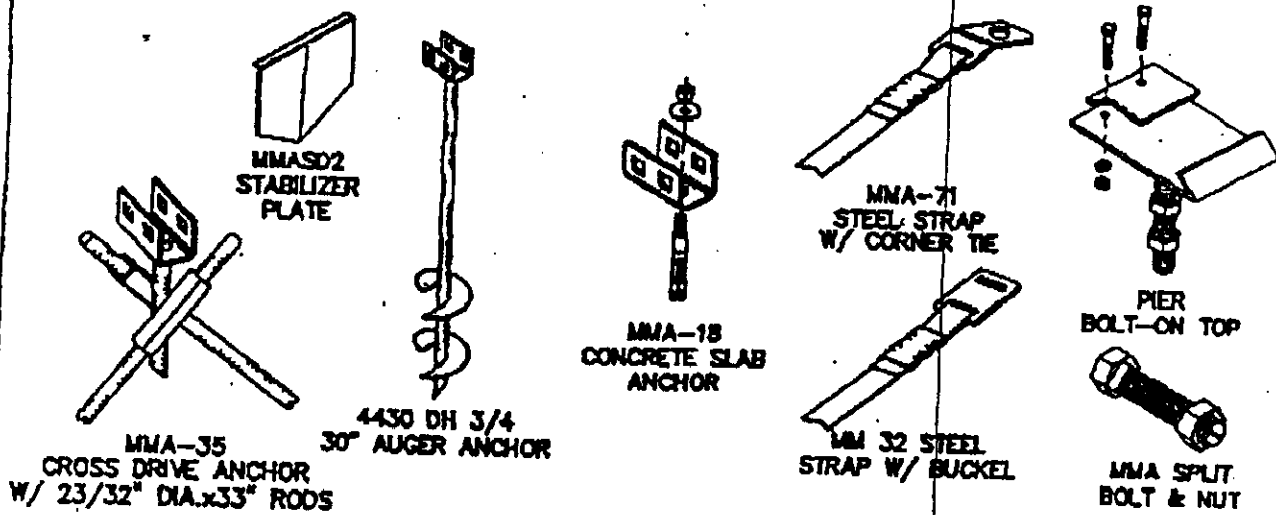

Minute Man Tie Downs

Installation Instructions

FIRST CHECK FOR UNDERGROUND UTILITY LOCATIONS:

EARTH AUGERS

1. INSTALL AUGERS INTO SOIL WITH CONSTANT DOWNWARD PRESSURE TO MINIMIZE SOIL DISTURBANCE, LEAVING APPROX. 12" OF SHAFT EXPOSED.
2. INSTALL STABILIZER PLATE - DRIVE FLUSH W/ GROUND SURFACE.
3. COMPLETE TURNING AUGER INTO GROUND UNTIL AUGER HEAD IS FLUSH W/ GROUND SURFACE & TOP OF STABILIZER PLATE.

CROSS DRIVES

1. CROSS DRIVES ARE USED WHERE HARD OR ROCKY SOIL OCCURS. IF THE GROUND SURFACE IS OTHER THAN ROCK OR MINIMUM 2" ASPHALT, ENCASE THE CROSS DRIVES W/ CONCRETE AS SHOWN IN DETAIL "B".

CONCRETE SLAB ANCHORS

1. CONCRETE SLAB TO MIN. 3 1/2" THICK AND IN GOOD CONDITION.
2. MINIMUM SLAB AREA REQUIRED FOR EACH ANCHOR IS 28 SQ. FT.
3. DRILL PROPER SIZE HOLE IN SLAB MINIMUM 12" FROM ANY EDGE.

ALL APPLICATIONS

1. ATTACH STRAPS TO CHASSIS BEAM IN MANNER SHOWN.
2. INSERT STRAP THROUGH SPLIT NUT. CUT OFF EXCESS STRAP & TIGHTEN UNTIL SNUG.

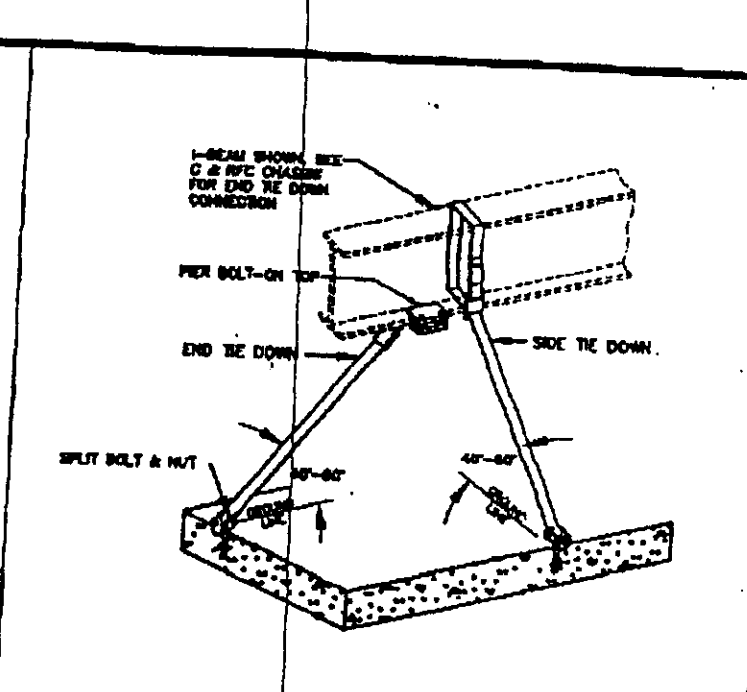
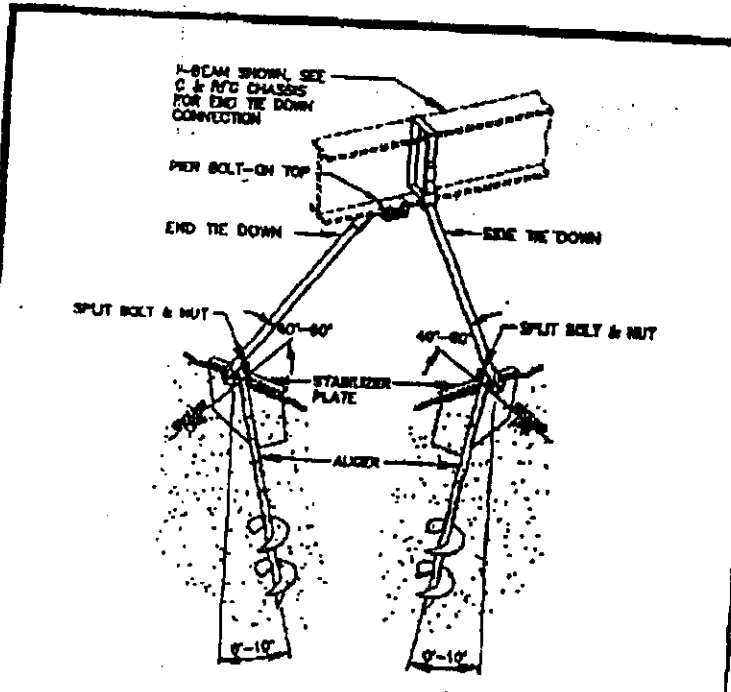

Earth Auger Tie Down

Concrete Tie Down

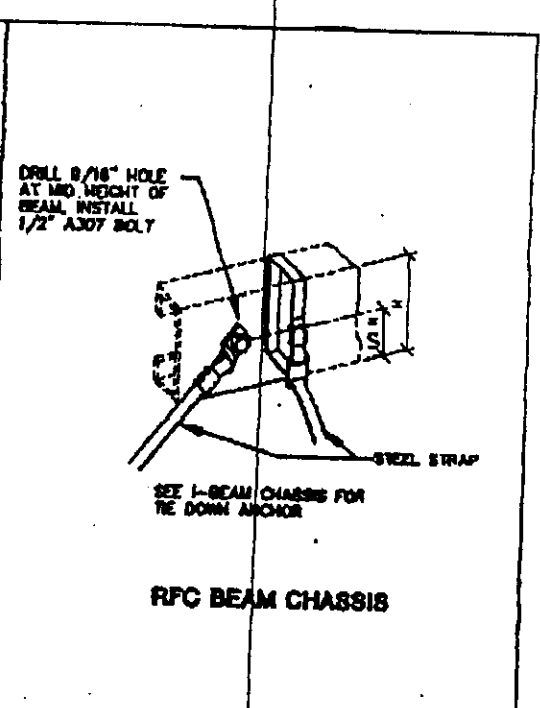
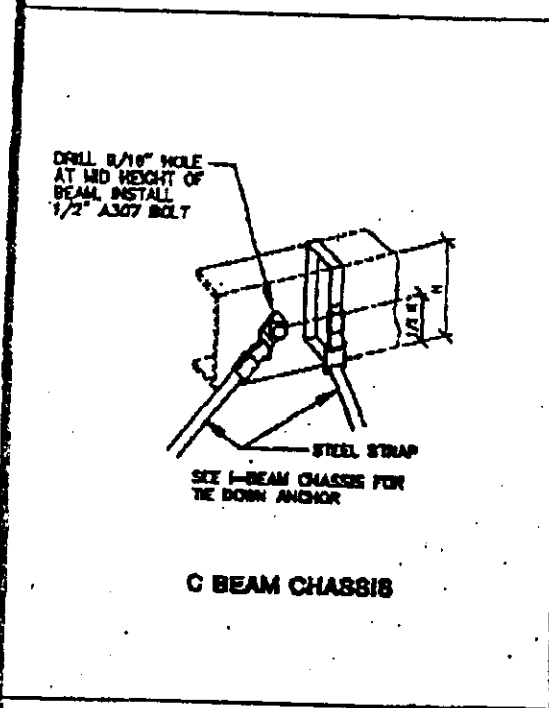

C Beam Chassis

RFC Beam Chassis

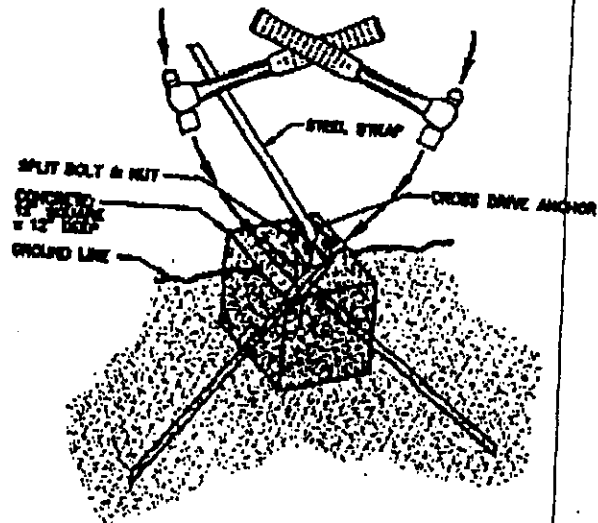
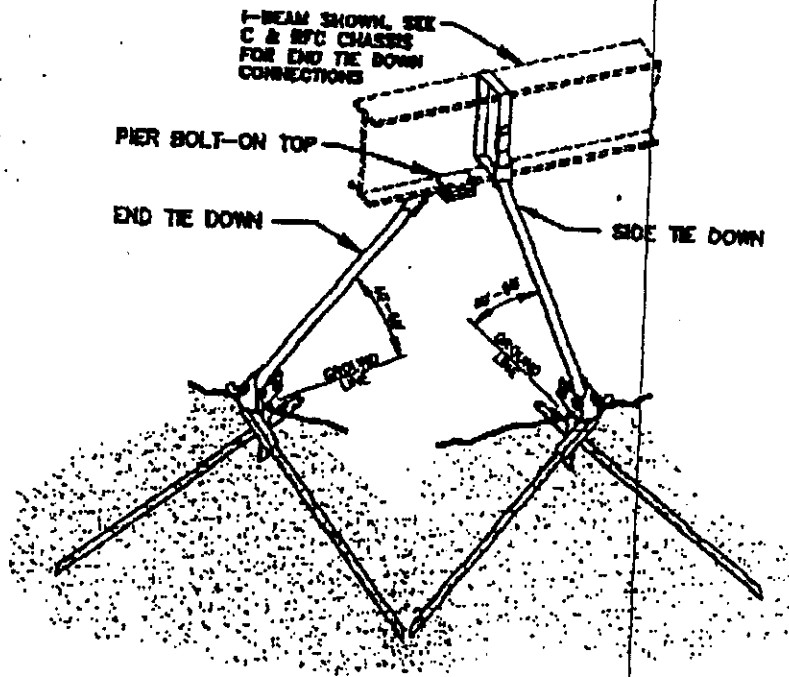

Cross Drive Tie Down

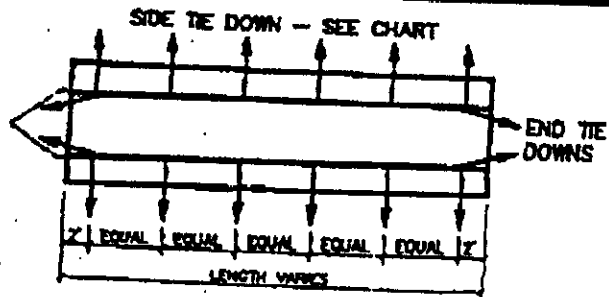

SINGLE WIDE

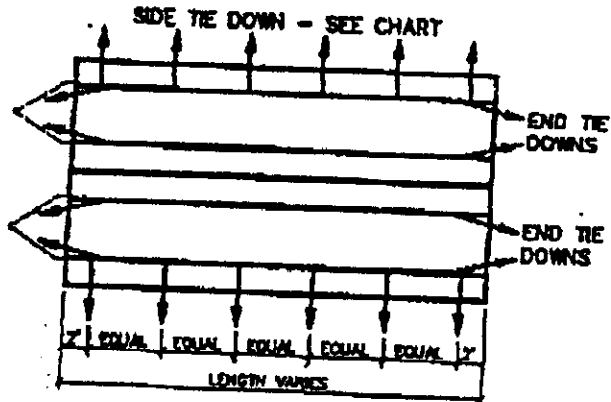

DOUBLE WIDE

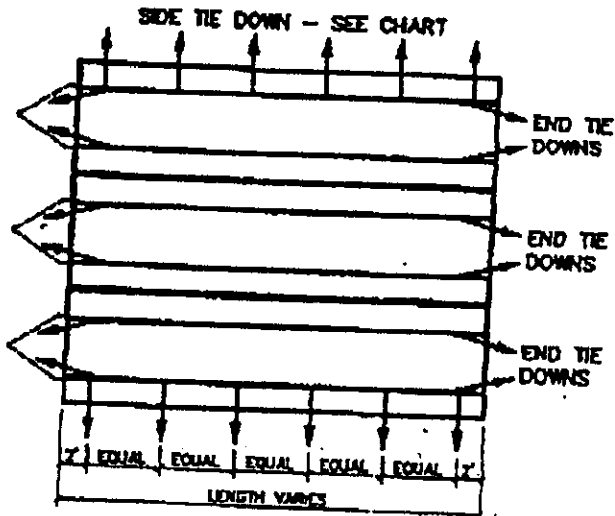

TRIPLE WIDE

EARTH AUGERS

MAX. LENGTH OF MFG'D. HOME	36'	54'	72'		
MIN. NO. OF SIDE TIE DOWNS	2	3	4		

CROSS DRIVE ANCHORS

MAX. LENGTH OF MFG'D. HOME	32'	42'	52'	62'	73'
MIN. NO. OF SIDE TIE DOWNS	3	4	5	6	7

CONCRETE SLAB ANCHORS

MAX. LENGTH OF MFG'D. HOME	34'	42'	50'	58'	66'
MIN. NO. OF SIDE TIE DOWNS	4	5	6	7	8

PLOT PLAN

LOT# 102

Department of Housing
and Community Development
Division of Codes and Standards

Park Name Thunderbird

Address 13102 Partridge

City Garden Grove zip _____

Applicant So-Cal Mobile Home Service

Address 24889 (B) Fir Ave.

Address Moreno Valley, CA 92553

I THE UNDERSIGNED, AS AN AUTHORIZED REPRESENTATIVE OF THE OWNER OF THIS PARK, HEREBY CERTIFY THAT ANY AND ALL LOT LINES AS SHOWN ON THIS PLOT PLAN ARE TRUE AND ACCURATE AND ARE CLEARLY MARKED ON THE SITE AS REQUIRED BY CALIFORNIA ADMINISTRATIVE CODE, TITLE 25, CHAPTER 2, SECTION 1616.

Mae Oels 8/11/95
PARK OWNER/OPERATOR DATE

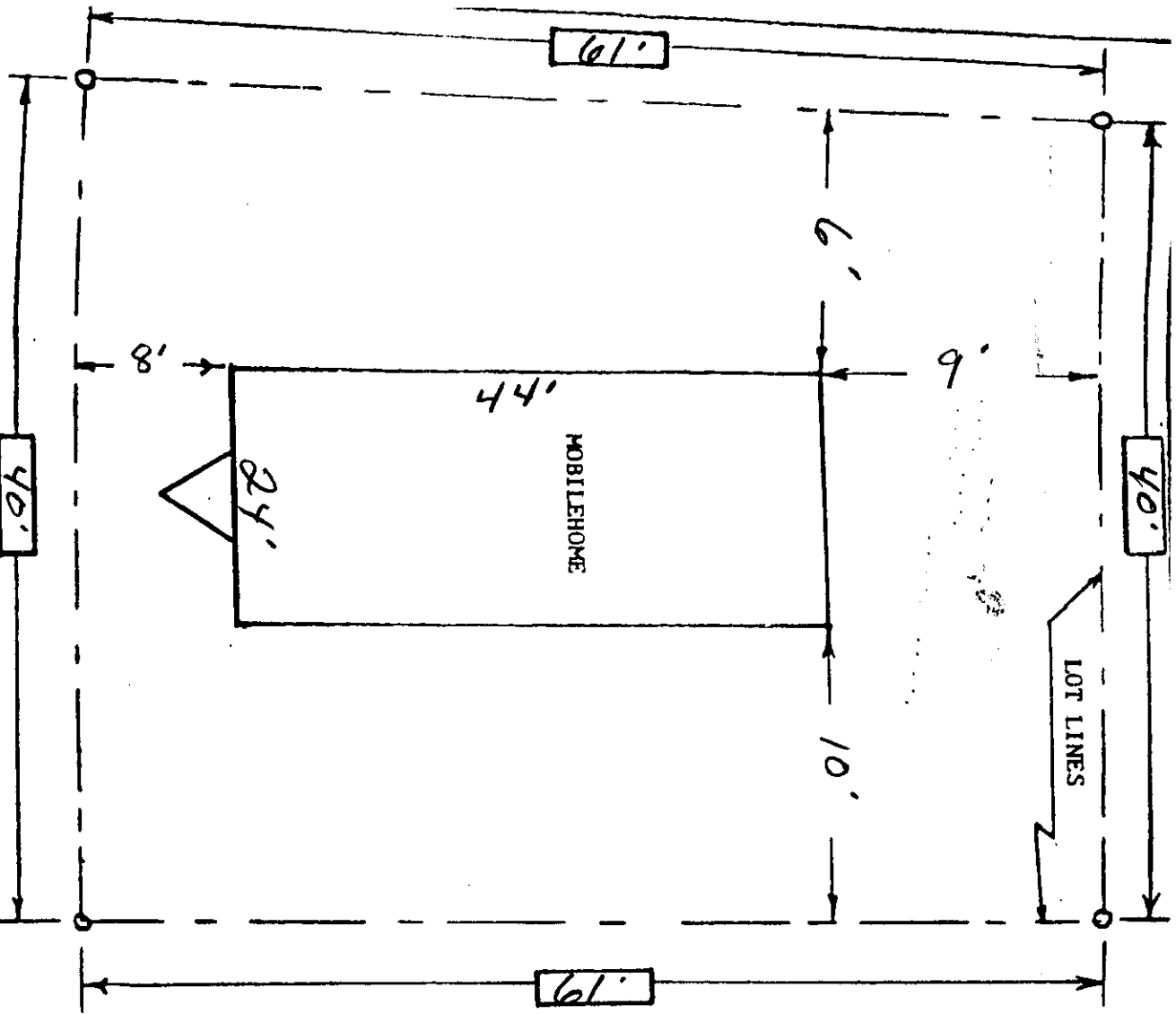

Minimum distance from porch to lot lines shall be 3'-0" except lot lines bordering roadways.

The total occupied area of a mobilehome lot shall not exceed 75% of the lot area.

HCD 538 (Rev. 10-85)



General Information: 714-741-5307

CITY OF GARDEN GROVE - DEVELOPMENT SERVICES DEPARTMENT

Inspection Requests: 714-741-5332

PERMIT (PAGE 2 of 2)

PROJECT/SITE/BUILDING DESCRIPTION

JOB Address : 13102 PARTRIDGE ST
 Suite : 102
 PERMIT NO. : 29782
 Permit Type : MOB.HOME
 Type : B32
 MOBILEHOME ADDITIONS
 Owner : ARESTEGUI
 Applicant : COASTLINE CONSTRUCTION & AWNIN
 Appl Address : 5742-44 RESEARCH DR
 HUNTINGTON BEACH, CA 92649
 Phone : 891-9798

PROPOSED WORK:

10 F.T. X 32 F.T. CARPORT

Insp Dist : MB
 Date : 08/16/95
 Parcel No : 10145217 89073009 89073014 89073015 89073016 89073017 89073018 89073019 89073020 89073021 89073022 89073023 89073024 89073025 89073026 89073027 89073028 89073029 89073030 89073031 89073032 89073033

FEES

Plan Check	1	
Permit	1	30.00
		30.00

INSPECTION RECORD

APPROVAL	DATE	INSPECTOR
Pre Inspect	_____	_____
Foundation	_____	_____
Concrete Floor	_____	_____
Reinforcing	_____	_____
Masonry	_____	_____
Roof Shtg	_____	_____
Rough Frame	_____	_____
Insul / Energy	_____	_____
Drywall	_____	_____
Lath	_____	_____
Plas.Brown Ct.	_____	_____
Landscaping	_____	_____
Pre Gunite	_____	_____
Pre Deck	_____	_____
Pre Plaster	_____	_____
Planning Final	_____	_____
Bldg Final	_____	_____
Utility Notified	_____	_____

11 3226 BLDG PERM &	30.00
11 3517 ISSUANCE FEE	20.00
11 3527 BLDG P C FEE	0.00
TOTAL	50.00

AUTHORIZATION

Issued By: ML Date 8-16-95

DECLARATION

I certify that I have read this application/permit and state that the information on all pages of this document is correct. I agree to comply with all City and County ordinances and State laws relating to building construction, and hereby authorize representatives of this City and County to enter upon the above mentioned property for inspection purposes.

Applicant's Signature [Signature]
 Print Name B.B. Benyick Date 8/16/95

CITY OF GARDEN GROVE
 PLOT PLAN LOT# 102
 Department of Housing and Community Development
 Division of Codes and Standards

Park Name THUNDERBOLT
 Address 13102 PARTRIDGE
 City Garden Grove zip 92643
 Applicant ARISTEGUI
 Address Same

Coastline
Construction & Awning Company, Inc.
 5742-44 Research Dr.
 Huntington Beach, CA 92649
 (714) 891-9798
 FAX (714) 891-9282
 License No. B. C47-C61/D03-601721

I THE UNDERSIGNED, AS AN AUTHORIZED REPRESENTATIVE OF THE OWNER OF THIS PARK, HEREBY CERTIFY THAT ANY AND ALL LOT LINES AS SHOWN ON THIS PLOT PLAN ARE TRUE AND ACCURATE AND ARE CLEARLY MARKED ON THE SITE AS REQUIRED BY CALIFORNIA ADMINISTRATIVE CODE, TITLE 25, CHAPTER 2, SECTION 1616.

Spain Fisher
 PARK OWNER/OPERATOR
 DATE 8-14-95

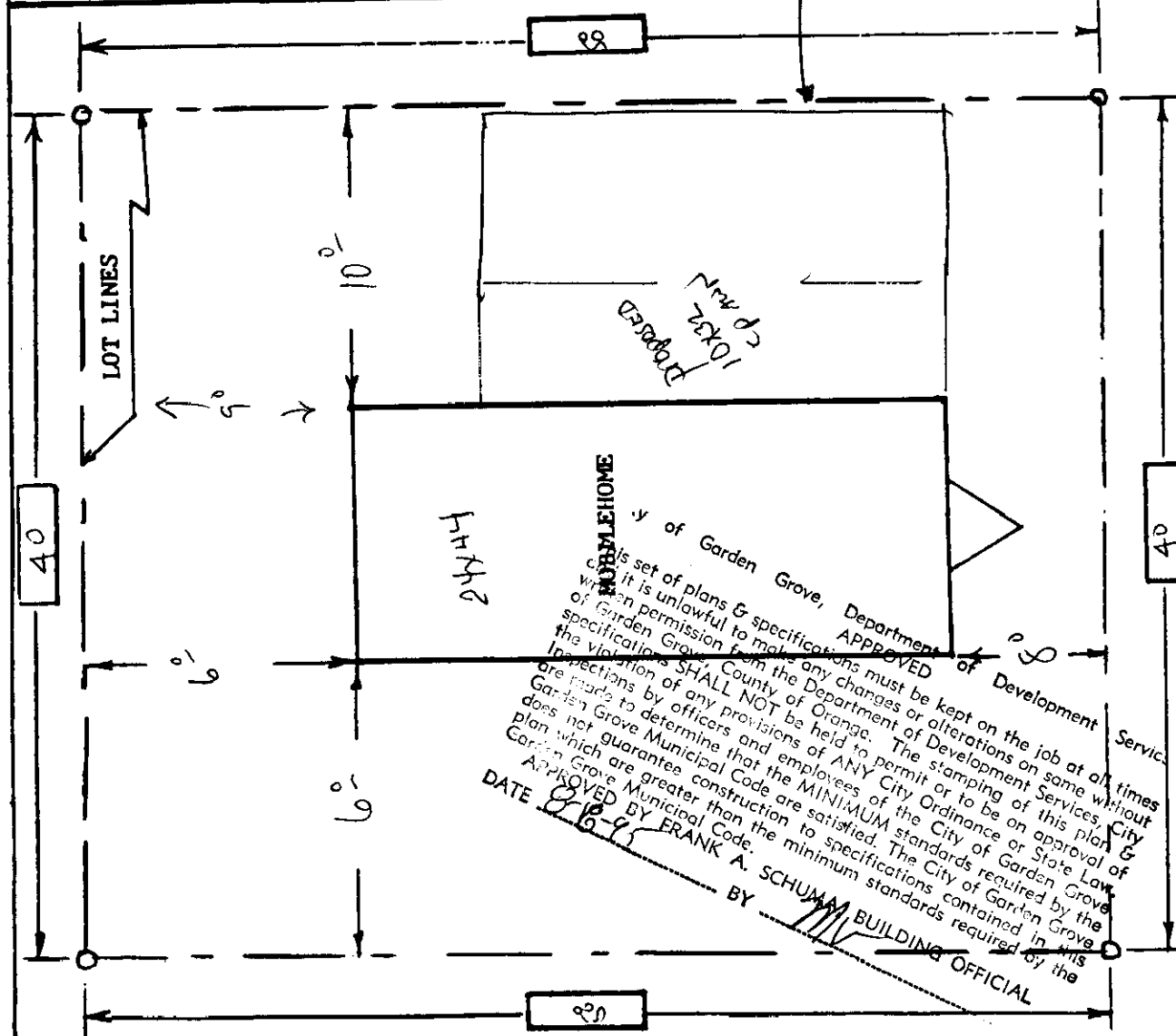

The total occupied area of a mobilehome lot shall not exceed 75% of the lot area.

Minimum distance from porch to lot lines shall be 3'-0" except lot lines bordering driveways.
 HCD 538 (Rev. 10-85)

81.65 7.50



General Information: 714-741-5307

CITY OF GARDEN GROVE - DEVELOPMENT SERVICES DEPARTMENT

Inspection Requests: 714-741-5332

PERMIT (PAGE 2 of 2)

PROJECT/SITE/BUILDING DESCRIPTION

JOB Address : 13102 PARTRIDGE ST
 Suite :
 PERMIT NO. : 85132
 Permit Type : BUILDING
 Type : B33
 REPAIRS
 Owner :
 Applicant : JAY MOREAN
 Phone : 738-5848
 Contractor : GREAT WESTERN ROOFING
 Address : 205 S. BERKELEY CIRCLE
 CityStZip : FULLERTON, CA 92831
 Phone : 738-5848
 Insp Dist : S13
 Date : 05/10/06
 Parcel No : 10145217 89073001 89073002 89073003 89073004 89073005 89073006 89073007 89073008 89073009 89073010 89073011 89073012 89073013
 Value : 1800
 Floor area : 0

PROPOSED WORK:

022 - REROOF

(LAUNDRYROOM) T/O CAPSHEET INSTALL 1 LAY ER
15# FELT & 20YR COMP

FEES

111 32410 Permit	1	80.58
111 32401 issuance	1	35.00
080 32550 Cultural Arts	1	1.70
TOTAL		120.73

APPROVAL	DATE	INSPECTOR
Pre Inspect	5/11/06	AGe
Foundation		
Concrete Floor		
Reinforcing		
Masonry		
Roof Shtg		
Rough Frame		
Insul / Energy		
Drywall		
Lath		
Plas. Brown Ct.		
Landscaping		
Pre Gunite		
Pre Deck		
Pre Plaster		
Planning Final		
Bldg Final	5/15/06	AGe
Utility Notified		

AUTHORIZATION

Issued By: carlosp Date

DECLARATION

I certify that I have read this application/permit and state that the information on all pages of this document is correct. I agree to comply with all City and County ordinances and State laws relating to building construction, and hereby authorize representatives of this City and County to enter upon the above mentioned property for inspection purposes.

Applicant's Signature Jay Morean
 Print Name JAY MOREAN Date 5-10-06

***** VALIDATION *****
 PAID ON 10 May 2006 AT 08:39
 RECEIVED BY KATRENAS 198.245.206.215/2 TRANS# 12
 AMOUNT PAID \$120.73 BY CHECK#2113
 TOTAL PAID = \$120.73



General Information: 714-741-5307

CITY OF GARDEN GROVE - DEVELOPMENT SERVICES DEPARTMENT

Inspection Requests: 714-741-5332

PERMIT (PAGE 2 of 2)

PROJECT/SITE/BUILDING DESCRIPTION

JOB Address : 13102 PARTRIDGE ST
 Suite : 29
 PERMIT NO. : 64045
 Permit Type :
 Type : H

Owner : SANDY EMERY
 Applicant : MC KENNA'S AIR SUPPLY
 Appl Address : 167 N BARNWELL
 OCEANSIDE, CA 92054
 Phone : 760 721 8888

PROPOSED WORK:

C/O FURNACE

Insp Dist : S13
 Date : 09/16/02
 Parcel No : 89073905 89073086 89073080 10145217 89073008 89073014 89073016 89073023 89073028

FEES

GENERAL PLAN		
080 32550 CULTURAL ARTS	1	1.00
111 32401 Issuance	1	35.00
111 32418 FURNACE TO 100000 BT	1	18.00
TOTAL		56.00

APPROVAL DATE INSPECTOR INSPECTION RECORD

Furnace _____
 Furnace Vents _____
 Gas Piping _____
 Ducts _____
 Duct Fan Vent _____
 Kitchen Hood _____
 Air Handl Unit _____
 Evap Cooler _____
 Boiler Comp _____
 Decor Appl _____

~~FINAL~~ *Cancelled 9-17-02*

Utility Notified _____

***** VALIDATION *****
 PAID ON 16 Sep 2002 AT 11:20
 RECEIVED BY JENNP 198.245.206.215/2 TRANS# 51
 AMOUNT PAID \$56.00 BY CHECK#1363
 TOTAL PAID = \$56.00

AUTHORIZATION

Issued By: janetw Date _____

DECLARATION

I certify that I have read this application/permit and state that the information on all pages of this document is correct. I agree to comply with all City and County ordinances and State laws relating to building construction, and hereby authorize representatives of this City and County to enter upon the above mentioned property for inspection purposes.

Applicant's Signature *[Signature]*

Print Name Vanessa McKen Date 9/16/02



General Information: 714-741-5307

CITY OF GARDEN GROVE - DEVELOPMENT SERVICES DEPARTMENT

Inspection Requests: 714-741-5332

PERMIT (PAGE 2 of 2)

PROJECT/SITE/BUILDING DESCRIPTION

JOB Address : 13102 PARTRIDGE ST
 Suite :
 PERMIT NO. : 63796
 Permit Type : BUILDING
 Type : B33
 REPAIRS
 Owner : SIERRA MANAGEMENT
 Applicant : UNI WORLD ROOFING & PAINTING
 Appl Address : 11661 CARDINAL CIR
 GARDEN GROVE, CA 92843
 Phone : 491-7558

PROPOSED WORK:

T/O, REROOF OVER CELOTEX, 1/2" CDX PLYWOOD, AND 30YR COMP SHINGLES

Insp Dist : S13
 Date : 08/28/02
 Parcel No : 89073905 89073086 89073080 101452171 89073009 89073014 89073016 89073023 89073028

FEEES

Value : 2600
 Floor area : 1800

111 32401 issuance	1	35.00
942 22130 General Plan	1	4.39
080 32550 Cultural Arts	1	2.16
TOTAL		148.91

INSPECTION RECORD

APPROVAL	DATE	INSPECTOR
Pre Inspect	8-30-02	Davey
Foundation		
Concrete Floor		
Reinforcing		
Masonry		
Roof Shtg		
Rough Frame		
Insul / Energy		
Drywall		
Lath		
Plas. Brown Ct.		
Landscaping		
Pre Gunit		
Pre Deck		
Pre Plaster		
Planning Final		
Bldg Final	9-24-02	Davey
Utility Notified		

AUTHORIZATION

Issued By: valq _____ Date _____

DECLARATION

I certify that I have read this application/permit and state that the information on all pages of this document is correct. I agree to comply with all City and County ordinances and State laws relating to building construction, and hereby authorize representatives of this City and County to enter upon the above mentioned property for inspection purposes.

Applicant's Signature _____

Print Name Young Soo Yoon Date 8-28-02

***** VALIDATION *****
 PAID ON 28 Aug 2002 AT 11:09
 RECEIVED BY CAROLE 198.245.206.215/2 TRANS# 41
 AMOUNT PAID \$148.91 BY CHECK#2379
 TOTAL PAID = \$148.91



General Information: 714-741-5307

CITY OF GARDEN GROVE - DEVELOPMENT SERVICES DEPARTMENT

Inspection Requests: 714-741-5332

PERMIT (PAGE 2 of 2)

PROJECT/SITE/BUILDING DESCRIPTION

JOB Address : 13102 PARTRIDGE ST
 Suite :
 PERMIT NO. : 64144
 Permit Type : BUILDING
 Type : B33
 REPAIRS
 Owner : THUNDERBIRD MPH
 Applicant : TOTAL SERVICE OF AMERICA
 Appl Address : 2111 SO BROADWAY #202
 LOS ANGELES, CA 90007
 Phone : 213-747-1001

PROPOSED WORK:

REPLACE 13 WINDOWS & 2 SLICERS

Insp Dist : S13
 Date : 09/23/02
 Parcel No : 89073905 89073086 89073080 101452171 89073009 89073014 89073016 89073023 89073028

FEES

Value : 6000
 Floor area : 0

111 32401 issuance	1	35.00
942 22130 General Plan	1	8.38
080 32550 Cultural Arts	1	4.13
TOTAL		195.41

INSPECTION RECORD

APPROVAL	DATE	INSPECTOR
Pre Inspect		
Foundation		
Concrete Floor		
Reinforcing		
Masonry		
Roof Shtg		
Rough Frame		
Insul / Energy		
Drywall		
Lath		
Plas. Brown Ct.		
Landscaping		
Pre Gunit		
Pre Deck		
Pre Plaster		
Planning Final		
Bldg Final	9-27-02	Lawry
Utility Notified		

AUTHORIZATION

Issued By: valq Date

DECLARATION

I certify that I have read this application/permit and state that the information on all pages of this document is correct. I agree to comply with all City and County ordinances and State laws relating to building construction, and hereby authorize representatives of this City and County to enter upon the above mentioned property for inspection purposes.

Applicant's Signature

Print Name SOON J. KIM Date 9-23-02

***** VALIDATION *****
 PAID ON 23 Sep 2002 AT 11:44
 RECEIVED BY JENNP 198.245.206.215/2 TRANS# 106
 CASH PAID = \$200.00 CASH RETURNED = \$4.59
 TOTAL PAID = \$195.41



General Information: 714-741-5307

CITY OF GARDEN GROVE - DEVELOPMENT SERVICES DEPARTMENT

Inspection Request: 714-741-5332

PERMIT (PAGE 2 of 2)

PROJECT/SITE/BUILDING DESCRIPTION

JOB Address : 13102 PARTRIDGE ST
 Suite :
 PERMIT NO. : 64439
 Permit Type :
 Type : E

Owner :
 Applicant : HIGH ELECTRICAL PERFORMANCE
 Appl Address : 15425 TETLEY ST
 HACIENDA HEIGHTS, CA 91745
 Phone : 213 361 3074

PROPOSED WORK:

ELECTRIC TO ROOF EQUIPMENT

Insp Dist : ZE
 Date : 10/09/02
 Parcel No : 89073905 89073086 89073080 10145217 89073008 89073014 89073016 89073023 89073028

FEES

080 32550	CULTURAL ARTS	1	1.00
111 32401	Issuance	1	35.00
111 32412	PWR APPOR 10-50 HP	1	25.00
TOTAL			63.00

APPROVAL DATE INSPECTOR

INSPECTION RECORD

Underground _____
 Conduit _____
 Wiring - Rough _____
 Heater _____
 Fixtures & Trim _____
 Motors _____
 Ufer _____
 Service _____

FINAL 10.15.02 T.H

Utility Notified _____

AUTHORIZATION

Issued By: janetw Date _____

DECLARATION

I certify that I have read this application/permit and state that the information on all pages of this document is correct. I agree to comply with all City and County ordinances and State laws relating to building construction, and hereby authorize representatives of this City and County to enter upon the above mentioned property for inspection purposes.

Applicant's Signature _____

Print Name NICOLA B MUSAT Date 10/9/02

***** VALIDATION *****
 PAID ON 09 Oct 2002 AT 14:28
 RECEIVED BY KRISTINB 198.245.206.215/2 TRANS# 12
 AMOUNT PAID \$63.00 BY CHECK#747
 TOTAL PAID = \$63.00



General Information: 714-741-5307

CITY OF GARDEN GROVE - DEVELOPMENT SERVICES DEPARTMENT

Inspection Requests: 714-741-5332

PERMIT (PAGE 2 of 2)



PROJECT/SITE/BUILDING DESCRIPTION

PROPOSED WORK:

JOB Address : 13102 PARTRIDGE ST
 Suite :
 PERMIT NO. : 97812
 Permit Type :
 Type : E

TEMPORARY POWER POLE & SUBPANEL

Owner :
 Applicant : BRANDY MC GUIRE
 Phone : 765-7551

Contractor : POWER PLUS TEMP.UTILITY SERV.
 Address : 1005 N. EDWARDS CT
 CityStZip : ANAHEIM, CA 92806
 Phone : 764-0020

FEES

Insp Dist : ZE	111 32401 Issuance	1	35.00
Date : 04/24/09	111 32412 SUB-PANEL	1	30.00
Parcel No : 10145217 89073001 89073002 89073003 89073004 89073005 89073006 89073007 89073008 89073009 89073010 89073011 89073012 89073013			
	TOTAL		125.00

APPROVAL DATE INSPECTOR

Underground _____
 Conduit _____
 Wiring - Rough _____
 Heater _____
 Fixtures & Trim _____
 Motors _____
 Ufer _____
 Service 4-29-09 T.H.

FINAL 4-29-09 T.H.
 Utility Notified 4/29/09 JC

AUTHORIZATION

Issued By: joannec Date _____

DECLARATION

I certify that I have read this application/permit and state that the information on all pages of this document is correct. I agree to comply with all City and County ordinances and State laws relating to building construction, and hereby authorize representatives of this City and County to enter upon the above mentioned property for inspection purposes.

Applicant's Signature Brandy

Print Name BRANDY M/GUIRE Date 2/24/09

***** VALIDATION *****

PAID ON 24 Apr 2009 AT 11:28
 RECEIVED BY EDWARDM 198.245.206.215 TRANS# 30785
 AMOUNT PAID \$125.00 BY CHECK
 TOTAL PAID = \$125.00

EMAE - Mahyar (140) 240-4278

City: GARDEN GROVE

799 A-6

N
W + E
S

