

Mr. Mayor and City Council

Tonight, The City is looking for authorization for the:

PURCHASE OF "HOT RED" MOBILE RADIOS AND "the" APPROVAL OF THE AMENDMENT TO THE JOINT AGREEMENT FOR OPERATION, MAINTENANCE AND FINANCIAL MANAGEMENT OF THE ORANGE COUNTY 800 MEGAHERTZ COUNTYWIDE COORDINATED COMMUNICATION SYSTEM

In 2005, parties which included the City of Garden Grove, executed a document entitled Joint Agreement for Operation, Maintenance and Financial Management of the Orange County 800 Megahertz Countywide Coordinated Communication System, which provides for the management and governance of the 800 MHz Countywide Coordinated Communications System. This system is utilized countywide by Police, Fire, Public Works, and other public agencies.

The current 800 MHz Radio System, is becoming obsolete and unsustainable. In response, to ensure future continued operation, Orange County Communications is planning for an extension and upgrade to the countywide "backbone" of the 800MHz radio system. However, with this improvement many of the older radios, approximately 75%, will no longer function on the upgraded "backbone" requiring that all future radios be Project 25 (P25) compliant, which is the latest generation.

The proposed purchase of "Hot Red" radios and the proposed Amendment to the Agreement will allow the County to make necessary upgrades to the 800 MHz Radio System, which will improve performance and extend the working life of the system. Once these improvements are made to the system, it has an expected life span of ten to fifteen additional years of operation past the 2018-19 improvements.

Approval of the attached agreement will, also allow for participation in the countywide

finance option. The City's cost share responsibility will be based upon the number of subscriber radios used on the 800 MHz Radio System, as the City's proportionate share of the System Extension. If the City does not participate in the finance option, the City will have to pay its total cost share in five fiscal year payments beginning in fiscal year 2014-15 through fiscal year 2018-19.

If the City participates in the finance option the cost will be spread over the term of the finance period that has yet to be determined (10-15 years) for the total financed cost of approximately \$4,633,973.

It is recommended that the City Council:

- Approve the purchase of "Hot Red" radios in the 2015-16 budget, in the amount of \$634,468;

- Approve the First Amendment to the Joint Agreement for Operation, Maintenance and Financial Management of the Orange County 800 Megahertz Countywide Coordinated Communication System;
- Authorize the Mayor to sign and execute the Agreement, including making any modifications during the contract period on behalf of the City; and
- Authorize the City Manager to sign and execute all related agreements and documents with regards to the countywide pooled financing arrangement.

This concludes my report. Staff is available for questions.

Zimbra

davidba@ci.garden-grove.ca.us

Re: Traffic Issues

From : David Barlag <davidba@ci.garden-grove.ca.us>

Tue, Mar 10, 2015 01:27 PM

Subject : Re: Traffic Issues**To :** Steve Osborne <sosborne@ggusd.us>

Great,

So the morning it is, we can come to your location, what time works best?

I will send out an invite once we have a time and location.

From: "Steve Osborne" <sosborne@ggusd.us>**To:** "David Barlag" <davidba@ci.garden-grove.ca.us>**Sent:** Tuesday, March 10, 2015 11:01:03 AM**Subject:** RE: Traffic Issues

Evening would be 6:00

Frankly, I think the morning is better, especially since you mentioned that evenings are a problem on your end. It is better for the school to meet in the morning and if you are saying more of the City representatives are available I am fine with that. If we have two parents from the PTSA Board represent our parent interests I think they can be represented very well in that manner. So... whatever works best for you-

Thanks!

From: David Barlag [mailto:davidba@ci.garden-grove.ca.us]**Sent:** Tuesday, March 10, 2015 10:48 AM**To:** Steve Osborne**Subject:** Re: Traffic Issues

Steve, when you say evening, what time are we talking, because this could be problem on our end.

From: "Steve Osborne" <sosborne@ggusd.us>**To:** "David Barlag" <davidba@ci.garden-grove.ca.us>**Sent:** Tuesday, March 10, 2015 10:43:36 AM**Subject:** RE: Traffic Issues

Hello David,

The morning of the 24th or the evening of the 24th would be best. If it is in the evening all five PTSA Board members can attend. If it is more convenient to pull all of the groups together in the morning we will have two parents who can represent everyone and they are fine with the morning also.

Thank you,
Steve

From: David Barlag [<mailto:davidba@ci.garden-grove.ca.us>]
Sent: Wednesday, March 04, 2015 3:23 PM
To: Steve Osborne
Subject: Re: Traffic Issues

Mr. Osborne,
So in checking with my participants the 23rd or 24 will work best for us.
Thanks again.

From: "David Barlag" <davidba@ci.garden-grove.ca.us>
To: sosborne@ggusd.us
Cc: "Adam Zmija" <adamz@ci.garden-grove.ca.us>, "Tony Aquino" <tony1@ci.garden-grove.ca.us>
Sent: Wednesday, March 4, 2015 11:27:30 AM
Subject: Traffic Issues

Mr. Osborne,
It was nice meeting with you this morning.
Please put together your group of contributing parties for a joint discussion and we will bring in Police Dept. Traffic, and Traffic Engineering to discuss, what has been done and what else we can do, to make the streets as safe as possible. Let's shoot for the week of March 23 as a target date.
Look forward to hearing back from you.

--

David R. Barlag
City Manager's Office
City of Garden Grove
(714) 741-5994

--

David R. Barlag
City Manager's Office
City of Garden Grove
(714) 741-5994

CONFIDENTIALITY NOTICE: This e-mail and any attachments may contain non-public, confidential or legally privileged information. If you are not the intended recipient, you are notified that any unlawful interception, disclosure, printing, copying, distribution or use of the contents is prohibited under the Electronic Communication Privacy Act, 18 USCA 2510, 18 USCA 2511 and any applicable laws. If you received this in error, please notify the sender by reply e-mail and delete this message.

Spam
Not spam
Forget previous vote

--

David R. Barlag
City Manager's Office
City of Garden Grove
(714) 741-5994

CONFIDENTIALITY NOTICE: This e-mail and any attachments may contain non-public, confidential or legally privileged information. If you are not the intended recipient, you are notified that any unlawful interception, disclosure, printing, copying, distribution or use of the contents is prohibited under the Electronic Communication Privacy Act, 18 USCA 2510, 18 USCA 2511 and any applicable laws. If you received this in error, please notify the sender by reply e-mail and delete this message.

NOTE: This message was trained as non-spam. If this is wrong, please correct the training as soon as possible.

Spam
Not spam
Forget previous vote

--

David R. Barlag
City Manager's Office
City of Garden Grove
(714) 741-5994

Zimbra

davidba@ci.garden-grove.ca.us

Design Build Overview Fire Station 6

From : David Barlag <davidba@ci.garden-grove.ca.us>

Tue, Mar 10, 2015 01:37 PM

Subject : Design Build Overview Fire Station 6

To : susan1@ci.garden-grove.ca.us

The following meeting has been modified:

Subject: Design Build Overview Fire Station 6

Organizer: "David Barlag" <davidba@ci.garden-grove.ca.us>

Location: "CH3_Training" <ch3_training@ci.garden-grove.ca.us>

Time: Wednesday, March 11, 2015, 10:30:00 AM - 12:00:00 PM (GMT-0800)
GMT-08.00/-07.00

Invitees: allanr@ci.garden-grove.ca.us; ch3_training@ci.garden-grove.ca.us;
gchubb@griffinholdings.net; kingsley@ci.garden-grove.ca.us; nathanb@ci.garden-grove.ca.us; osandoval@wss-law.com; philc@ci.garden-grove.ca.us;
rtorriero@griffinholdings.net; sandras@ci.garden-grove.ca.us; warrenh@ci.garden-grove.ca.us; wem@ci.garden-grove.ca.us ...

~~*~*~*~*~*~*~*~*

Immediately following the completion of Central Management, Griffin Structures is going to present an overview of the "Design Build Process". Griffin served as the project manager for the Tustin Fire Station #37 that some of us have seen. This should give us all an expectation of what will be needed going forward for Fire Station #6. They will move in as soon as the Central Management meeting is complete.

David R. Barlag
714 741-5994

Zimbra

davidba@ci.garden-grove.ca.us

City of Garden Grove finance request

From : David Barlag <davidba@ci.garden-grove.ca.us>

Tue, Mar 10, 2015 01:51 PM

Subject : City of Garden Grove finance request

To : Kim Caplan <kim.caplan@motorolasolutions.com>

Cc : Kingsley Okereke <kingsley@ci.garden-grove.ca.us>

Kim,

It was nice meeting you the other day at the Governance Meeting.

Can I ask for a quote for Garden Grove with two term lengths and two options for each term.

So I am asking for 4 quotes;

1)10 year term

Console and Equipment

2)10 year term

Console and Equipment plus Backbone

3)15 year term

Console and Equipment

4)15 year term

Console and Equipment plus Backbone

If you need any additional information, let me know.

We are just exploring our options.

Thank you,

--

David R. Barlag
City Manager's Office
City of Garden Grove
(714) 741-5994

Zimbra

davidba@ci.garden-grove.ca.us

Meeting with GGHS

From : David Barlag <davidba@ci.garden-grove.ca.us>

Tue, Mar 10, 2015 02:23 PM

Subject : Meeting with GGHS**To :** Adam Zmija <adamz@ci.garden-grove.ca.us>, Tony Aquino
<tony1@ci.garden-grove.ca.us>

Waiting to hear the time but sometime Tuesday the 24 in the morning we are scheduling a meeting with GGHS.

This meeting will include us,

City Mangers Office

Traffic Engineering

Police Department

Principal

PTA

and other from the School side.

The goal of this meeting is to listen to their concerns, see what is possible and make recommendations from fixes.

All this doesn't have to happen at this meeting, simultaneously but the goal is to make the School and Others feel like they are part of the solution.

I think a big part of my proposed solution will be outreach and communication to parents and students.

--

David R. Barlag
City Manager's Office
City of Garden Grove
(714) 741-5994

Zimbra

davidba@ci.garden-grove.ca.us

Garden Grove High School Traffic Safety

From : David Barlag <davidba@ci.garden-grove.ca.us>

Tue, Mar 10, 2015 04:31 PM

Subject : Garden Grove High School Traffic Safety

To : Adam Zmija <adamz@ci.garden-grove.ca.us>, Tony Aquino <tony1@ci.garden-grove.ca.us>, sosborne <sosborne@ggusd.us>

The following meeting has been modified:

Subject: Garden Grove High School Traffic Safety

Organizer: "David Barlag" <davidba@ci.garden-grove.ca.us>

Location: Garden Grove High School

Time: Tuesday, March 24, 2015, 9:00:00 AM - 10:30:00 AM GMT -08:00 US/Canada Pacific

Invitees: adamz@ci.garden-grove.ca.us; tony1@ci.garden-grove.ca.us; sosborne@ggusd.us

~~*~*~*~*~*~*~*~*

Steve,
Please invite other stakeholders as you see fit.
Thanks,

David Barlag

Zimbra

davidba@ci.garden-grove.ca.us

Garden Grove High School Traffic Safety

From : David Barlag <davidba@ci.garden-grove.ca.us>

Tue, Mar 10, 2015 04:45 PM

Subject : Garden Grove High School Traffic Safety**To :** Allan Roeder <allanr@ci.garden-grove.ca.us>, Bill Murray
<wem@ci.garden-grove.ca.us>, Todd Elgin
<todde@ci.garden-grove.ca.us>

Just an FYI,

I have scheduled a Stakeholders meeting with Garden Grove High School regarding traffic safety.

We will meet 3/24/2015 at 9:00 am at the school site.

Attendees are;

David Barlag, CM Office
Adam Zmija, Neighborhood Traffic Unit
Tony Aquino, Traffic Engineer
Steve Osborne, Principal
PTSA Board Representaives

The purpose of this meeting is to explain the situation as we know it, show what has been done, see what is desired and explore options moving forward.

--

David R. Barlag
City Manager's Office
City of Garden Grove
(714) 741-5994

Zimbra

davidba@ci.garden-grove.ca.us

Fwd: GGFS No. 6

From : David Barlag <davidba@ci.garden-grove.ca.us>

Wed, Mar 11, 2015 02:04 PM

Subject : Fwd: GGFS No. 6

2 attachments

To : Phil Carter <philc@ci.garden-grove.ca.us>, Bill Murray <wem@ci.garden-grove.ca.us>, Sandra Segawa <sandras@ci.garden-grove.ca.us>, omar sandoval <osandoval@wss-law.com>, Susan Emery <susan1@ci.garden-grove.ca.us>

Group,

Please see the attached from Gary from this mornings meeting.

From: "Gary Chubb" <gchubb@griffinholdings.net>
To: davidba@ci.garden-grove.ca.us
Sent: Wednesday, March 11, 2015 1:19:42 PM
Subject: GGFS No. 6

David,

On behalf of Griffin Structures I want to thank you and the City staff for the opportunity to discuss our recommendations on how to best design and construction Fire Station No. 6. I believe this was a very fruitful discussion and now the various department heads have a much more clear understanding of both the Design-Build process and how to advance the efforts through Council in the next 30-60 days.

As follow-up to our company's information attached is our references for multiple completed projects in the public sector. This handout was inadvertently left out of the package so I thought I would pass this along so you can distribute to those who will benefit from learning our depth of experience in not only public safety related projects but many others of similar size and complexity.

Again thank you for the meeting today and we hope that we can serve the City in the very near future.

Best regards,

**Gary Chubb** | Executive Vice President/Director of Operations
GRIFFIN STRUCTURES, INC.

385 Second Street, Laguna Beach, CA 92651 | T 949-497-9000 x205 | F 949-497-8883 | C 949-413-6890

www.griffinstructures.com P Do you really need to print this email? Please consider our environment.

CONFIDENTIALITY NOTICE: This e-mail transmission, and any documents, files or previous email messages attached to it, may contain confidential information. If you are not the intended recipient, or a person responsible for delivering it to the intended recipient, you are hereby notified that any disclosure, copying, distribution or use of any of the information contained in or attached to this message is STRICTLY PROHIBITED. If you have received this transmission in error, please immediately notify us by reply e-mail at gchubb@griffinholdings.net or by telephone at 949.497.9000 and destroy the original transmission and attachments without reading them or saving them to disk. Thank you. WARNING: This electronic e-mail message is furnished without guarantee of compatibility with recipients' hardware or software and may contain undetected viruses or other damaging material. It is recommended that this e-mail message and any attachments be checked prior to viewing or use. Sender assumes no responsibility for damage to user's equipment or property as a result of receiving this e-mail message and/or using or viewing its contents.

NOTE: This message was trained as non-spam. If this is wrong, please correct the training as soon as possible.

[Spam](#)

[Not spam](#)

[Forget previous vote](#)

--

David R. Barlag
City Manager's Office
City of Garden Grove
(714) 741-5994



image001.jpg
2 KB



Griffin References.pdf
227 KB

Zimbra

davidba@ci.garden-grove.ca.us

Re: Amendment to the Agreement GG

From : David Barlag <davidba@ci.garden-grove.ca.us>
Subject : Re: Amendment to the Agreement GG
To : Marten Miller <Marten.Miller@comm.ocgov.com>

Wed, Mar 11, 2015 02:31 PM

Marten,
One more thing for now, and she may have this but I have several dated complete inventories for GG but Kim is working on a bid for us. Do you have a latest and greatest inventory for GG, Mine is dated Nov of 14.
Thanks

From: "Marten Miller" <Marten.Miller@comm.ocgov.com>
To: "David Barlag" <davidba@ci.garden-grove.ca.us>
Sent: Wednesday, March 11, 2015 2:09:36 PM
Subject: RE: Amendment to the Agreement GG

Great news. Thank you David!

From: David Barlag [mailto:davidba@ci.garden-grove.ca.us]
Sent: Wednesday, March 11, 2015 2:09 PM
To: Miller, Marten
Subject: Amendment to the Agreement GG

Marten,
Just an FYI the amendment carried last night, some I will get you an executed version soon!

--

David R. Barlag
City Manager's Office
City of Garden Grove
(714) 741-5994

NOTE: This message was trained as non-spam. If this is wrong, please correct the training as soon as possible.

[Spam](#)

[Not spam](#)

[Forget previous vote](#)

--

David R. Barlag

City Manager's Office
City of Garden Grove
(714) 741-5994

Zimbra

davidba@ci.garden-grove.ca.us

Re: City of Garden Grove finance request

From : David Barlag <davidba@ci.garden-grove.ca.us> Thu, Mar 12, 2015 11:14 AM
Subject : Re: City of Garden Grove finance request 1 attachment
To : Kim Caplan <Kim.Caplan@motorolasolutions.com>
Cc : Kingsley Okereke <kingsley@ci.garden-grove.ca.us>

Kim,

We confirmed the number that were on the spreadsheet from the County so we can use those numbers as far as totals.

We will be purchasing Hot Reds outright so you can deduct those from the totals. I understand that you cannot do item three.

As far as Hot Reds, I assume the County will be handling that order?

Thanks,
Dave

From: "Kim Caplan" <Kim.Caplan@motorolasolutions.com>
To: "David Barlag" <davidba@ci.garden-grove.ca.us>
Cc: "Kingsley Okereke" <kingsley@ci.garden-grove.ca.us>
Sent: Tuesday, March 10, 2015 7:38:00 PM
Subject: RE: City of Garden Grove finance request

David,

It was nice to meet you as well. Can you please provide me with the following information?

- 1) Do you need exact numbers for the radio equipment or do you just want to use the spreadsheet the County has with their estimates for now? If exact numbers can you please provide portable radio quantities and accessories required. I believe the mobiles are covered in the attached proposal, but if you could please confirm the quantities and that you don't need any non-hot red radios that would be great.
- 2) Same question as #1
- 3) Can only provide a 10 year lease without any backbone for consoles and radios
- 4) Same question as #1

Best Regards,

Kim Caplan
Senior Account Manager

Motorola Solutions, Inc.
O: 760-630-5199
M: 858-442-3979



From: David Barlag [mailto:davidba@ci.garden-grove.ca.us]
Sent: Tuesday, March 10, 2015 1:51 PM
To: Kim Caplan
Cc: Kingsley Okereke
Subject: City of Garden Grove finance request

Kim,

It was nice meeting you the other day at the Governance Meeting.
Can I ask for a quote for Garden Grove with two term lengths and two options for each term.

So I am asking for 4 quotes;

1)10 year term

Console and Equipment

2)10 year term

Console and Equipment plus Backbone

3)15 year term

Console and Equipment

4)15 year term

Console and Equipment plus Backbone

If you need any additional information, let me know.
We are just exploring our options.
Thank you,

--

David R. Barlag
City Manager's Office
City of Garden Grove
(714) 741-5994

NOTE: This message was trained as non-spam. If this is wrong, please correct the training as soon as possible.

[Spam](#)

[Not spam](#)

[Forget previous vote](#)

--

David R. Barlag
City Manager's Office
City of Garden Grove
(714) 741-5994

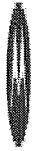

MOTOROLA SOLUTIONS

image001.png
6 KB

Zimbra

davidba@ci.garden-grove.ca.us

Briefing before we meet with GGHS

From : David Barlag <davidba@ci.garden-grove.ca.us>

Thu, Mar 12, 2015 01:17 PM

Subject : Briefing before we meet with GGHS**To :** Tony Aquino <tony1@ci.garden-grove.ca.us>, Adam Zmija
<adamz@ci.garden-grove.ca.us>

Guys,

Is there a better day or time?

I would like to get together to discuss strategy for the meeting.

Can we meet next week some time?

How about Tuesday 3/17/15 9:00 am for now.

We can meet in my office or a conference room near by.

3rd floor near Tom Nixon's Office.

Adam what is your availability?

--

David R. Barlag
City Manager's Office
City of Garden Grove
(714) 741-5994

Zimbra

davidba@ci.garden-grove.ca.us

GGHS Briefing

From : David Barlag <davidba@ci.garden-grove.ca.us>

Thu, Mar 12, 2015 02:12 PM

Subject : GGHS Briefing

To : Tony Aquino <tony1@ci.garden-grove.ca.us>, Adam Zmija
<adamz@ci.garden-grove.ca.us>

The following is a new meeting request:

Subject: GGHS Briefing

Organizer: "David Barlag" <davidba@ci.garden-grove.ca.us>

Location: 3rd Floor City Hall

Time: Tuesday, March 17, 2015, 9:00:00 AM - 10:00:00 AM GMT -08:00 US/Canada Pacific

Invitees: tony1@ci.garden-grove.ca.us; adamz@ci.garden-grove.ca.us

~~*~*~*~*~*~*~*~*

GGHS Strategy Discussion

Zimbra**davidba@ci.garden-grove.ca.us**

Draft Agenda

From : David Barlag <davidba@ci.garden-grove.ca.us>

Thu, Mar 12, 2015 03:39 PM

Subject : Draft Agenda 1 attachment**To** : Adam Zmija <adamz@ci.garden-grove.ca.us>, Tony Aquino
<tony1@ci.garden-grove.ca.us>

Guys,
Here's a draft agenda for the 3/24 meeting,
we can discuss changes on the 3/17 briefing

--

David R. Barlag
City Manager's Office
City of Garden Grove
(714) 741-5994

**GGHS Agenda 32415.docx**19 KB

Garden Grove High School

Agenda 3/24/2015

- Introduction/ sign in contact information
- Purpose
- History
 - The City of Garden Grove received complaints during a City Council meeting.
 - Mr. Craig Durfey

 - Staff was directed to review the situation
 - PD Traffic did a 5 year summary of incidents in the area
 - Master Officer Zmija to discuss
 - Handout (5 year Traffic Incidents)
 - Traffic Engineering review the current signage and street marking
 - Traffic Engineer Tony Aquino to discuss
 - Handouts (Signage Improvements) (Street Markings)

 - The City again received complaints during a City Council meeting
 - ASB Students and Leann Dotson representing

- What can we do next?
 - Awareness
 - Training
 - Stricter Enforcement
 - Physical Barriers

- Follow up

Zimbra

davidba@ci.garden-grove.ca.us

Push back meeting 30 minutes for tomorrow

From : David Barlag <davidba@ci.garden-grove.ca.us>

Mon, Mar 16, 2015 09:46 AM

Subject : Push back meeting 30 minutes for tomorrow**To :** Tony Aquino <tony1@ci.garden-grove.ca.us>, Adam Zmija
<adamz@ci.garden-grove.ca.us>

Can we push back meeting 30 minutes tomorrow start at 9:30 sent new invite, sorry for the short notification, just notified I have a 8:30 to 9:30 meeting.

--

David R. Barlag
City Manager's Office
City of Garden Grove
(714) 741-5994

Zimbra

davidba@ci.garden-grove.ca.us

Garden Grove Amendment to the 800 MHz agreement

From : David Barlag <davidba@ci.garden-grove.ca.us> Wed, Mar 18, 2015 11:12 AM
Subject : Garden Grove Amendment to the 800 MHz agreement 1 attachment
To : Marten Miller <marten.miller@comm.ocgov.com>

Marten,
Attached is an executed copy of GG amendment,
The original will be sent through normal channels through our City Clerk's Office to the
County.

From: katrenas@ci.garden-grove.ca.us
To: "Dave Barlag" <davidba@ci.garden-grove.ca.us>
Sent: Wednesday, March 18, 2015 10:54:57 AM
Subject: Message from "ricoh106"

This E-mail was sent from "ricoh106" (Aficio MP 6001).

Scan Date: 03.18.2015 10:54:56 (-0700)
Queries to: katrenas@ci.garden-grove.ca.us

--

David R. Barlag
City Manager's Office
City of Garden Grove
(714) 741-5994

 **20150318105456624.pdf**
755 KB

**AMENDMENT TO JOINT AGREEMENT
FOR THE OPERATION, MAINTENANCE AND FINANCIAL MANAGEMENT
OF THE ORANGE COUNTY 800 MEGAHERTZ
COUNTYWIDE COORDINATED COMMUNICATIONS SYSTEM**

THIS AMENDMENT (“**Amendment**”) is entered into on _____, 2015 by and between the Parties listed on Exhibit A, attached hereto, which are sometimes individually referred to as “**Party**” or collectively referred to as the “**Parties**.”

RECITALS

A. On November 23, 2004, the Parties executed that certain document entitled *Joint Agreement for the Operation, Maintenance and Financial Management of the Orange County 800 Megahertz Countywide Coordinated Communications System* (“**Agreement**”), which provides for the management and governance of the 800 MHz Countywide Coordinated Communications System (“800 MHz CCCS”).

B. The 800 MHz CCCS requires significant enhancement in order to extend the life of the system.

C. Pursuant to Section 15.10 of the Agreement, the Governance Committee and the County have developed a long-range implementation plan to extend the CCCS, and have developed a scope of work, which includes all the activities, infrastructure and project schedule information for fiscal years 2014-19 described on Exhibit B, attached hereto (“**System Extension**”).

D. The Governance Committee and County have also developed the overall estimated cost of the System Extension, including each Party’s estimated funding share by fiscal year described on Exhibit C, attached hereto.

E. A Party’s funding plan for the System Extension may consist of one or more of the following: 1) a Party’s cash contribution, 2) a Party or a group of Parties financing all or a portion of the System Extension through the issuance of tax exempt bonds or other public financing mechanisms, and/or 3) a Party or group of Parties financing all or a portion of the System Extension through the County approved System Extension vendor.

F. The Parties desire to amend the Agreement to provide their commitment to the System Extension and describe their implementation and funding obligations.

G. This Amendment has been approved by the Governance Committee.

AGREEMENT

NOW, THEREFORE, in consideration of the foregoing recitals and other good and valuable consideration, the receipt and sufficiency of which are hereby acknowledged, the Parties hereby agree as follows:

1. Implementation Obligations. The Parties hereby commit to fund and implement the System Extension as described on Exhibit B and Exhibit C.

a. California Environmental Quality Act ("CEQA"). The County shall be the lead agency for purposes of CEQA and shall obtain all necessary approvals for the System Extension.

b. Party Cost Share. The Parties intend to implement and fund the System Extension over several years beginning in fiscal year 2014-15 through fiscal year 2018-19. Each Party is responsible for its fair share contribution to the System Extension. The total estimated budget for the System Extension and each Party's fair share contribution is depicted on Exhibit C ("**Cost Share**"). A Party's Cost Share is determined by the number of subscriber radios used by the Party on the CCCS, as well as the Party's proportionate share of the System Extension dedicated to System Backbone. Each Party shall pay its total Cost Share in five fiscal year payments beginning in fiscal year 2014-15 through fiscal year 2018-19 in accordance with the procedures in Subsection (c) below. Each Party acknowledges that its Cost Share for the System Extension is an estimate and is expressed as a not to exceed amount. Each Party's Cost Share will be based on an actual quote by a third party vendor who will perform the System Extension under a contract or series of contracts approved and managed by the County ("**Contractor**"). A Party's actual Cost Share amount will be determined prior to the beginning of each fiscal year in which it is due and will be based on the Contractor's scope of work for the respective fiscal year. Therefore, the Cost Share depicted on Exhibit C may change, and may be periodically updated by the Parties to reflect any changed equipment or authorized System Extension modification expenses.

c. Invoicing & Payment. The County will calculate the actual Cost Share amount due the following fiscal year, and will invoice each Party by July 1. Each Party shall pay its respective Cost Share to the County within thirty (30) days of the start of the fiscal year. A Party is exempt from the payment procedures of this Subsection 1.c for the relevant fiscal year if it has:

- i. Executed a binding agreement with the County approved Contractor, agreeing to pay or finance its Cost Share through the Contractor directly, or
- ii. Executed a binding agreement with the County agreeing to jointly finance its Cost Share.

d. Cost Share Responsibility. Upon execution of this Amendment, each Party is responsible for its actual Cost Share regardless of the form and manner of payment described herein, such that the Party cannot terminate its Cost Share obligation for any reason. In the event of a withdrawal from the system in accordance with Section 20 of the Agreement or in the case of a default for failure to pay its Cost Share in accordance with this Amendment, each Party remains obligated to pay to County the Party's outstanding Cost Share as that obligation becomes due. Should any Party fail to pay its respective Cost Share when due, the County shall take action as is appropriate to obtain such payment. Nothing herein shall be construed as the County's exclusive remedy for the remediation of defaults by a Party or Parties,

and the County reserves the right to pursue any and all available rights and remedies at law or in equity.

e. County Trust Account. The County shall deposit all Cost Share contributions into a trust account that is managed solely for the purpose of the System Extension.

2. System Extension Administration. The Orange County Sheriff-Coroner Department/Communications & Technology Division shall administer all agreements for the System Extension, and regularly report such progress to the Governance Committee.

3. Participating Agencies. The Parties hereby update the list of Participating Agencies described on Exhibit D, attached hereto, which shall replace in its entirety Exhibit C of the Agreement. Participating Agencies will continue to contribute to overall backbone costs through the payment of a separate and established entry fee for every radio added to the system.

4. Capitalized Terms. Any capitalized terms not defined herein shall have the meanings set forth in the Agreement.

5. Counterparts. This Amendment may be executed in two or more counterparts, each of which shall be deemed an original, but all of which together shall constitute but one and the same instrument.

6. Full Force. Except as expressly set forth herein, the Agreement shall remain unmodified and in full force and effect.

IN WITNESS WHEREOF, the Parties have executed this Amendment as of the date first written above.

THE COUNTY OF ORANGE,
a political subdivision of the State of California

By: _____
Chairman of the Board of Supervisors

SIGNED AND CERTIFIED THAT A COPY
OF THIS DOCUMENT HAS BEEN DELIVERED
TO THE CHAIRMAN OF THE BOARD

By: _____
Clerk of the Board of Supervisors
County of Orange, California

APPROVED AS TO FORM:
COUNTY COUNSEL

By: _____

[CITY SIGNATURE BLOCKS TO BE INSERTED]

Dated: _____

IN WITNESS WHEREOF, the parties have executed this Amendment as of the date first written above.

CITY OF GARDEN GROVE

ATTEST:

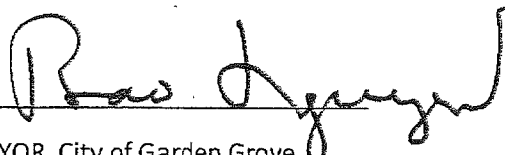
By: 
MAYOR, City of Garden Grove

City Clerk 3/17/2015

Approved As to Form:

City Attorney

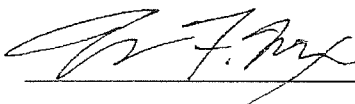

EXHIBIT A

PARTIES TO THE AMENDMENT

ENTITY	RESPONSIBLE ADMINISTRATOR	ADDRESS	PHONE #
Aliso Viejo	City Manager	12 Journey, Suite 100 Aliso Viejo, CA 92656-5335	949/425-2512
Anaheim	City Manager	200 S. Anaheim Blvd. Anaheim, CA 92805	714/765-5162
Brea	City Manager	1 Civic Center Circle Brea, CA 92821-5732	714/990-7770
Buena Park	City Manager	6650 Beach Blvd. Buena Park, CA 90620	714/562-3550
Costa Mesa	City Manager	77 Fair Drive Costa Mesa, CA 92626	714/754-5328
Cypress	City Manager	5275 Orange Avenue Cypress, CA 90630	714/229-6688
Dana Point	City Manager	33282 Golden Lantern, Suite 203 Dana Point, CA 92629	949/248-3513
Fountain Valley	City Manager	10200 Slater Avenue Fountain Valley, CA 92708	714/593-4410
Fullerton	City Manager	303 W. Commonwealth Ave Fullerton, CA 92832	714/738-6310
Garden Grove	City Manager	11222 Acacia Parkway Garden Grove, CA 92840	714/741-5100
Huntington Beach	City Administrator	2000 Main Street Huntington Beach, CA 92648	714/536-5575
Irvine	City Manager	1 Civic Center Plaza Irvine, CA 92623-9575	949/724-6246
La Habra	City Manager	201 E. La Habra Blvd. La Habra, CA 90633	562/905-9701

ENTITY	RESPONSIBLE ADMINISTRATOR	ADDRESS	PHONE #
La Palma	City Manager	7822 Walker Street La Palma, CA 90623	714/690-3333
Laguna Beach	City Manager	505 Forest Avenue Laguna Beach, CA 92651	949/497-0704
Laguna Hills	City Manager	24035 El Toro Road Laguna Hills, CA 92653	949/707-2610
Laguna Niguel	City Manager	27801 La Paz Road Laguna Niguel, CA 92677	949/362-4300
Laguna Woods	City Manager	24264 El Toro Road Laguna Woods, CA 92653	949/639-0525
Lake Forest	City Manager	25550 Commercentre Drive Lake Forest, CA 92630	949/461-3410
Los Alamitos	City Manager	3191 Katella Avenue Los Alamitos, CA 90720	562/431-3538 ext. 201
Metro Cities Fire Authority	Manager	201 S. Anaheim Blvd., Suite 302 Anaheim, CA 92805	714/765-4077
Mission Viejo	City Manager	200 Civic Center Mission Viejo, CA 92691	949/470-3051
Newport Beach	City Manager	3300 Newport Blvd. Newport Beach, CA 92663-3884	949/644-3000
Orange	City Manager	300 East Chapman Ave. Orange, CA 92866	714/744-2222
Orange County Fire Authority	Fire Chief	1 Fire Authority Road Irvine, CA 92602	714/573-6010
Orange, County of	CEO	333 W. Santa Ana Blvd. Santa Ana, CA 92701	714/834-6200

ENTITY	RESPONSIBLE ADMINISTRATOR	ADDRESS	PHONE #
Placentia	City Administrator	401 East Chapman Ave Placentia, CA 92870	714/993-8117
Rancho Santa Margarita	City Manager	22112 El Paseo Rancho Santa Margarita, CA 92688	949/635-1800 ext. 210
San Clemente	City Manager	100 Avenida Presidio San Clemente, CA 92672	949/361-8322
San Juan Capistrano	City Administrator	32400 Paseo Adelanto San Juan Capistrano, CA 92675	949/443-6317
Santa Ana	City Manager	20 Civic Center Plaza Santa Ana, CA 92701	714/647-5200
Seal Beach	City Manager	211 8th Street Seal Beach, CA 90740	562/431-2527 ext. 300
Stanton	City Manager	7800 Katella Avenue Stanton, CA 90680-3162	714/379-9222 ext. 240
Tustin	City Manager	300 Centennial Way Tustin, CA 92780	714/573-3010
Villa Park	City Manager	17855 Santiago Blvd. Villa Park, CA 92861	714/998-1500
West Cities Police Communications	West-Comm Administrator	911 Seal Beach Blvd. Seal Beach, CA 90740	562/594-7243
Westminster	City Manager	8200 Westminster Blvd. Westminster, CA 92683	714/898-3311 ext. 402
Yorba Linda	City Manager	4845 Casa Loma Avenue Yorba Linda, CA 92886	714/961-7110

EXHIBIT B

GENERAL DESCRIPTION OF SYSTEM EXTENSION AND PROJECT SCHEDULE

1.0 Overview

The System Extension plan will focus on extending the life of the existing CCCS radio system by systematically replacing end-of-life equipment in strategic phases culminating in an upgrade to P25 compliance with the goal of continuing to provide quality radio communications to the law, fire, lifeguard and public works agencies in Orange County.

2.0 Description of System Extension

- 2.1 *System Backbone* – Radio infrastructure equipment that is at or near the end of its expected life will be directly replaced with the current version of the same equipment that will maintain all existing features and functionalities and is able to work with the existing backhaul network. Specifically, this will involve the replacement of 565+ existing Quantar radio base stations and ancillary equipment at 25 radio sites with 800 MHz 3600 baud GTR8000 base stations and ancillary equipment. This will be accomplished in accordance with the following schedule:

System Backbone schedule:

Northwest Cell = 24 Quantars replaced in 2015
Southwest Cell = 40 Quantars replaced in 2015
Laguna Cell = 33 Quantars replaced in 2016
Moorhead IR Site = 8 Quantars replaced in 2016
North Cell = 105 Quantars replaced in 2016
South Cell = 135 Quantars replaced in 2017
Crystal Cove IR Site = 4 Quantars replaced in 2017
Countywide Cell = 210 Quantars replaced in 2017
Carbon Canyon IR Site = 3 Quantars replaced in 2017
Silverado IR Site = 3 Quantars replaced in 2017

- 2.2 *Law Enforcement Dispatch Consoles* – Police Dispatch Gold Elite consoles will be out-of-service by the vendor in 2018 and will need to be replaced prior to 2018 to maintain the existing console priority feature once the system is upgraded to P25. Console priority is a feature unique to law enforcement dispatch and allows dispatch to have the ability to transmit and receive audio simultaneously and is an officer safety necessity. Existing Gold Elite Console equipment will be replaced with its successor console, the MCC7500. Due to the complexity of the replacement at each law dispatch center, only 6 dispatch centers can be upgraded each year. A schedule has been developed to address the 20 law dispatch centers on the system, as shown below.

Console schedule:

FY14/15 - Loma Ridge, Irvine, Laguna Beach, Huntington Beach

FY15/16 - Anaheim, Brea, West Comm, Santa Ana, Tustin

FY16/17 - Orange, Fullerton, Costa Mesa, Garden Grove, Westminster

FY17/18 - Placentia, La Palma, Newport Beach, Fountain Valley,
Buena Park, La Habra

- 2.3 *System Field Equipment* – When the System Backbone is upgraded to the P25 standard in FY 2018/2019, all subscriber radio equipment will also need to be P25 capable. Subscriber radios that are capable of being upgraded will need to receive the software/firmware upgrade prior to the backbone upgrade. Older subscriber radio equipment that is not capable of being upgraded to the P25 standard will need to be replaced prior to the P25 upgrade. Each agency will be responsible for the purchase of either replacement radios, or the necessary subscriber upgrade package for upgradable radios.
- 2.4 *P25 Upgrade* – When all backbone sites and law dispatch consoles have completed their equipment replacement, the vendor will initiate the necessary equipment and software update to bring the system up to the 7.18 software platform for P25 compliance. This final phase of the System Extension plan is scheduled for FY 2018/2019.

EXHIBIT C

TOTAL ESTIMATED SYSTEM EXTENSION COST & ESTIMATED PARTY COST SHARE BY FISCAL YEAR

CITY/AGENCY	ESTIMATED COST								
	FY 15-16 Radio Counts			City/Agency Cost		Partnership Cost			TOTAL
	Upgrade (P25 Capable With Software Upgrade)	Replace (Upgrade To P25 Not Possible)	Total	Console Equipment	Radio Equipment	FY 15-16 North & Laguna Cells	FY 16-17 South & Countywide Cells	FY 17-18 Remaining Backbone	
1. ALISO VIEJO	11	21	32	\$ -	\$ 138,650	\$ 7,028	\$ 16,930	\$ 43,599	\$ 208,206
2. ANAHEIM	432	1,351	1,783	1,928,869	8,802,800	361,545	1,054,756	2,429,268	14,407,241
3. BREA	62	302	364	846,137	1,863,300	79,891	215,329	499,936	3,322,593
4. BUENA PARK	76	258	334	588,804	1,635,400	73,278	197,562	458,062	2,931,124
5. COSTA MESA	105	523	628	860,354	3,258,750	137,968	371,502	858,626	5,304,197
6. CYPRESS	24	170	194	0	1,047,600	42,604	114,763	264,317	1,466,285
7. DANA POINT	15	49	64	0	311,280	14,054	37,560	87,198	450,362
8. FOUNTAIN VALLEY	45	204	249	443,290	1,275,750	54,702	147,298	339,253	2,260,394
9. FULLERTON	125	513	638	501,417	3,231,750	140,141	377,418	869,250	5,109,876
10. GARDEN GROVE	115	475	590	368,240	2,962,250	129,806	349,529	803,952	4,633,972
11. HUNTINGTON BEACH	452	820	1,272	1,097,718	5,439,600	279,386	752,489	1,733,051	9,802,436
12. IRVINE	111	303	414	432,208	3,145,650	134,878	363,220	836,551	4,912,509
13. LA HABRA	73	180	253	573,584	1,223,950	57,809	155,581	358,327	2,369,252
14. LA PALMA	31	51	82	166,901	241,650	18,008	48,506	111,722	666,789
15. LAGUNA BEACH	85	247	332	526,652	1,578,750	72,883	196,399	452,337	2,828,021
16. LAGUNA HILLS	4	41	45	0	250,600	9,875	26,620	61,311	348,497
17. LAGUNA NIGUEL	9	55	64	0	348,350	14,091	37,660	87,198	479,469
18. LAGUNA WOODS	2	4	6	0	28,300	1,330	3,549	8,175	39,354
19. LAKE FOREST	21	67	88	0	426,150	19,325	50,058	119,897	617,429
20. LOS ALAMITOS	15	45	60	0	287,250	13,176	35,494	81,749	417,668
21. METRONET	37	10	47	1,966,250	102,580	10,321	27,803	64,036	2,170,960
22. MISSION VIEJO	30	80	110	0	574,500	28,368	70,986	163,495	835,349
23. NEWPORT BEACH	436	401	837	532,594	2,909,700	184,290	496,322	1,143,105	5,266,351
24. ORANGE	115	514	629	598,812	3,216,250	137,888	372,034	856,988	5,181,233
25. PLACENTIA	38	107	145	413,693	676,500	30,119	81,044	186,657	1,367,410
26. RANCHO SANTA MARG.	7	29	36	0	182,050	7,906	21,296	49,049	260,301
27. SAN CLEMENTE	12	97	109	0	566,800	29,931	64,480	148,508	802,719
28. SAN JUAN CAPISTRANO	6	23	29	0	204,900	8,525	23,071	53,136	266,632
29. SANTA ANA	218	818	1,036	591,620	5,159,850	227,713	613,451	1,412,872	8,005,506
30. SEAL BEACH	25	97	122	0	610,750	26,844	72,171	166,220	875,965
31. STANTON	10	63	73	0	389,500	18,051	43,184	99,460	548,195
32. TUSTIN	81	243	324	483,289	1,551,450	71,126	191,557	441,437	2,736,646
33. VILLA PARK	0	6	6	0	36,000	1,318	3,549	8,175	49,042
34. WEST-COMB	4	13	17	631,052	62,600	3,733	10,057	23,162	730,604
35. WESTMINSTER	73	274	347	549,621	1,727,950	76,137	205,273	472,774	3,031,755
36. YORBA LINDA	35	62	97	0	412,250	21,302	57,382	132,159	623,092
37. OCHA	850	863	1,713	3,217,500	6,270,500	367,622	1,072,505	2,470,142	13,428,269
38. OCTA	70	43	113	0	338,500	24,875	66,847	153,958	584,179
39. OC LIFE GUARD	7	47	54	436,900	290,050	11,865	31,944	73,573	846,533
40. IRVINE VILLY. CLLG. PD	15	0	15	0	18,400	3,527	9,465	21,768	53,162
41. SANTA ANA UNIF. SD. PD	51	2	53	0	70,850	11,639	31,353	72,210	165,852
42. SANDLERACK CLLG. PD	18	0	18	0	20,700	3,853	10,646	24,524	59,625
43. CEO	1	1	2	0	7,450	438	1,183	2,725	11,497
44. DA	0	225	225	0	1,350,000	49,411	133,102	306,554	1,839,067
45. HCA	184	98	282	0	799,600	61,804	166,821	384,214	1,412,439
46. JWA	36	194	230	536,250	1,208,850	51,175	137,634	317,453	2,251,563
47. OC ANIMAL CONTROL	10	110	120	358,000	671,500	28,386	70,986	163,495	1,262,369
48. OC DANA POINT HARBOR	0	13	13	0	78,000	2,622	7,690	17,712	106,225
49. OC PARKS	131	246	377	0	1,636,850	83,218	224,203	516,373	2,462,443
50. OCPW	10	469	479	0	2,825,500	105,276	283,358	652,819	3,866,749
51. OCWR	59	3	62	0	85,850	13,602	36,677	84,473	220,602
52. PROBATION	177	455	632	0	2,813,500	134,685	362,037	833,628	4,144,108
53. SHERIFF	857	1,823	2,680	4,428,829	12,517,500	610,825	1,843,955	3,786,390	22,967,439
54. SSA	19	0	19	0	21,850	4,173	11,340	25,687	63,149
TOTAL						\$ 4,162,452	\$ 11,211,905	\$ 25,822,727	

The costs stated herein are estimated costs expressed as not to exceed amounts subject to the final system design.

* It is recommended that the Partnership co-ordinate a bulk equipment purchase in FY 16-17.

\$41,197,084
PARTNERSHIP TOTAL

January 2015

EXHIBIT D

PARTICIPATING AGENCIES

AGENCY	RESPONSIBLE ADMINISTRATOR	ADDRESS	PHONE #
Irvine Valley College Police Department	Police Chief	5500 Irvine Center Drive, Irvine CA 92618	949/451-5201
Orange County Transportation Authority	Administrator	600 S. Main Street, Orange CA 92868	714/560-6282
Saddleback College Police Department	Police Chief	28000 Marguerite Parkway, Mission Viejo CA 92692	949/582-4390
Santa Ana Unified School District Police Department	Police Chief	1601 E. Chestnut Avenue, Santa Ana CA 92701	714/558-5536
US Ocean Safety (OC Lifeguards)	President	34127 Pacific Coast Highway, Dana Point CA 92629	949/276-5050

Zimbra**davidba@ci.garden-grove.ca.us**

Cyber Security

From : David Barlag <davidba@ci.garden-grove.ca.us>

Wed, Mar 18, 2015 01:29 PM

Subject : Cyber Security**To** : lancelarson@ocaic.org**Cc** : Anand Rao <anandr@ci.garden-grove.ca.us>

Mr. Larson,

I attended your presentation at the last OCEMO meeting in Buena Park.

You mentioned that there is a program to look at the security of our internal information systems?

I would be interested to see what is involved and how we proceed further.

I have CC the IT Division Manager Anand Rao on this email as well.

Look forward to hearing from you.

--

David R. Barlag
City Manager's Office
City of Garden Grove
(714) 741-5994

Zimbra

davidba@ci.garden-grove.ca.us

Language for Municipal Code Changes

From : David Barlag <davidba@ci.garden-grove.ca.us>

Wed, Mar 18, 2015 02:54 PM

Subject : Language for Municipal Code Changes**To :** omar sandoval <osandoval@wss-law.com>**Cc :** Tom Nixon <tomn@ci.garden-grove.ca.us>

Omar,

Can you prepare language for the addition of Public Contract Code 22160-22169

I assume it will modify this Chapter,

2.50.100 Formal Contract Procedure

--

David R. Barlag
City Manager's Office
City of Garden Grove
(714) 741-5994

Zimbra**davidba@ci.garden-grove.ca.us**

Hot Red s for GG

From : David Barlag <davidba@ci.garden-grove.ca.us>

Thu, Mar 19, 2015 02:05 PM

Subject : Hot Red s for GG**To :** Kim Caplan <kim.caplan@motorolasolutions.com>

Hi Kim,

So is the quote 021315GGAPXHRR,

A good number for the GG purchase?

How can we put this in the pipe for kick off in July?

It was approved for purchase at our last Council Meeting 3/10/15 in the 15/16 budget year.

Are these radio's currently produced?

--

David R. Barlag
City Manager's Office
City of Garden Grove
(714) 741-5994

Zimbra

davidba@ci.garden-grove.ca.us

Fwd: Hot Red s for GG

From : David Barlag <davidba@ci.garden-grove.ca.us>

Thu, Mar 19, 2015 03:02 PM

Subject : Fwd: Hot Red s for GG

📎 2 attachments

To : Ben Stauffer <stauffer@ci.garden-grove.ca.us>, Rebecca Meeks <rebeccam@ci.garden-grove.ca.us>, Courtney Allison <courta@ci.garden-grove.ca.us>

Hello All,
So the Hot Reds went through last Council meeting 3/10/15.
See the attached email string as far timing.
I am not sure PD's plan for the installation of these radios.
You should probably figure that portion into the supplemental as well.
Is the install through OCC or an outside contractor?
Just don't want you to get these radios and have no means to install.

Give me a call if I can help,
David Barlag
714 741-5994

From: "Kim Caplan" <Kim.Caplan@motorolasolutions.com>
To: "David Barlag" <davidba@ci.garden-grove.ca.us>
Sent: Thursday, March 19, 2015 2:30:59 PM
Subject: RE: Hot Red s for GG

Hi Dave,

The attached quote has been updated. The pricing didn't change, we just had change how the parts were ordered on the motorcycle configuration.

If you need the radios in the beginning of July what you could do is place an order in May or June with instructions not to ship until after July 1st. We don't invoice until the radios ship and it usually takes 4-8 weeks to build the radios depending on the factory workload.

Yes, these radios are produced and have been shipping.

Kim Caplan
Senior Account Manager
Motorola Solutions, Inc.
O: 760-630-5199
M: 858-442-3979



From: David Barlag [mailto:davidba@ci.garden-grove.ca.us]
Sent: Thursday, March 19, 2015 2:05 PM
To: Kim Caplan
Subject: Hot Red s for GG

Hi Kim,
So is the quote 021315GGAPXHRR,
A good number for the GG purchase?
How can we put this in the pipe for kick off in July?
It was approved for purchase at our last Council Meeting 3/10/15 in the 15/16 budget
year.
Are these radio's currently produced?

--

David R. Barlag
City Manager's Office
City of Garden Grove
(714) 741-5994

NOTE: This message was trained as non-spam. If this is wrong, please correct the training as soon as possible.

[Spam](#)

[Not spam](#)

[Forget previous vote](#)

--

David R. Barlag
City Manager's Office
City of Garden Grove
(714) 741-5994



MOTOROLA SOLUTIONS image001.png
6 KB



GARDEN GROVE HRR QUOTE 3_19_15 Dave B.pdf

37 KB



Motorola Solutions
6450 Sequence Drive
San Diego, Ca 92121

Attention: Kim Caplan
Phone: 858-442-3979
Kim.Caplan@Motorola.com

Quote:031915HRRGG

PREPARED FOR: Dave Barlag
COMPANY : Garden Grove

Equipment Details and Pricing

<u>Qty.</u>	<u>Model</u>	<u>Description</u>	<u>List</u>	<u>OC Price Book</u>	<u>Promo</u>	<u>Extended</u>
MOBILE HOT RED RECEIVER RADIO						
HOT RED RECEIVER GREEN RADIO MOBILE						
83	M25URS9PW1 N	APX6500 700/800 MHZ MID POWER MOBILE 10-35 WATT	\$12,533.00	\$8,397.11	\$6,266.50	\$520,119.50
83	G51	ADD: SMARTZONE OPERATION				
83	G806	ADD: ASTRO DIGITAL CAI OPERATION				
83	GA00805	ADD: APX 07 CONTROL HEAD				
83	G444	ADD: CONTROL HEAD SOFTWARE				
83	G851	ADD: AES/DES-XL/DES-OFB ENCR YPTION				
83	W969	ADD:MULTI-KEY				
83	G361	ADD:P25 TRUNKING				
83	G67	ADD: REMOTE MOUNT MID POWER				
83	G335	ADD: ANT 1/4 WAVE 762-870 MHZ				
83	W22	ADD: PALM MICROPHONE				
83	B18	ADD: AUXILIARY SPKR 7.5 WATT				
83	W599	ADD: 8 MODE DIRECT ENTRY				
83	GA001115	ADD: DUAL RADIO STACKABLE MID POWER TRUNNION				
83	GA01113AA	ENH: DUAL RADIO OPERATION (PRIMARY RADIO)				
83	GA05100AA	DEL: NO SFS-STD WARRANTY APPLIES				
HOT RED RECEIVER RED RADIO MOBILE						
83	M25URS9PW1 N	APX6500 700/800 MHZ MID POWER MOBILE 10-35 WATT				
83	G51	ADD: SMARTZONE OPERATION				
83	G806	ADD: ASTRO DIGITAL CAI OPERATION				
83	G361	ADD:P25 TRUNKING				
83	G88	ADD: NO CONTROL HEAD NEEDED				
83	G444	ADD: CONTROL HEAD SOFTWARE				
83	G67	ADD: REMOTE MOUNT MID POWER				
83	G335	ADD: ANT 1/4 WAVE 762-870 MHZ				
83	G90	ADD: NO MICROPHONE NEEDED				
83	B18	ADD: AUXILIARY SPKR 7.5 WATT				
83	GA01117AA	ENH: DUAL RADIO OPERATION (SECONDARY RADIO)				
83	GA05100AA	DEL: NO SFS-STD WARRANTY APPLIES				
MOTORCYCLE HOT RED RECEIVER RADIO						
HOT RED RECEIVER GREEN RADIO MOTORCYCLE						
9	M30URS9PW1 N	APX7500 700/800 MHZ MID POWER MOBILE 10-35 WATT	\$13,769.00	\$9,225.23	\$6,884.50	\$61,960.50
9	G51	ADD: SMARTZONE OPERATION				
9	G806	ADD: ASTRO DIGITAL CAI OPERATION				
9	GA00805	ADD: APX 07 CONTROL HEAD				
9	G361	ADD:P25 TRUNKING				
9	G851	ADD: AES/DES-XL/DES-OFB ENCR YPTION				
9	W969	ADD:MULTI-KEY				
9	G444	ADD: CONTROL HEAD SOFTWARE				
9	G67	ADD: REMOTE MOUNT MID POWER				
9	G89	ADD: NO ANTENNA NEEDED				
9	B18	ADD: AUXILIARY SPKR 7.5 WATT				
9	GA001115	ADD: DUAL RADIO STACKABLE MID POWER TRUNNION				
9	G138	ADD: APX MOTORCYCLE CH SFWR				
9	W620	ADD: NO MTRCYCLE ENCL NEEDED APEX				
9	GA01116	ADD: DUAL RADIO AUDIO COMBINER				
9	GA01113AA	ENH: DUAL RADIO OPERATION (PRIMARY RADIO)				
9	G90	ADD: NO MICROPHONE NEEDED				
9	HMN1090	ADD: PALM MICROPHONE (W22 ADD PALM REGULAR/NOT MOTORCYCLE)				
9	GA05100AA	DEL: NO SFS-STD WARRANTY APPLIES				
HOT RED RECEIVER RED RADIO MOTORCYCLE						
9	M30URS9PW1 N	APX7500 700/800 MHZ MID POWER MOBILE 10-35 WATT				
9	G51	ADD: SMARTZONE OPERATION				
9	G806	ADD: ASTRO DIGITAL CAI OPERATION				
9	G361	ADD:P25 TRUNKING				
9	G88	ADD: NO CONTROL HEAD NEEDED				
9	G444	ADD: CONTROL HEAD SOFTWARE				
9	G67	ADD: REMOTE MOUNT MID POWER				
9	G89	ADD: NO ANTENNA NEEDED				
9	G90	ADD: NO MICROPHONE NEEDED				
9	G138	ADD: APX MOTORCYCLE CH SFWR				
9	W620	ADD: NO MTRCYCLE ENCL NEEDED APEX				

9	B18	ADD: AUXILIARY SPKR 7.5 WATT	
9	GA01117AA	ENH: DUAL RADIO OPERATION (SECONDARY RADIO)	
9	GA05100AA	DEL: NO SFS-STD WARRANTY APPLIES	
HOT RED RECEIVER MOTORCYCLE PARTS			
9	H1835A	8 MODE DIRECT ENTRY	(Included in radio package price)
9	HKN6169B	CABLE, REMOTE MOUNT, 5M	(Included in radio package price)
9	HMN1090	ADD: PALM MICROPHONE	(Included in radio package price)

PROMOTIONAL PRICE ONLY VALID IF RADIOS PURCHASED BY NOVEMBER 2015 AND SHIPPED BY DECEMBER 31, 2015

Pricing per Orange County Price Book Agreement # MA-060-10012594
Pricing Includes Orange County 2015 Hot Red Receiver Promotional Discount

SUBTOTAL	\$582,080.00
TAXES	\$46,566.40
SHIPPING	\$5,820.80

\$634,467.20

QUOTE TERMS AND CONDITIONS :

- 1) Quotes are exclusive of all installation and programming charges(unless expressly stated) and all applicable taxes.
- 2) Purchaser will be responsible for shipping costs, which will be added to the invoice.
- 3) Prices quoted are valid for thirty(30) days from the date of this quote.
- 4) Unless otherwise stated, payment will be due within thirty days after invoice.
- 5) The information provided in this quote is provided for budgetary purposes only, and does not constitute an offer to sell or license any Motorola product.

Zimbra

davidba@ci.garden-grove.ca.us

Fwd: Cyber Security

From : David Barlag <davidba@ci.garden-grove.ca.us>
Subject : Fwd: Cyber Security
To : Anand Rao <anandr@ci.garden-grove.ca.us>

From: "Cecily Garcia" <Cecily.Garcia@ociac.org>
To: davidba@ci.garden-grove.ca.us
Cc: "OCIAC Cyber" <OCIACCyber@ociac.org>, "Lance Larson" <Lance.Larson@ociac.org>
Sent: Thursday, March 19, 2015 3:48:12 PM
Subject: RE: Cyber Security

David,

Nice to meet you! I have arranged a conference call tomorrow with the Department of Homeland Security and vulnerability reports for state and local governments. I have attached that invite, which includes clarification throughout the county to participate.

I also recommend you take a look at the Cyber Resiliency Review (CRR) that has been developed by USCIB. It is a one-day, no-cost evaluation done by the Department of Homeland Security. The checklist is very straightforward and can be found here:

[https://www.us-cert.gov/ccubedvp/self-service-crr#Downloadable Resources](https://www.us-cert.gov/ccubedvp/self-service-crr#Downloadable%20Resources)

This is a great way to get started with assessing your overall cyber security posture. The CRR covers everything from summarizing the assessment along with suggestions for improvement. I have found that reports like these are often overlooked by executive management, as lack of funding often leads to outdated (and unsecure) systems. I have attached the report for your review.

Please let me know if you need anything else!

Cecily M. Garcia
Cyber Intelligence Analyst
Orange County Intelligence Assessment Center (OCIAC)
California State Threat Assessment System (STAS)
Desk: (714) 289-3974
Cell: (714) 404-5279
Unclass: cecily.garcia@ociac.org
Secret: cecily.garcia.sle@dhs.gov

̄
S E M P E R F I

WARNING: This information should be considered Unclassified // For Official Use Only // Law Enforcement
contains information that may be exempt from public release under the Freedom of Information Act (5 U

distributed, and disposed of in accordance with US Department of Homeland Security policy relating to f or other personnel who do not have a valid "need-to-know" and shall not be distributed beyond the origir Receipt acknowledges a commitment to comply with all applicable laws protecting privacy, civil rights, ar destruction, sharing and disclosure of information. If you have any questions of need additional informat

From: Larson, Lance
Sent: Wednesday, March 18, 2015 8:37 PM
To: davidba@ci.garden-grove.ca.us
Cc: OCIAC Cyber
Subject: RE: Cyber Security

David,

Thank you for the email and the interest. Let me introduce you to my partner Cecily who is organizing this prograr to you shortly

* sent from mobile device

Highest Regards,

Lance Larson, Ph.D., CISSP
Reserve Officer
Laguna Beach Police Department
Cyber Program Advisor & TLO
Orange County Intelligence Assessment Center (OCIAC)
Voicemail: (949) 497-0701 x 273
Email: lance.larson@ociac.org (Unclassified), lance.larson.sle@dhs.gov (Secret)
OCIAC 24/7 Tips/Leads: 714-289-3949 / <http://www.ociac.org>

[<http://new.calstas.org/html/OCIAC%20logo.gif>]

WARNING: This information should be considered Unclassified // For Official Use Only // Law Enforcement Sensiti that may be exempt from public release under the Freedom of Information Act (5 USC 552). It is to be controlled, accordance with US Department of Homeland Security policy relating to FOUO information and is not to be releas "need-to-know" and shall not be distributed beyond the original addressees without prior authorization of the ori applicable laws protecting privacy, civil rights, and civil liberties in the collection, use, analysis, retention, destructi of need additional information, please contact OCIAC at (714) 289-3949.

-----Original Message-----

From: David Barlag [davidba@ci.garden-grove.ca.us]
Received: Wednesday, 18 Mar 2015, 13:53
To: Larson, Lance [Lance.Larson@ociac.org]
Subject: Fwd: Cyber Security

From: "David Barlag" <davidba@ci.garden-grove.ca.us>

To: lancelarson@ocaic.org
Cc: "Anand Rao" <anandr@ci.garden-grove.ca.us>
Sent: Wednesday, March 18, 2015 1:29:09 PM
Subject: Cyber Security

Mr. Larson,
I attended your presentation at the last OCEMO meeting in Buena Park.
You mentioned that there is a program to look at the security of our internal information system. I would be interested to see what is involved and how we proceed further.
I have CC the IT Division Manager Anand Rao on this email as well.
Look forward to hearing from you.

--

David R. Barlag
City Manager's Office
City of Garden Grove
(714) 741-5994

--

David R. Barlag
City Manager's Office
City of Garden Grove
(714) 741-5994

[Spam](#)
[Not spam](#)
[Forget previous vote](#)

--

David R. Barlag
City Manager's Office
City of Garden Grove
(714) 741-5994

From : Emily McLoughlin (CTR) <emily.j.mcloughlin@associates.hq.dhs.gov>
Subject : Stakeholder Call: Orange County Intel Assessment Center (OCIAC) - Cecily Garcia
To : Emily McLoughlin (CTR) <emily.j.mcloughlin@associates.hq.dhs.gov>, Robert Karas <robert.karas@ociac.org>, David Link <David.Link@HQ.DHS.GOV>, Cecily Garcia <Cecily.Garcia@ociac.org>, OCLEITA Member List <member-list@ocleita.org>, Philip James Davis <Philip.Davis@ociac.org>, OCIAC Cyber & Information Security <cyber@ociac.org>, Keith Tresh [HOA] <keith.tresh@hoa.ocgov.com>, FREDERICK D THOMPSON <FThompson@occsd.org>, MAURY L RAUCH <mlrauch@ocsd.org>, Todd Keith <TKeith@anaheimcity.org>

III (afjohnson@anaheim.net) <afjohnson@anaheim.net>, Shelley McKerren (SMcKerren@SMcKerren@anaheim.net), OCIAC Supervisors <OCIAC Supervisors>, Heather Houston Jim Lentz (jlentz@santa-ana.org) <jlentz@santa-ana.org>

Call start time: 1:00 PM EST/10:00 AM PST

Cecily,

Feel free to send this along to other participants. Please see the attached documents. The first is our capability brief that we will go over d letter, these documents must be completed in order to receive services. Please look over these and let us know if you have any questions. the type of reports you will get back from our office.

Thanks,

EmilyJane

EmilyJane McLoughlin

National Cybersecurity Assessment and Technical Services
National Cybersecurity and Communications Integration Center
U.S. Department of Homeland Security
Phone: (202)669-7033



Cyber Hygiene Sample.pdf

570 KB [View](#) [Download](#)



Agency Acceptance Letter - CH Service - SLTT_PS.PDF

927 KB [View](#) [Download](#)



RVA Report Fed Template 2014 - EJM.DOCX

474 KB [View](#) [Download](#)



DHS_NCCIC_NCATS - Capability Brief.pptx

2 MB [View](#) [Download](#)



RVA ROE SLTT.PDF

1 MB [View](#) [Download](#)



[Download all attachments](#)



CRR Factsheet.pdf

118 KB

Zimbra

davidba@ci.garden-grove.ca.us

Accept: FW: Stakeholder Call: Orange County Intel Assessment Center (OCIAC) - Cecily Garcia

From : David Barlag <davidba@ci.garden-grove.ca.us>

Thu, Mar 19, 2015 04:51 PM

Subject : Accept: FW: Stakeholder Call: Orange County Intel Assessment Center (OCIAC) - Cecily Garcia

To : emily j mcloughlin <emily.j.mcloughlin@associates.hq.dhs.gov>

Subject: FW: Stakeholder Call: Orange County Intel Assessment Center (OCIAC) - Cecily Garcia

Organizer: emily.j.mcloughlin@associates.hq.dhs.gov

Location: Conference Bridge: 202-243-6160 or 1-877-711-5292, Pin: 547178

Time: Friday, March 20, 2015, 1:00:00 PM - 1:30:00 PM GMT -05:00 US/Canada Eastern

Invitees: davidba@ci.garden-grove.ca.us

~~*~*~*~*~*~*~*~*

Yes, I will attend.

Zimbra

davidba@ci.garden-grove.ca.us

Fwd: Request for Rotation in OCEMS Designated Non-OCEMS Administered OA Ambulance Zone - Garden Grove

From : David Barlag <davidba@ci.garden-grove.ca.us> Fri, Mar 20, 2015 06:36 PM
Subject : Fwd: Request for Rotation in OCEMS Designated Non-OCEMS Administered OA Ambulance Zone - Garden Grove 📎 2 attachments
To : Tom Nixon <tomn@ci.garden-grove.ca.us>, Omar Sandoval <omars@ci.garden-grove.ca.us>

David R. Barlag

Begin forwarded message:

From: "McConnell, Tammi" <TMcConnell@ochca.com>
Date: March 20, 2015 at 6:22:05 PM PDT
To: Barlag David <davidba@ci.garden-grove.ca.us>
Subject: Fwd: Request for Rotation in OCEMS Designated Non-OCEMS Administered OA Ambulance Zone - Garden Grove

Tammi McConnell RN, MSN
Orange County EMS
Sent from my iPhone

Begin forwarded message:

From: "McConnell, Tammi" <TMcConnell@ochca.com>
Date: March 20, 2015 at 3:57:03 PM PDT
To: "Warren Hartley (warrenh@garden-grove.org)" <warrenh@garden-grove.org>
Cc: "allenr@ci.garden-grove.ca.us" <allenr@ci.garden-grove.ca.us>, "Stratton, Samuel" <SStratton@ochca.com>, "Veale, Holly" <HVeale@ochca.com>, "Refowitz, Mark" <MRefowitz@ochca.com>
Subject: FW: Request for Rotation in OCEMS Designated Non-OCEMS Administered OA Ambulance Zone - Garden Grove

Good afternoon Chief,

Per my voicemail left today, our office has received the 3/19/15 AmeriCare letter

requesting rotation and would like to share a copy of the 3/18/15 letter from Dr. Stratton regarding this matter. If you have further questions, please do not hesitate to contact me at 714-834-2791 or Dr. Stratton when he returns on Monday.

Regards,

[Spam](#)

[Not spam](#)

[Forget previous vote](#)

Tammi McConnell MSN, RN, MICN, PHN

EMS Administrator

Orange County Emergency Medical Services

405 W. Fifth Street, Suite 301A Santa Ana, CA 92701

Direct: 714.834.2791

[Website](#) | [Facebook](#) | [Twitter](#)

CAUTION: Unless containing HIPAA sensitive information, general emails to this address are often subject to public records requests.

If you have received this electronic mail message and are not listed in the address line, please notify the sender at tmccconnell@ochca.com. The information and attachments contained in this message are intended for the identified recipient(s) and no others. Forwarding or relaying in any way confidential patient or institutional information without prior authorization may constitute violation of state and federal statutes that will result in criminal liability for the forwarding party.

P Please consider the environment before printing this e-mail

From: Jim Karras [<mailto:jkarras@americare.org>]

Sent: Thursday, March 19, 2015 7:07 PM

To: allanr@ci.garden-grove.ca.us

Cc: McConnell, Tammi; Refowitz, Mark;

Howard.Backer@EMSAuthority.ca.gov; Michael Summers

Subject: Request for Rotation in OCEMS Designated Non-OCEMS Administered OA Ambulance Zone - Garden Grove

Attached, please find a letter from Mr. Michael Summers, President/CEO of AmeriCare Ambulance.

Thank you.

Sincerely,

Jim Karras

Vice President and Chief Operating Officer

*AmeriCare Ambulance Service***Corporate Offices**

1059 East Bedmar Street, Carson, CA 90746-3601

Dispatch: (888) 923-9723 | **Office:** (310) 835-9390 x167 | **Fax:** (310) 835-3926**E-mail:** jkarras@americare.org | **Web:** www.americare.org*Proudly serving Los Angeles, Orange, Riverside and San Diego counties.*

Please consider the environment prior to printing or viewing sensitive or confidential material

WARNING: THIS E-MAIL IS COVERED BY THE ELECTRONIC COMMUNICATIONS PRIVACY ACT, 18 U.S.C. 2510-2521 AND IS LEGALLY PRIVILEGED. IT MAY CONTAIN CONFIDENTIAL HEALTH INFORMATION THAT IS LEGALLY PROTECTED BY STATE AND FEDERAL LAW, INCLUDING, BUT NOT LIMITED TO THE HEALTH INSURANCE PORTABILITY AND ACCOUNTABILITY ACT OF 1996 AND RELATED REGULATIONS OR OTHER INFORMATION FROM AMERICARE AMBULANCE OR JIM KARRAS, WHICH MAY BE PRIVILEGED, CONFIDENTIAL AND EXEMPT FROM DISCLOSURE UNDER APPLICABLE LAW. DISSEMINATION OR COPYING OF THIS BY ANYONE OTHER THAN THE ADDRESSEE OR THE ADDRESSEE'S AGENT IS STRICTLY PROHIBITED. IF THIS ELECTRONIC TRANSMISSION IS RECEIVED IN ERROR, PLEASE NOTIFY JIM KARRAS/AMERICARE AMBULANCE IMMEDIATELY AT (310) 835-9390 X167 AND DESTROY THE ORIGINAL TRANSMISSION AND ITS ATTACHMENTS WITHOUT READING THEM OR SAVING THEM TO DISK. THANK YOU.

**MS Letter to Garden Grove re Non-OCEMS EOA Assignment Request 3-19-15.pdf**

67 KB

**#2261 Reply to AmeriCare 2_25-15 Ltr.pdf**224 KB



1059 East Bedmar Street
Carson, California 90746
Office: (310) 835-9390
Fax: (310) 835-3926
Internet: americare.org

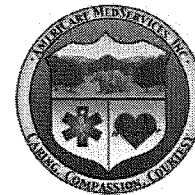

March 19, 2015

Sent via e-mail to: allanr@ci.garden-grove.ca.us

Allan L. Roeder, Interim City Manager
City of Garden Grove
11222 Acacia Parkway
Garden Grove, CA 92840

Re: Request for Rotation in OCEMS Designated Non-OCEMS Administered OA Ambulance Zone OA 8 – Garden Grove

Dear Mr. Roeder:

AmeriCare MedServices, Inc. (“AmeriCare”) a privately family-owned and operated Orange County-based California Corporation which is qualified and licensed to provide emergency ambulance service throughout Orange County and that has been serving Orange County since its corporate organizational formation in 1996.

We are writing to you today at the direction of Dr. Samuel Stratton, Medical Director, Orange County EMS (“OCEMS”) a division of the Orange County Health Care Agency. As you may know, the Orange County Board of Supervisors has designated OCEMS to serve as its designated Local Emergency Medical Services Agency (“LEMSA”) pursuant to California Health and Safety Code section 1797.200. In its 2014 EMS Plan, which has been submitted to and approved by the California EMS Authority pursuant to California Health and Safety Code sections 1797.250 and 1797.105, OCEMS has determined that its designated Ambulance Response Zone OA 8 – Garden Grove is a non-exclusive operating zone pursuant to California Health and Safety Code section 1797.224.

Pursuant to California Health and Safety Code section 1797.94, on February 25, 2015 we submitted a written request to OCEMS wherein we sought to be placed on rotation within OCEMS designated non-exclusive Ambulance Response Zone OA 8 – Garden Grove. On March 18, 2015 we received a written reply wherein Dr. Stratton directed us to contact the City Manager for the incorporated city within the zone. Therefore, we are requesting that the City arrange for AmeriCare to be placed into rotation for all 9-1-1 prehospital emergency medical services requests for emergency ambulance service within Zone OA 8 – Garden Grove in a manner that results in AmeriCare receiving an equal proportionate share of all such 9-1-1 prehospital emergency service requests within the zone.

We are making this request as we have reason to believe that as a non-exclusive Ambulance Response Zone, whichever entity (the County or the City) has the responsibility and authority related to the oversight, regulation and administration of prehospital emergency medical services and/or emergency ambulance operations within Ambulance Response Zone OA 8 – Garden Grove, also bears the liability of anti-trust claims as restrictions of trade within this Zone would not be provided with state action immunity under federal antitrust laws for such actions taken which run afoul of such federal antitrust laws.

If on the other hand, the City maintains the position that it does not has the responsibility and authority related to the oversight, regulation and administration of prehospital emergency medical services and/or emergency ambulance operations within Ambulance Response Zone OA 8 – Garden Grove, upon such timely written confirmation of such a position in response to this written communication, AmeriCare will redirect its communications to the County in an effort to seek relief for our desire to enjoy the fruits of a free and competitive market for the industry in which we are engaged in.

We note that the City entered into an Ambulance Contract City Agreement with the County on 09/24/1986. Based on this, we believe the matter of administration, and regulation of private ambulance services providing emergency ambulance service within the City has long been delegated by the City to the County pursuant to the above referenced agreement. Please let us know the City believes otherwise.

Caring . . . Compassion . . . Courtesy – AmeriCare Ambulance Service – Dedicated to its employees

Allan L. Roeder, Interim City Manager, City of Garden Grove
Subject: OCEMS Designated Non-OCEMS Administered Ambulance Response Zone OA 8 – Garden Grove
March 19, 2015
Page 2 of 2

We thank you in advance for your careful consideration of the facts and requests made herein.

Sincerely,

A handwritten signature in black ink that reads "Mike Summers". The signature is written in a cursive, slightly slanted style.

Mike Summers
President/CEO
AmeriCare Ambulance Service

Cc: Samuel Stratton, MD, Medical Director, OCEMS, via e-mail at: [sstratton@ochca.com](mailto:ss Stratton@ochca.com)
Tammi McConnell, EMS Administrator, OCEMS, via e-mail at: TMcConnell@ochca.com
Mark Refowitz, Director, OCHCA, via e-mail at: mrefowitz@ochca.com
Howard Backer, MD, via e-mail at: Howard.Backer@EMSAuthority.ca.gov



**COUNTY OF ORANGE
HEALTH CARE AGENCY**

**HEALTH DISASTER MANAGEMENT
EMERGENCY MEDICAL SERVICES**

*Excellence
Integrity
Service*

MARK REFOWITZ
DIRECTOR

RICHARD SANCHEZ
Assistant Director

HOLLY A. VEALE
ACTING DEPUTY AGENCY DIRECTOR
MEDICAL SERVICES

LYDIA MIKHAIL, MBA
DIVISION MANAGER
HEALTH DISASTER MANAGEMENT

TAMMI McCONNELL RN, MSN
EMS ADMINISTRATOR

405 W FIFTH STREET, SUITE 301A
SANTA ANA, CALIFORNIA 92701

TELEPHONE: 714-834-3500
FAX: 714-834-3125

March 18, 2015

Mike Summers, President/CEO
1059 East Bedmar Street
Carson, California 90746

Dear Mr. Summers:

This letter is in reply to your letter sent via email on February 25, 2015.

The February 25 letter was in reply to a letter I had sent that same day in which it was understood from previous electronic communications that without financial relief from the Orange County Fire Authority (OCFA) or the County of Orange, AmeriCare would not be providing services after March 2, 2015, for the Villa Park Exclusive Operating Area (EOA) # 24. With this understanding in mind, it was the responsibility of the Orange County Emergency Medical Services Agency to arrange for 9-1-1 emergency ambulance coverage for the operating area.

While a number of other issues were raised in the February 25 AmeriCare letter, please be mindful that there was a need to assure that EOA # 24 had 9-1-1 emergency ambulance coverage after March 2 and there was no intent to interfere with AmeriCare-OCFA negotiations or to exert legal authorities.

With respect to the AmeriCare February 25 letter request to provide service in the twelve cities listed that administer their own 9-1-1 emergency ambulance contracts, please contact the City Manager of those cities for further information. At present, each of the cities asserts that they retain statutory administrative rights for prehospital emergency medical services.

The Orange County EMS Agency very much appreciates the dedication and support of AmeriCare with continuing services to the Orange County community. Please feel free to contact me for questions or comments you may have.

With best regards,

Sam J. Stratton, MD, MPH
Orange County Emergency Medical Services Agency
Orange County Health Care Agency

SJS/#2261

Zimbra

davidba@ci.garden-grove.ca.us

Accept: Fire Station 6 and 7 Developer Impact Fees

From : David Barlag <davidba@ci.garden-grove.ca.us>

Mon, Mar 23, 2015 10:39 AM

Subject : Accept: Fire Station 6 and 7 Developer Impact Fees

To : ellisc@ci.garden-grove.ca.us

Subject: Fire Station 6 and 7 Developer Impact Fees

Organizer: ellisc@ci.garden-grove.ca.us

Location: Dave's Office

Time: Monday, March 23, 2015, 1:30:00 PM - 2:00:00 PM GMT -08:00 US/Canada Pacific

Invitees: davidba@ci.garden-grove.ca.us; harryw@ci.garden-grove.ca.us

~~*~*~*~*~*~*~*~*

Yes, I will attend.

Zimbra

davidba@ci.garden-grove.ca.us

Fwd: Request for Rotation Letters to Cities

From : David Barlag <davidba@ci.garden-grove.ca.us> Mon, Mar 23, 2015 02:19 PM
Subject : Fwd: Request for Rotation Letters to Cities 📎 13 attachments
To : Allan Roeder <allanr@ci.garden-grove.ca.us>, Tom Nixon <tomn@ci.garden-grove.ca.us>, omar sandoval <osandoval@wss-law.com>

From: "Tony Coppolino" <Tony.Coppolino@fountainvalley.org>
To: "Bill Kolberg" <william.kolberg@disney.com>, "Dan Stefano" <dan.stefano@costamesaca.gov>, "Dave Barlag" <davidba@ci.garden-grove.ca.us>, "Jeff LaTendresse" <jlatendress@lagunabeachcity.net>, "Keith Richter" <keithrichter@ocfa.org>, "Pat Dibb" <pdibb@cityoforange.org>, "Pat McIntosh (patrick.mcintosh@surfcity-hb.org)" <patrick.mcintosh@surfcity-hb.org>, "Randy Bruegman" <rbruegman@anaheim.net>, "Scott Poster" <sposter@nbfd.net>, "Wolf Knobe" <firechief@fullertonfire.org>
Sent: Monday, March 23, 2015 2:07:31 PM
Subject: FW: Request for Rotation Letters to Cities

If you are interested, these are all the cities that received the letter. Dr. Stratton received this late Thursday (he wanted it noted after he left FC's meeting).

Tony Coppolino
 Fire Chief
 Fountain Valley Fire Department
 714-745-6371 Cell
 714-593-4587 Office

Fountain Valley Fire Department

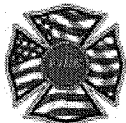

*Ethics
 Excellence
 Teamwork
 Dedication*

*50 Years of Service
 1964 - 2014*

From: Stratton, Samuel [mailto:SStratton@ochca.com]
Sent: Monday, March 23, 2015 10:39 AM
To: Tony Coppolino
Subject: FW: Request for Rotation Letters to Cities

Hi Tony,
 The attached letters give the list of cities we discussed.
 Sam

From: Jim Karras [<mailto:jkarras@americare.org>]
Sent: Thursday, March 19, 2015 8:43 PM
To: Stratton, Samuel
Cc: McConnell, Tammi; Michael Summers
Subject: Request for Rotation Letters to Cities

Hi Dr. Stratton,

I sent out the attached letters to the 12 cities pursuant to your 3/18/15 letter. Our intent was to copy you on each of the letters. But I inadvertently omitted you from the copy list. I apologize for that. So we are e-mailing them to you tonight so you remain in the loop.

Regards,

Jim Karras

Vice President and Chief Operating Officer

AmeriCare Ambulance Service

Corporate Offices

1059 East Bedmar Street, Carson, CA 90746-3601

Dispatch: (888) 923-9723 | **Office:** (310) 835-9390 x167 | **Fax:** (310) 835-3926

E-mail: jkarras@americare.org | **Web:** www.americare.org

Proudly serving Los Angeles, Orange, Riverside and San Diego counties.

Please consider the environment prior to printing or viewing sensitive or confidential material
WARNING: THIS E-MAIL IS COVERED BY THE ELECTRONIC COMMUNICATIONS PRIVACY ACT, 18 U.S.C. 2510-2521 AND IS LEGALLY PRIVILEGED. IT MAY CONTAIN CONFIDENTIAL HEALTH INFORMATION THAT IS LEGALLY PROTECTED BY STATE AND FEDERAL LAW, INCLUDING, BUT NOT LIMITED TO THE HEALTH INSURANCE PORTABILITY AND ACCOUNTABILITY ACT OF 1996 AND RELATED REGULATIONS OR OTHER INFORMATION FROM AMERICARE AMBULANCE OR JIM KARRAS, WHICH MAY BE PRIVILEGED, CONFIDENTIAL AND EXEMPT FROM DISCLOSURE UNDER APPLICABLE LAW. DISSEMINATION OR COPYING OF THIS BY ANYONE OTHER THAN THE ADDRESSEE OR THE ADDRESSEE'S AGENT IS STRICTLY PROHIBITED. IF THIS ELECTRONIC TRANSMISSION IS RECEIVED IN ERROR, PLEASE NOTIFY JIM KARRAS/AMERICARE AMBULANCE IMMEDIATELY AT (310) 835-9390 X167 AND DESTROY THE ORIGINAL TRANSMISSION AND ITS ATTACHMENTS WITHOUT READING THEM OR SAVING THEM TO DISK. THANK YOU.

NOTE: This message was trained as non-spam. If this is wrong, please correct the training as soon as possible.

[Spam](#)

[Not spam](#)













[Forget previous vote](#)

--

David R. Barlag
City Manager's Office
City of Garden Grove
(714) 741-5994



image003.jpg
8 KB

-  **MS Letter to Anaheim re Non-OCEMS EOA Assignment Request 3-19-15.pdf**
66 KB
 -  **MS Letter to Buena Park re Non-OCEMS EOA Assignment Request 3-19-15.pdf**
67 KB
 -  **MS Letter to Costat Mesa re Non-OCEMS EOA Assignment Request 3-19-15.pdf**
66 KB
 -  **MS Letter to Fountain Valley re Non-OCEMS EOA Assignment Request 3-19-15.pdf**
67 KB
 -  **MS Letter to Fullerton re Non-OCEMS EOA Assignment Request 3-19-15.pdf**
66 KB
 -  **MS Letter to Garden Grove re Non-OCEMS EOA Assignment Request 3-19-15.pdf**
67 KB
 -  **MS Letter to Huntington Beach re Non-OCEMS EOA Assignment Request 3-19-15.pdf**
67 KB
 -  **MS Letter to La Habra re Non-OCEMS EOA Assignment Request 3-19-15.pdf**
66 KB
 -  **MS Letter to Laguna Beach re Non-OCEMS EOA Assignment Request 3-19-15.pdf**
67 KB
 -  **MS Letter to Newport Beach re Non-OCEMS EOA Assignment Request 3-19-15.pdf**
66 KB
 -  **MS Letter to Orange re Non-OCEMS EOA Assignment Request 3-19-15 2.pdf**
67 KB
 -  **MS Letter to San Clemente re Non-OCEMS EOA Assignment Request 3-19-15.pdf**
66 KB
-

Zimbra

davidba@ci.garden-grove.ca.us

GGHS Stakeholder Meeting

From : David Barlag <davidba@ci.garden-grove.ca.us>

Tue, Mar 24, 2015 11:45 AM

Subject : GGHS Stakeholder Meeting

📎 1 attachment

To : bweber@ggusd.us, Kristi-a@earthlink.net,
leeannndotgghs@yahoo.com, jrosell@ggusd.us,
sosborne@ggusd.us, James Fischer <jamesf@ci.garden-grove.ca.us>,
Adam Zmija <adamz@ci.garden-grove.ca.us>,
Tony Aquino <tony1@ci.garden-grove.ca.us>,
acorulla@ggusd.us**Bcc :** Allan Roeder <allanr@ci.garden-grove.ca.us>, Bill Murray
<wem@ci.garden-grove.ca.us>, Todd Elgin
<todde@ci.garden-grove.ca.us>

Thank you all for attending the GGHS Stakeholder's meeting today.
I believe we all have similar safety goals in minds and I appreciate the feedback and ideas expressed.

Some of the follow up items are:

Crossing guards:

parents/ student volunteers/ school district employees,
Mr. Osborne , to follow up with School District Risk Management for their issues.
PD has training program available to provide needed training of volunteers.

Traffic Engineering:

to review the placement of the west crosswalk, would include removal of current crosswalk and construction of new crosswalk, including ADA access.
(Costs and feasibility)

to look at intersection control at Seventh and Stanford. Is it effective to make this a three way stop sign control? (Costs and feasibility)

Education:

how can we get the word out to parents and students? Web-site? Mandatory parent sign off?

Provide drop off map link on web-site.

I did follow up on this item and La Quinta High School has a link on their web-site with a site map.

I want to give Traffic Engineering a little time to do some home work, since many of the issues fall into that area.

I will send out an invite for the next follow up meeting.

Lets target 4/23/15 at 9:00 am. again at the school site.

Thanks again

--

David R. Barlag
City Manager's Office
City of Garden Grove
(714) 741-5994



GGHS Agenda 32415.docx

19 KB

Garden Grove High School

Agenda 3/24/2015

- Introduction/ sign in contact information

- Purpose of this meeting

- Discussion from Stakeholders what they see as the issues.

- History
 - The City of Garden Grove received complaints during a City Council meeting.

 - Staff was directed to review the situation
 - PD

 - Traffic Engineering

 - The City again received complaints during a City Council meeting
 - ASB Students and Leann Dotson representing

- What can we do next?
 - Awareness/ Training / Education
 - Improve traffic flow redesign circulation
 - Stricter Enforcement
 - Physical Barriers

- Further Review and follow up

Zimbra

davidba@ci.garden-grove.ca.us

Fire Station 6 CEQA conversation

From : David Barlag <davidba@ci.garden-grove.ca.us>

Tue, Mar 24, 2015 04:08 PM

Subject : Fire Station 6 CEQA conversation

To : Susan Emery <susan1@ci.garden-grove.ca.us>, Lee Marino <leem@ci.garden-grove.ca.us>, Phil Carter <philc@ci.garden-grove.ca.us>, CH3_South <ch3_south@ci.garden-grove.ca.us>

The following is a new meeting request:

Subject: Fire Station 6 CEQA conversation

Organizer: "David Barlag" <davidba@ci.garden-grove.ca.us>

Location: "CH3_South" <ch3_south@ci.garden-grove.ca.us>

Resources: "CH3_South" <ch3_south@ci.garden-grove.ca.us>

Time: Friday, March 27, 2015, 8:15:00 AM - 9:00:00 AM GMT -08:00 US/Canada Pacific

Invitees: susan1@ci.garden-grove.ca.us; leem@ci.garden-grove.ca.us; philc@ci.garden-grove.ca.us

~~*~*~*~*~*~*~*~*

Conversation regarding CEQA requirements for Fire Station #6

Zimbra **davidba@ci.garden-grove.ca.us**

Class lists

From : David Barlag <davidba@ci.garden-grove.ca.us>

Wed, Mar 25, 2015 02:06 PM

Subject : Class lists**To** : Mike Johnson <mikej@ci.garden-grove.ca.us>

Mike going through the list and adding it to a 2015 list of all employees from HR
I cannot find Lea Deguire she is still working correct?

--

David R. Barlag
City Manager's Office
City of Garden Grove
(714) 741-5994

Zimbra

davidba@ci.garden-grove.ca.us

Conference Call with Fire Chiefs and Dr. Stratton.

From : David Barlag <davidba@ci.garden-grove.ca.us>

Thu, Mar 26, 2015 03:02 PM

Subject : Conference Call with Fire Chiefs and Dr. Stratton.**To :** omar sandoval <osandoval@wss-law.com>, Tom Nixon
<tomn@ci.garden-grove.ca.us>**Cc :** Allan Roeder <allanr@ci.garden-grove.ca.us>

Omar,

Chief Spargur participated in a conference call today with Fire Chiefs and Dr. Stratton, regarding the Ameri-care letters.

Aaron Harp CA of Newport Beach volunteered to put out bullet points that he felt needed to be addressed in any response.

I like to current letter that has been prepared by Omar, just thought this may provide some additional information to consider, or not.

I will email Newport Beach Fire to get a copy of those bullet points.

Additionally, Dr. Stratton mentioned that the appeals to the current County process will be heard on 4/14/15 by the BOS.

--

David R. Barlag
City Manager's Office
City of Garden Grove
(714) 741-5994

Zimbra

davidba@ci.garden-grove.ca.us

Re: Conference Call with Fire Chiefs and Dr. Stratton.

From : David Barlag <davidba@ci.garden-grove.ca.us>

Thu, Mar 26, 2015 03:50 PM

Subject : Re: Conference Call with Fire Chiefs and Dr. Stratton.**To :** Omar Sandoval <OSandoval@wss-law.com>**Cc :** Tom Nixon <tomn@ci.garden-grove.ca.us>, Allan Roeder <allanr@ci.garden-grove.ca.us>

Omar,

I just talked to Allan and he said he was fine with you doing this.

David Barlag

From: "Omar Sandoval" <OSandoval@wss-law.com>**To:** "Allan Roeder" <allanr@ci.garden-grove.ca.us>, "David Barlag" <davidba@ci.garden-grove.ca.us>**Cc:** "Tom Nixon" <tomn@ci.garden-grove.ca.us>**Sent:** Thursday, March 26, 2015 3:17:38 PM**Subject:** RE: Conference Call with Fire Chiefs and Dr. Stratton.

Aaron Harp, NB's City Attorney already sent an e-mail with attachments. He asked for a volunteer to draft the response. If you don't have any objections, I can revise the letter I've already prepared (mostly removing the references to GG's impending RFP process) and can then share the work product with the other cities. It may be worthwhile to then get the input of the other city attorneys.

Let me know if you have any objections to my sharing the draft GG letter as proposed. Thanks.
Omar.

Omar Sandoval, Esq.
Woodruff, Spradlin & Smart
555 Anton Boulevard, Suite 1200
Costa Mesa, California 92626
Main:(714) 558-7000
Fax: (714) 835-7787

Direct Dial: (714) 415-1049

Direct Fax: (714) 415-1149

osandoval@wss-law.com

CONFIDENTIALITY NOTICE – This e-mail transmission, and any documents, files or previous e-mail messages attached to it may contain information that is confidential or legally privileged. If you

are not the intended recipient, or a person responsible for delivering it to the intended recipient, you are hereby notified that you must not read this transmission and that any disclosure, copying, printing, distribution or use of any of the information contained in or attached to this transmission is STRICTLY PROHIBITED. If you have received this transmission in error, please immediately notify the sender by telephone at (714) 415-1049 or return e-mail and delete the original transmission and its attachments without reading or saving in any manner. Thank you.

From: David Barlag [mailto:davidba@ci.garden-grove.ca.us]
Sent: Thursday, March 26, 2015 3:02 PM
To: Omar Sandoval; Tom Nixon
Cc: Allan Roeder
Subject: Conference Call with Fire Chiefs and Dr. Stratton.

Omar,
Chief Spargur participated in a conference call today with Fire Chiefs and Dr. Stratton, regarding the Ameri-care letters.
Aaron Harp CA of Newport Beach volunteered to put out bullet points that he felt needed to be addressed in any response.
I like to current letter that has been prepared by Omar, just thought this may provide some additional information to consider, or not.
I will email Newport Beach Fire to get a copy of those bullet points.

Additionally, Dr. Stratton mentioned that the appeals to the current County process will be heard on 4/14/15 by the BOS.

--

David R. Barlag
City Manager's Office
City of Garden Grove
(714) 741-5994

[Spam](#)
[Not spam](#)
[Forget previous vote](#)

--

David R. Barlag
City Manager's Office
City of Garden Grove
(714) 741-5994

Zimbra

davidba@ci.garden-grove.ca.us

Fwd: EMSA 201 Cities from August 2002

From : David Barlag <davidba@ci.garden-grove.ca.us>
Subject : Fwd: EMSA 201 Cities from August 2002
To : Omar Sandoval <osandoval@wss-law.com>

Fri, Mar 27, 2015 10:40 AM

1 attachment

From: "Jeff Spargur" <jspargur@ci.garden-grove.ca.us>
To: davidba@ci.garden-grove.ca.us
Sent: Thursday, March 26, 2015 6:21:51 PM
Subject: Fwd: EMSA 201 Cities from August 2002

Sent from my iPhone

Begin forwarded message:

From: "LaTendresse, Jeff FD" <jlatendresse@lagunabeachcity.net>
To: Randy Bruegman <rbruegman@anaheim.net>, Scott Poster <sposter@nbfd.net>, Tony Coppolino <tony.coppolino@fountainvalley.org>, Wolfgang Knabe <firechief@fullertonfire.org>, "jspargur@ci.garden-grove.ca.us" <jspargur@ci.garden-grove.ca.us>, Dan Stefano <dan.stefano@costamesaca.gov>, Jeff Bowman <jeffbowman@ocfa.org>, Patrick Dibb <pdibb@cityoforange.org>, Patrick McIntosh <patrick.mcintosh@surfcity-hb.org>, Warren Hartley <warrenh@garden-grove.org>, Bill Kolberg <william.kolberg@disney.com>, "LaTendresse, Jeff FD" <jlatendresse@lagunabeachcity.net>
Subject: EMSA 201 Cities from August 2002

All,

As part of our contract with Doctor's Ambulance there is a section referenced from EMSA dated August 12, 2002. It does list most of the cities in Orange County as having 201 rights. Have any of you seen this before? Thanks,

Jeff LaTendresse, Fire Chief
Laguna Beach Fire Department
505 Forest Avenue
Laguna Beach, CA 92651

Office: (949) 497-0381
jlatendresse@lagunabeachcity.net

--

David R. Barlag
City Manager's Office
City of Garden Grove
(714) 741-5994



EMSA 201 Cities 2002.pdf

1 MB

201 Cities Listed By LEMSA

LEMSA	City/FD	Comments
Alameda	Alameda City	
	Albany	
	Berkeley	
	Piedmont	
Coastal Valleys	Bodega Bay	
	Covelo	
	Elk	
	Laytonville	
	Napa	Napa Fire has "201 rights" but chooses to contract out ambulance service. Elk Fire and Covelo fire have a single BLS transport unit each however unsure about "201" status. S/W Kent Coxon at Coastal Valley EMS.
	Petaluma	
	Russian River	
Contra Costa	Sonoma	
	Ukiah	
	Moraga/Orinda	EMS Agency does not recognize with "201 rights".
	San Ramon	This Department competitively bids for transport. Former hospital based program.

Agreement Between the City of Laguna Beach and Herren Enterprises, Inc.
 For Provision of Fire/EMS Emergency Ambulance Transportation
 and Related Services Within the City of Laguna Beach

LEMSA	City/FD	Comments
El Dorado	Cameron Park Diamond Springs	These Fire Departments offer ALS transport, however are not recognized by the county in having 201 rights. These Fire Departments offer ALS transport, however are not recognized by the county in having 201 rights.
	El Dorado County El Dorado Hills Georgetown	These Fire Departments offer ALS transport, however are not recognized by the county in having 201 rights.
Fresno, Kings, Mad	Coalinga Sanger Selma	
Imperial	None	
Inland Counties	Hesperia Rialto	
Kern	None	

Agreement Between the City of Laguna Beach and Harren Enterprises, Inc.
For Provision of Fire/EMS/Emergency Ambulance Transportation
and Related Services Within the City of Laguna Beach

LEMSA	City/FD	Comments
Los Angeles	Alhambra	
	Arcadia	
	Avalon	County FD Lifeguard Division.
	Beverly Hills	
	Burbank	
	Compton	
	Covina	County/Provider Exclusive Operating Area Agreement with AMR of Southern California for BLS.
	Culver City	
	Downey	
	El Segundo	
	Gardena	County Fire Department. Mc Cormick Ambulance is the interim transport provider.
	Glendale	
	Hawthorne	LACO FD provides fire and ALS service to these cities but they kept their 201 rights for ambulance contracts.
	Hermosa Beach	
	Inglewood	County Fire Department. AMR is the interim transport provider.
	La Verne	
	Long Beach	Long Beach Fire Department (also provides emergency services for the City of Signal Hill – contracts with AMR for BLS transport services.
	Long Beach	
	Los Angeles	
	Los Angeles	Los Angeles Fire Department (also provides ALS/transport services for the City of San Fernando)

Agreement Between the City of Laguna Beach and Heinen Enterprises, Inc.
For Provision of Fire/EMS Emergency Ambulance Transportation
and Related Services Within the City of Laguna Beach

LEMSA	City/FD	Comments
	Los Angeles County	LACO Fire Department which includes the 57 cities who contract for service with us and all the unincorporated areas have retained 201 rights. It is interesting that although some cities that come in may or may not have their rights, they are blanketed under our system Regarding 201 issues. The reason it is interesting is that some would consider our annexation of the Cities after 1980 a change in delivery models and hence cause a loss of rights and the need for a contract.
	Lynwood	LACO FD provides fire and ALS service to these cities but they kept their 201 rights for ambulance contracts.
	Manhattan Beach	
	Monterey Park	
	Pasadena	
	Pomona	LACO FD provides fire and ALS service to these cities but they kept their 201 rights for ambulance contracts.
	San Fernando	City of Los Angeles Fire Department.
	San Gabriel	
	San Marino	
	Santa Monica	
	Sierra Madre	Sierra Madre Fire Department (volunteer EMTs only).
	Signal Hill	City of Long Beach Fire Department.
	South Pasadena	
	Torrance	Torrance Fire Department – Gerber Ambulance provides BLS transport.
	Vernon	City of Vernon, AMR Metro South provides ALS staffing and transport.

Agreement Between the City of Laguna Beach and Herron Enterprises, Inc.
 For Provision of Fire/EMS Emergency Ambulance Transportation
 and Related Services Within the City of Laguna Beach

LEMSA	City/FD	Comments
	West Covina	West Covina Fire Department – AMR San Gabriel Valley Division and Schaefer Ambulance Services provide BLS transport services.
Marin	Marin Marin County Fire Novato San Rafael	
Merced	None	
Monterey	Carmel	These departments have formed a JPA and provide ALS transport service with "201 rights". S/W Dave Bezouska
	Carmel Valley Fire P	These departments have formed a JPA and provide ALS transport service with "201 rights". S/W Dave Bezouska
	Mid Carmel Fire Prot	
Mountain Valley	None	S/W Rick Jones
North Coast	None	
Northern California	No Data	

LEMSA	City/FD	Comments
Orange County		
	Anaheim	
	Brea	
	Costa Mesa	Unconfirmed.
	Fountain Valley	Unconfirmed.
	Fullerton	
	Garden Grove	Unconfirmed.
	Huntington Beach	ALS/BLS since 1993 (Unconfirmed).
	La Habra	ALS/BLS since 1996 (Unconfirmed).
	Laguna Beach	
	Newport Beach	ALS/BLS since 1996 (Unconfirmed).
	Orange City	ALS/BLS since 1996 (Unconfirmed).
	San Clemente	ALS/BLS since 1995 (Unconfirmed).
	Santa Ana	ALS/BLS since 1976.
Riverside		
	Riverside City	
Sacramento		
	Elk Grove	
	Folsom	
	Galt	
	Sacramento City	Fire Departments offer ALS transport. The county released the rights to transport agreements to the individual cities. The county still makes the final decision.
	Sacramento Metro	
San Benito		
	None	

LEMSA	City/FD	Comments
San Diego	Carlsbad Chulla Vista County Service Area El Cajon Escondido Grossmont Hospital North County Fire Pr Oceanside Poway Vista	
San Francisco	San Francisco	
San Joaquin	Rippon	
San Luis Obispo	No Data	
San Mateo	South San Francisco	
Santa Barbara	No Data	
Santa Clara	Palo Alto	
Santa Cruz	None	
Sierra-Sacramento	None	Some FD providers, but none with 201 rights.
Solano	Vacaville	
Tulare	Dinuba Exeter	Ambulance Special District.

Agreement Between the City of Laguna Beach and Herren Enterprises, Inc.
For Provision of Fire/EMS Emergency Ambulance Transportation
and Related Services Within the City of Laguna Beach

LEMSA	City/FD	Comments
Tuolumne	None	
Ventura	None	

Agreement Between the City of Laguna Beach and Herren Enterprises, Inc.
For Provision of Fire/EMS Emergency Ambulance Transportation
and Related Services Within the City of Laguna Beach

EXHIBIT B

[SEE ATTACHED MAP]

Zimbra

davidba@ci.garden-grove.ca.us

ad valorem

From : David Barlag <davidba@ci.garden-grove.ca.us>

Mon, Mar 30, 2015 01:45 PM

Subject : ad valorem

To : Lucia Medina <luciam@ci.garden-grove.ca.us>

The following is a new meeting request:

Subject: ad valorem

Organizer: "David Barlag" <davidba@ci.garden-grove.ca.us>

Time: Tuesday, March 31, 2015, 9:00:00 AM - 10:00:00 AM GMT -08:00 US/Canada Pacific

Invitees: luciam@ci.garden-grove.ca.us

~~*~*~*~*~*~*~*~*

Zimbra

davidba@ci.garden-grove.ca.us

Paramedic Ad Valorem Tax

From : David Barlag <davidba@ci.garden-grove.ca.us>

Tue, Mar 31, 2015 12:59 PM

Subject : Paramedic Ad Valorem Tax

To : Kingsley Okereke <kingsley@ci.garden-grove.ca.us>, Mike Mcclellan <mikem@ci.garden-grove.ca.us>, Lucia Medina <luciam@ci.garden-grove.ca.us>, CH3_Law_Library <ch3_law_library@ci.garden-grove.ca.us>

The following is a new meeting request:

Subject: Paramedic Ad Valorem Tax

Organizer: "David Barlag" <davidba@ci.garden-grove.ca.us>

Location: "CH3_Law_Library" <ch3_law_library@ci.garden-grove.ca.us>

Resources: "CH3_Law_Library" <ch3_law_library@ci.garden-grove.ca.us>

Time: Thursday, April 2, 2015, 9:00:00 AM - 10:00:00 AM GMT -08:00 US/Canada Pacific

Invitees: kingsley@ci.garden-grove.ca.us; mikem@ci.garden-grove.ca.us; luciam@ci.garden-grove.ca.us

~~*~*~*~*~*~*~*~*

Conversation regarding proposed changes to PM ad valorem tax calculations.

Zimbra

davidba@ci.garden-grove.ca.us

Paramedic Ad Valorem Tax

From : David Barlag <davidba@ci.garden-grove.ca.us>

Tue, Mar 31, 2015 02:13 PM

Subject : Paramedic Ad Valorem Tax

To : Kingsley Okereke <kingsley@ci.garden-grove.ca.us>, Mike Mcclellan <mikem@ci.garden-grove.ca.us>, Lucia Medina <luciam@ci.garden-grove.ca.us>, CH3_Law_Library <ch3_law_library@ci.garden-grove.ca.us>

The following meeting has been modified:

Subject: Paramedic Ad Valorem Tax

Organizer: "David Barlag" <davidba@ci.garden-grove.ca.us>

Location: "CH3_Law_Library" <ch3_law_library@ci.garden-grove.ca.us>

Resources: "CH3_Law_Library" <ch3_law_library@ci.garden-grove.ca.us> (CH3_Law_Library)

Time: Thursday, April 2, 2015, 10:00:00 AM - 11:00:00 AM GMT -08:00 US/Canada Pacific [MODIFIED]

Invitees: kingsley@ci.garden-grove.ca.us; mikem@ci.garden-grove.ca.us; luciam@ci.garden-grove.ca.us

~~*~*~*~*~*~*~*~*

Conversation regarding proposed changes to PM ad valorem tax calculations.

Zimbra

davidba@ci.garden-grove.ca.us

FYI I will be attending OCEMO in Am

From : David Barlag <davidba@ci.garden-grove.ca.us>

Wed, Apr 01, 2015 04:33 PM

Subject : FYI I will be attending OCEMO in Am

To : Allan Roeder <allanr@ci.garden-grove.ca.us>

Allan,
I will be at the OCEMO meeting in Laguna Niguel during the morning 4/2/15

--

David R. Barlag
City Manager's Office
City of Garden Grove
(714) 741-5994

Zimbra

davidba@ci.garden-grove.ca.us

GGHS Traffic Meeting

From : David Barlag <davidba@ci.garden-grove.ca.us>

Mon, Apr 06, 2015 09:50 AM

Subject : GGHS Traffic Meeting

To : bweber <bweber@ggusd.us>, Kristi-a <kristi-a@earthlink.net>, leeandotsongghs <leeandotsongghs@yahoo.com>, jrosell <jrosell@ggusd.us>, sosborne <sosborne@ggusd.us>, James Fischer <jamesf@ci.garden-grove.ca.us>, Adam Zmija <adamz@ci.garden-grove.ca.us>, Tony Aquino <tony1@ci.garden-grove.ca.us>, acorulla <acorulla@ggusd.us>

The following is a new meeting request:

Subject: GGHS Traffic Meeting

Organizer: "David Barlag" <davidba@ci.garden-grove.ca.us>

Location: At the school site

Time: Thursday, April 23, 2015, 9:00:00 AM - 10:00:00 AM GMT -08:00 US/Canada Pacific

Invitees: bweber@ggusd.us; Kristi-a@earthlink.net; leeandotsongghs@yahoo.com; jrosell@ggusd.us; sosborne@ggusd.us; jamesf@ci.garden-grove.ca.us; adamz@ci.garden-grove.ca.us; tony1@ci.garden-grove.ca.us; acorulla@ggusd.us

~~*~*~*~*~*~*~*~*

Mr. Osborne,
Can you confirm a room for our use?

Thank you,
David Barlag

Zimbra

davidba@ci.garden-grove.ca.us

City Manager Briefing GGHS

From : David Barlag <davidba@ci.garden-grove.ca.us>

Mon, Apr 06, 2015 10:01 AM

Subject : City Manager Briefing GGHS

To : Allan Roeder <allanr@ci.garden-grove.ca.us>, Tony Aquino <tony1@ci.garden-grove.ca.us>, Adam Zmija <adamz@ci.garden-grove.ca.us>

The following is a new meeting request:

Subject: City Manager Briefing GGHS

Organizer: "David Barlag" <davidba@ci.garden-grove.ca.us>

Location: CM Office

Time: Monday, April 13, 2015, 9:00:00 AM - 9:30:00 AM GMT -08:00 US/Canada Pacific

Invitees: allanr@ci.garden-grove.ca.us; tony1@ci.garden-grove.ca.us; adamz@ci.garden-grove.ca.us

~~*~*~*~*~*~*~*~*

Zimbra **davidba@ci.garden-grove.ca.us**

Refinancing existing City Bonds

From : David Barlag <davidba@ci.garden-grove.ca.us>

Fri, Apr 10, 2015 10:42 AM

Subject : Refinancing existing City Bonds**To :** Kingsley Okereke <kingsley@ci.garden-grove.ca.us>, Allan Roeder <allanr@ci.garden-grove.ca.us>**Cc :** Todd Elgin <todde@ci.garden-grove.ca.us>, warrenh <warrenh@ci.garden-grove.ca.us>, Jeff Spargur <jspargur@ci.garden-grove.ca.us>, Nathan Brady <nathanb@ci.garden-grove.ca.us>, Bill Murray <wem@ci.garden-grove.ca.us>

Kingsley,

I was reviewing the 2015 Strategic Plan as discussed at the 4/1/15 Central Management meeting.

A key element of the future fire station construction and PD lobby remodel is the money to do it.

It was discussed that we need to pursue the refinancing of the City bonds as soon as possible.

The planning process for the fire station and PD lobby remodel do not have to be in place prior to refinancing.

I am available if there is anything I can do to help facilitate.

--

David R. Barlag
City Manager's Office
City of Garden Grove
(714) 741-5994

Zimbra

davidba@ci.garden-grove.ca.us

Re: 2014 EMPG: OCEMO Meeting Attendance

From : David Barlag <davidba@ci.garden-grove.ca.us>

Fri, Apr 10, 2015 06:48 PM

Subject : Re: 2014 EMPG: OCEMO Meeting Attendance**To :** Jeff Spargur <jspargur@ci.garden-grove.ca.us>

Jeff

Confirm that I was counted for attending in March and April.

David R. Barlag

On Apr 10, 2015, at 6:45 PM, Jeff Spargur <jspargur@ci.garden-grove.ca.us> wrote:

Sent from my iPhone

Begin forwarded message:

From: "ANDERSON, MICHELLE L" <MANDERSON@ocsd.org>**Date:** April 10, 2015 at 5:21:42 PM PDT**To:** "jspargur@ci.garden-grove.ca.us" <jspargur@ci.garden-grove.ca.us>**Cc:** "OSBORN, VICTORIA A" <VOsborn@ocsd.org>, "ERDNER, MARGARET E" <perdner@ocsd.org>**Subject: 2014 EMPG: OCEMO Meeting Attendance**

Good evening,

You may recall that Orange County requires that each city participating in the Emergency Management Performance Grant attend at least half of the Orange County Emergency Management Organization's (OCEMO) meetings held during the year. As we near the end of the current grant performance period, we are reviewing the OCEMO sign-in rosters to ensure cities have met this requirement by the time the grant closes.

This email is to confirm that you or a member of your city has attended 3 of the 10 OCEMO meetings held this fiscal year. There are only two more meetings planned before the end of the fiscal year (May and June) which means that your city may not be eligible to receive funding.

Please contact me if the above count is not correct, if you participated in subcommittee activities which you would like to count towards the meeting requirements, or if your city had extenuating circumstances which kept someone from attending.

Regards,
Michelle Anderson
Orange County Sheriff's Department
Emergency Management Division
EOC: 714-628-7158
Fax: 714-628-7054
Email: manderson@ocsd.org

Zimbra

davidba@ci.garden-grove.ca.us

Fwd: 800 MHz CCCS Financing Update

From : David Barlag <davidba@ci.garden-grove.ca.us> Mon, Apr 13, 2015 11:19 AM
Subject : Fwd: 800 MHz CCCS Financing Update
To : Kingsley Okereke <kingsley@ci.garden-grove.ca.us>

From: "Allan Roeder" <allanr@ci.garden-grove.ca.us>
To: "David Barlag" <davidba@ci.garden-grove.ca.us>
Sent: Friday, April 10, 2015 8:57:35 AM
Subject: Fwd: 800 MHz CCCS Financing Update

fyi

----- Forwarded Message -----

From: "Robert Stoffel" <Robert.Stoffel@comm.ocgov.com>
To: "Robert Stoffel" <Robert.Stoffel@comm.ocgov.com>
Sent: Friday, April 10, 2015 8:42:29 AM
Subject: 800 MHz CCCS Financing Update

Greetings, 800 MHz Committee members . John Pietig asked that I send you this update:

Yesterday afternoon I attended the County's Public Financing Advisory Committee meeting. At the meeting the committee heard a request from the County Executive Office for the financing for the 800 MHz CCCS upgrade and selection of KNN Public Finance as financial advisor and Citigroup Global Markets as underwriter for the proposed financing. The presentation was given by Suzanne Luster who did an outstanding job explaining the project and reason for the request. Frank Kim (County Financial Officer) and I answered specific questions from the committee. It seemed to go well, although the committee did have concerns with the County financing their subscriber equipment (due to the shorter life expectancy of that equipment). The committee approved the request in concept, and CEO Public Finance will continue working on the overall plan. The item will likely be brought to the Board of Supervisors in May. As an FYI, at this time we have 10 cities that have expressed an interest in joining the county with financing the backbone portion of the project (Anaheim, Buena Park, Fullerton, Garden Grove, La Habra, Laguna Niguel, Orange, Placentia, Santa Ana, Yorba Linda).

Thank-you,

Robert

Robert A. Stoffel

Director, Communications & Technology Division

Orange County Sheriff's Department

840 N. Eckhoff St. Suite 104

Orange, CA 92868-1021

(714) 704-7919 - Telephone

(714) 704-7902 - Fax

Robert.Stoffel@comm.ocgov.com - Email

P Please consider the environment before printing this e-mail

--

David R. Barlag
City Manager's Office
City of Garden Grove
(714) 741-5994

Zimbra

davidba@ci.garden-grove.ca.us

Contingency Plan 800 MHz Finance

From : David Barlag <davidba@ci.garden-grove.ca.us>

Tue, Apr 14, 2015 09:27 AM

Subject : Contingency Plan 800 MHz Finance**To** : Kingsley Okereke <kingsley@ci.garden-grove.ca.us>

Kingsley,

I forwarded you an email yesterday from Allan, "800 MHz CCCS Finance Update"
It appears the County is moving forward and expects to have numbers sometime in May.

I just want to know if there is any flex, should the County's numbers come back poorly.

Can we buy off for the year, \$129,608 then look harder into our own financing?

I am still outstanding a request from Motorola for financing as well. The Rep has been out of the office and is due back today.

I will follow up there.

--

David R. Barlag
City Manager's Office
City of Garden Grove
(714) 741-5994

Zimbra

davidba@ci.garden-grove.ca.us

Re: Hot Red s for GG

From : David Barlag <davidba@ci.garden-grove.ca.us> Wed, Apr 15, 2015 09:25 AM
Subject : Re: Hot Red s for GG 1 attachment
To : Rebecca Meeks <rebeccam@ci.garden-grove.ca.us>
Cc : David Barlag <davidba@ci.garden-grove.ca.us>, Courtney Allison <courta@ci.garden-grove.ca.us>, Ben Stauffer <stauffer@ci.garden-grove.ca.us>
Bcc : Todd Elgin <todde@ci.garden-grove.ca.us>

Just to put everyone on the same page, I had a conversation with Rebecca on 3/26/15. I believe that PD should be in the drivers seat from here out with regards to the purchase and installation. I know Courtney has been working on putting it into supplementals. I am here if I can be of any help.

David R. Barlag

On Mar 26, 2015, at 7:12 AM, Rebecca Meeks <rebeccam@ci.garden-grove.ca.us> wrote:

Hi Dave,

Will you be placing the order with Motorola or is that something I will need to do? Also, we will have OCC handle the installation, so I will give them a call to coordinate if we are getting them in July.

Rebecca
X-5904

From: "David Barlag" <davidba@ci.garden-grove.ca.us>
To: "Ben Stauffer" <stauffer@ci.garden-grove.ca.us>, "Rebecca Meeks" <rebeccam@ci.garden-grove.ca.us>, "Courtney Allison" <courta@ci.garden-grove.ca.us>
Sent: Thursday, March 19, 2015 3:02:42 PM
Subject: Fwd: Hot Red s for GG

Hello All,
So the Hot Reds went through last Council meeting 3/10/15.
See the attached email string as far timing.
I am not sure PD's plan for the installation of these radios.
You should probably figure that portion into the supplemental as well.
Is the install through OCC or an outside contractor?
Just don't want you to get these radios and have no means to install.

Give me a call if I can help,
David Barlag
714 741-5994

From: "Kim Caplan" <Kim.Caplan@motorolasolutions.com>
To: "David Barlag" <davidba@ci.garden-grove.ca.us>
Sent: Thursday, March 19, 2015 2:30:59 PM
Subject: RE: Hot Red s for GG

Hi Dave,

The attached quote has been updated. The pricing didn't change, we just had change how the parts were ordered on the motorcycle configuration.

If you need the radios in the beginning of July what you could do is place an order in May or June with instructions not to ship until after July 1st. We don't invoice until the radios ship and it usually takes 4-8 weeks to build the radios depending on the factory workload.

Yes, these radios are produced and have been shipping.

Kim Caplan

Senior Account Manager
Motorola Solutions, Inc.
O: 760-630-5199
M: 858-442-3979

<image001.png>

From: David Barlag [<mailto:davidba@ci.garden-grove.ca.us>]
Sent: Thursday, March 19, 2015 2:05 PM
To: Kim Caplan
Subject: Hot Red s for GG

Hi Kim,
So is the quote 021315GGAPXHRR,
A good number for the GG purchase?
How can we put this in the pipe for kick off in July?
It was approved for purchase at our last Council Meeting 3/10/15 in the
15/16 budget year.
Are these radio's currently produced?

--

David R. Barlag
City Manager's Office
City of Garden Grove
(714) 741-5994

NOTE: This message was trained as non-spam. If this is wrong, please correct the training as soon as possible.

[Spam](#)

[Not spam](#)

[Forget previous vote](#)

--

David R. Barlag
City Manager's Office
City of Garden Grove
(714) 741-5994



Zimbra

davidba@ci.garden-grove.ca.us

Re: City of Garden Grove finance request

From : David Barlag <davidba@ci.garden-grove.ca.us>
Subject : Re: City of Garden Grove finance request
To : Kim Caplan <kim.caplan@motorolasolutions.com>

Thu, Apr 16, 2015 04:58 PM

1 attachment

I will work on that next week.
David

From: "Kim Caplan" <kim.caplan@motorolasolutions.com>
To: "David Barlag" <davidba@ci.garden-grove.ca.us>
Sent: Thursday, April 16, 2015 4:43:14 PM
Subject: Re: City of Garden Grove finance request

Hi David,

I started to go through and count up the radios on the inventory list that you sent me more than once, but I'm not sure if the numbers will be accurate. I don't know for example what a radio highlighted in blue means. It could mean that the radio is no longer active, I'm just not sure.

Can you please just send me a brief summary of the quantities and types of radios that you currently have? For example Quantity (45) XTS3000 Model 3 Portables with encryption or Quantity (20) Astro Spectra Mobiles with 07 Control Heads and encryption.

As soon as I have this information I can finish things up.

Best Regards,

Kim Caplan

On Thu, Apr 16, 2015 at 2:04 PM, David Barlag <davidba@ci.garden-grove.ca.us> wrote:

Hi Kim,

I know you have been out, just want to confirm you are working on this for GG?

David

From: "Kim Caplan" <Kim.Caplan@motorolasolutions.com>
To: "David Barlag" <davidba@ci.garden-grove.ca.us>
Cc: "Kingsley Okereke" <kingsley@ci.garden-grove.ca.us>
Sent: Tuesday, March 10, 2015 7:38:00 PM
Subject: RE: City of Garden Grove finance request

David,

It was nice to meet you as well. Can you please provide me with the following information?

1) Do you need exact numbers for the radio equipment or do you just want to use the spreadsheet the County has with their estimates for now? If exact numbers can you please provide portable radio quantities and accessories required. I believe the mobiles are covered in the attached proposal, but if you could please confirm the quantities and that you don't need any non-hot red radios that would be great.

2) Same question as #1

3) Can only provide a 10 year lease without any backbone for consoles and radios

4) Same question as #1

Best Regards,

Kim Caplan

Senior Account Manager

Motorola Solutions, Inc.

O: 760-630-5199

M: 858-442-3979



MOTOROLA SOLUTIONS

From: David Barlag [mailto:davidba@ci.garden-grove.ca.us]

Sent: Tuesday, March 10, 2015 1:51 PM

To: Kim Caplan

Cc: Kingsley Okereke

Subject: City of Garden Grove finance request

Kim,

It was nice meeting you the other day at the Governance Meeting.

Can I ask for a quote for Garden Grove with two term lengths and two options for each term.

So I am asking for 4 quotes;

1)10 year term

Console and Equipment

2)10 year term

Console and Equipment plus Backbone

3)15 year term

Console and Equipment

4)15 year term

Console and Equipment plus Backbone

If you need any additional information, let me know.

We are just exploring our options.

Thank you,

--

David R. Barlag
City Manager's Office
City of Garden Grove
[\(714\) 741-5994](tel:(714)741-5994)

NOTE: This message was trained as non-spam. If this is wrong, please correct the training as soon as possible.

[Spam](#)

[Not spam](#)

[Forget previous vote](#)

--

David R. Barlag
City Manager's Office
City of Garden Grove
[\(714\) 741-5994](tel:(714)741-5994)

NOTE: This message was trained as non-spam. If this is wrong, please correct the training as soon as possible.

[Spam](#)

[Not spam](#)

[Forget previous vote](#)

--

David R. Barlag
City Manager's Office
City of Garden Grove
(714) 741-5994



MOTOROLA SOLUTIONS

image001.png

6 KB

Zimbra

davidba@ci.garden-grove.ca.us

draft agenda for thursday with GGHS

From : David Barlag <davidba@ci.garden-grove.ca.us>

Tue, Apr 21, 2015 12:33 PM

Subject : draft agenda for thursday with GGHS 1 attachment**To** : Adam Zmija <adamz@ci.garden-grove.ca.us>, Tony Aquino
<tony1@ci.garden-grove.ca.us>

Take a look let me know if you want to change something

--

David R. Barlag
City Manager's Office
City of Garden Grove
(714) 741-5994

**GGHS Agenda 42315.docx**20 KB

Garden Grove High School

Agenda 4/23/2015

- Introduction/ sign in /contact information

- Additional Information background
 - What the City provides for crossing guards
 - When the crossing guards were last reviewed

- Review of last meeting where we left off
 - School district was going to go back and check with risk management
 - Admin/teacher use
 - Volunteer use
 - Student use

 - City /Traffic Management
 - Stop sign traffic study (Stanford and Seventh)
 - Review crosswalk locations
 - Fence in median (trial period)

 - Outreach
 - Can the School District reach out to the First Baptist Church of GG
 - Agreement for use of their parking lot North side as a drop zone for students
 - Follow up with a map on web site if agreement is reached
 - Additional outreach and education for students and parents
 - I have contact information if you want it

- Follow up/ additional items

Zimbra

davidba@ci.garden-grove.ca.us

Paramedic Ad Valorem Tax

From : David Barlag <davidba@ci.garden-grove.ca.us>

Thu, Apr 23, 2015 11:19 AM

Subject : Paramedic Ad Valorem Tax 1 attachment**To** : Mike McClellan <mikem@ci.garden-grove.ca.us>, Lucia Medina-Whittaker <luciam@ci.garden-grove.ca.us>**Cc** : Kingsley Okereke <kingsley@ci.garden-grove.ca.us>, Allan Roeder <allanr@ci.garden-grove.ca.us>

Mike and Lucia,

I have talked with both Allan and Kingsley, they are good with using this updated formula for the justification of costs

of the Paramedic Ad Valorem Tax for the 2015/2016 budget year.

We will be using the first sheet of the attachment, which does not remove the non resident fee reimbursement.

Thanks for the work updating.

--

David R. Barlag
City Manager's Office
City of Garden Grove
(714) 741-5994

 **PM Program Cost Analysis_FY 15-16_ATTACHMENT_4.20.15.xlsx**
34 KB

PARAMEDIC PROGRAM COST ANALYSIS
PARAMEDIC TAX REIMBURSEMENT
FY 2015 - 2016

5 Yr. Average Total Calls for Service	11,531
5 Yr. Average Medical Aid Calls	10,015
5 Yr. Average Paramedic Unit Service Calls	6,154
5 Yr. Average Paramedic Unit Service Call Ratio	0.5337

Paramedic Program Cost Analysis

	<u>Full Cost</u>
Direct Cost (Division 52)	
Labor	4,138,642
Non-Labor	127,700
Equip Pool (Paramedic Trucks)	83,508
Insurance	7,805
Telephones	4,349
	<u>4,362,004</u>
Other Allocable Costs	
Dispatch Costs 53% of \$631,529	337,075
Fire Engines 53% of \$1,533,403	818,446
Captains (18) 53% of \$3,226,662	1,722,215
<i>Captain OT</i> 53% of \$859,292	458,643
Engineers (15) 53% of \$2,130,945	1,137,381
<i>Engineer OT</i> 53% of \$158,366	84,527
Training Support 53% of \$35,900	19,161
Inter-City Charges 53% of \$288,396	153,930
	<u>4,731,379</u>
Gross Paramedic Program Cost	<u>9,093,383</u>
Reimbursements	
Paramedic Personnel Reimbursement	255,000
Medical Supply Reimbursement	141,000
Non-Resident Reimbursement	252,000
	<u>648,000</u>
Net Paramedic Program Cost	<u><u>8,445,383</u></u>

Zimbra

davidba@ci.garden-grove.ca.us

Re: FS update

From : David Barlag <davidba@ci.garden-grove.ca.us>

Tue, Apr 28, 2015 09:19 AM

Subject : Re: FS update**To :** Gary Chubb <gchubb@griffinholdings.net>

Forward, No sideways yes,

So the Public safety Infrastructure including FS 6 in being placed into a 2015 Strategic Plan for the Council, this will go to Council on May 12 for adoption. This Plan earmarks the date of Dec/17 for completion of FS 6.

Fire is the lead on the project and I will continue to work on the project as a resource. The new Chief comes on board this week so we will keep pushing forward.

David Barlag

From: "Gary Chubb" <gchubb@griffinholdings.net>
To: "David Barlag" <davidba@ci.garden-grove.ca.us>
Sent: Tuesday, April 28, 2015 7:56:27 AM
Subject: FS update

Hi there.

Any forward progress being made to advance the effort? Just checking in...

Thanks!!!!

Gary Chubb
Griffin Structures, Inc.

--

BEGIN-ANTISPAM-VOTING-LINKS

NOTE: This message was trained as non-spam. If this is wrong, please correct the training as soon as possible.

Teach CanIt if this mail (ID 010lqPvXO) is spam:

Spam: <http://spam.ci.garden-grove.ca.us/b.php?i=010lqPvXO&m=64707d865a51&c=s>

Not spam: <http://spam.ci.garden-grove.ca.us/b.php?i=010lqPvXO&m=64707d865a51&c=n>

Forget vote: <http://spam.ci.garden-grove.ca.us/b.php?i=010lqPvXO&m=64707d865a51&c=f>

END-ANTISPAM-VOTING-LINKS

--

David R. Barlag
City Manager's Office
City of Garden Grove
(714) 741-5994

Zimbra

davidba@ci.garden-grove.ca.us

Re: FS update

From : David Barlag <davidba@ci.garden-grove.ca.us>

Tue, Apr 28, 2015 02:01 PM

Subject : Re: FS update

📎 1 attachment

To : Gary Chubb <gchubb@griffinholdings.net>

Hey Gary we are making changes currently to the Muni Code to allow for it. I certainly think we will head that direction.

From: "Gary Chubb" <gchubb@griffinholdings.net>
To: "David Barlag" <davidba@ci.garden-grove.ca.us>
Sent: Tuesday, April 28, 2015 1:53:33 PM
Subject: RE: FS update

Thank you Dave. Do you think this will be delivered using the new Design-Build method?



Gary Chubb | Executive Vice President/Director of Operations

GRIFFIN STRUCTURES, INC.

385 Second Street, Laguna Beach, CA 92651 | T 949-497-9000 x205 | F 949-497-8883 | C 949-413-6890

www.griffinstructures.com P Do you really need to print this email? Please consider our environment.

CONFIDENTIALITY NOTICE: This e-mail transmission, and any documents, files or previous email messages attached to it, may contain confidential information. If you are not the intended recipient, or a person responsible for delivering it to the intended recipient, you are hereby notified that any disclosure, copying, distribution or use of any of the information contained in or attached to this message is **STRICTLY PROHIBITED**. If you have received this transmission in error, please immediately notify us by reply e-mail at gchubb@griffinholdings.net or by telephone at 949.497.9000 and destroy the original transmission and attachments without reading them or saving them to disk. Thank you. **WARNING:** This electronic e-mail message is furnished without guarantee of compatibility with recipients' hardware or software and may contain undetected viruses or other damaging material. It is recommended that this e-mail message and any attachments be checked prior to viewing or use. Sender assumes no responsibility for damage to user's equipment or property as a result of receiving this e-mail message and/or using or viewing its contents.

From: David Barlag [mailto:davidba@ci.garden-grove.ca.us]

Sent: Tuesday, April 28, 2015 9:19 AM
To: Gary Chubb
Subject: Re: FS update

Forward, No sideways yes,

So the Public safety Infrastructure including FS 6 in being placed into a 2015 Strategic Plan for the Council,
this will go to Council on May 12 for adoption. This Plan earmarks the date of Dec/17 for completion of FS 6.

Fire is the lead on the project and I will continue to work on the project as a resource. The new Chief comes on board this week so we will keep pushing forward.

David Barlag

From: "Gary Chubb" <gchubb@griffinholdings.net>
To: "David Barlag" <davidba@ci.garden-grove.ca.us>
Sent: Tuesday, April 28, 2015 7:56:27 AM
Subject: FS update

Hi there.

Any forward progress being made to advance the effort? Just checking in...

Thanks!!!!

Gary Chubb
Griffin Structures, Inc.

--

BEGIN-ANTISPAM-VOTING-LINKS

NOTE: This message was trained as non-spam. If this is wrong, please correct the training as soon as possible.

Teach CanIt if this mail (ID 010IqPvXO) is spam:

Spam:

Not spam:

Forget vote:

END-ANTISPAM-VOTING-LINKS

--

David R. Barlag
City Manager's Office
City of Garden Grove
(714) 741-5994

NOTE: This message was trained as non-spam. If this is wrong, please correct the training as soon as possible.

[Spam](#)

[Not spam](#)

[Forget previous vote](#)

--

David R. Barlag
City Manager's Office
City of Garden Grove
(714) 741-5994



image001.jpg

2 KB

City of Garden Grove

INTER-DEPARTMENT MEMORANDUM

To: Allan L. Roeder
Dept: Interim City Manager
Subject: GARDEN GROVE HIGH SCHOOL
STUDENT SAFETY UPDATE

From: David R. Barlag
Dept: CM Office
Date: April 28, 2015

There are concerns regarding student safety around Garden Grove High School (GGHS). The purpose of this memo is to provide an update of the current status.

To date, staff has met twice in an all hands meeting with the School District, School Administrators, and parents representing the Parent Teacher Student Association (PTSA).

The first meeting was on 3/24/15, City Staff listened to the concerns as they were expressed from members of the PTSA and Administration on site.

Primary issues raised by the school site were:

- Crosswalk locations,
- Use of crossing guards,
- Possibility of an additional stop sign at Seventh and Stanford.

Other points brought up by the City Staff included:

- Student/parent education through the school's website,
- Possible use of a traffic plan posted on the website,
- Median fence to prevent mid-street jay walking.

Both sides agreed to go back and research these issues further:

- The school was going to check with their risk management on the use of volunteer crossing guards. (Administrators/Teachers/parents/volunteer and students)
- The City's traffic engineering would conduct a traffic count, and research a potential stop sign at Seventh and Stanford, and the best location of a crosswalk at the west end of Stanford.

The second meeting was on 4/23/15. At this meeting, staff provided background information regarding the current City contract with All City Management Services (ACMS) for crossing guards. The City conducted an evaluation including GGPD, the School District and ACMS in June of 2013 and agreed on the use of crossing guards at 18 locations within the City. These locations are all elementary schools with the exception one intermediate school and the crossing guards are primarily used on arterial streets. The City's cost is approximately \$197,000 for this contract per year.

Another factor discussed at this meeting that is impacting the use of Stanford is the school's modernization process. This is a three year construction project and the School is about 18 months into it. The modernization project has dislocated the student parking area to make room for modular classrooms. This has forced additional driving students on to Stanford and into neighboring parking lots.

As follow up items from the previous meeting, the School's Administration consulted with their Risk Management and found that administrators and teachers were not allowed to be used as crossing guards. They were also not comfortable with students being used. They did say they had volunteers and parents participating at other sites, however the Administration did not feel it was a viable option for GGHS.

From the City side, Traffic Engineering conducted the traffic study for the stop sign at Seventh and Stanford. That study did not meet warrants; therefore, Traffic Engineering is not recommending any modifications. They also looked at the current crosswalk location versus a new location for the west crosswalk. Traffic Engineering found the current crosswalk location was the most appropriate location. As a solution, Traffic Engineering is recommending the use of a median fence to prevent the random crossings of pedestrians and to encourage the use of the current crosswalks. The goal is to get the fence up as soon as possible and get feedback this school year on its effectiveness.

Another suggestion the City presented to the Administration was for the School District to enter into an agreement with the First Baptist Church of Garden Grove, located just west of the school on Euclid, for use as a drop off and pick up location for students. This could keep the additional traffic off Stanford and the students would be utilizing a controlled crosswalk to enter the north side of Stanford, then into the school. If this agreement can be secured, the School would then publicize the plan on its website to reach out to parents and students.

The School was in favor of installing the fence as soon as possible and they were going to reach out to the church to attempt to secure an agreement for use of the parking lot. The use agreement was identified as being a longer process and the school administration did not want to wait on the installation of the median fencing trail.

Presently, Traffic Engineering will be requesting the installation of a temporary fence in the median and reviewing its effectiveness through the end of this school year. Staff plans to meet just prior to the end of the school year to discuss the results with the all hands group.

Please feel free to contact me if you have any questions at extension 5994.

David R. Barlag
Public Safety Administrative Officer

Zimbra **davidba@ci.garden-grove.ca.us**

Median fencing

From : David Barlag <davidba@ci.garden-grove.ca.us>

Wed, Apr 29, 2015 09:31 AM

Subject : Median fencing**To :** Tony Aquino <tony1@ci.garden-grove.ca.us>

Tony,

I know that you had been working with Phil and PW on the fencing.

I just want to confirm that we are pushing that forward.

--

David R. Barlag
City Manager's Office
City of Garden Grove
(714) 741-5994

Zimbra

davidba@ci.garden-grove.ca.us

Manager's memo regarding GGHS

From : David Barlag <davidba@ci.garden-grove.ca.us>

Wed, Apr 29, 2015 02:36 PM

Subject : Manager's memo regarding GGHS 1 attachment**To :** Adam Zmija <adamz@ci.garden-grove.ca.us>, Tony Aquino
<tony1@ci.garden-grove.ca.us>

From: katrenas@ci.garden-grove.ca.us
To: "Dave Barlag" <davidba@ci.garden-grove.ca.us>
Sent: Wednesday, April 29, 2015 1:59:30 PM
Subject: Message from "ricoh106"

This E-mail was sent from "ricoh106" (Aficio MP 6001).

Scan Date: 04.29.2015 13:59:30 (-0700)
Queries to: katrenas@ci.garden-grove.ca.us

--

David R. Barlag
City Manager's Office
City of Garden Grove
(714) 741-5994

 **20150429135930350.pdf**
411 KB

City of Garden Grove

INTER-DEPARTMENT MEMORANDUM

To: Allan L. Roeder
Dept: Interim City Manager
Subject: GARDEN GROVE HIGH SCHOOL
STUDENT SAFETY UPDATE

From: David R. Barlag
Dept: CM Office
Date: April 28, 2015

There are concerns regarding student safety around Garden Grove High School (GGHS). The purpose of this memo is to provide an update of the current status.

To date, staff has met twice in an all hands meeting with the School District, School Administrators, and parents representing the Parent Teacher Student Association (PTSA).

The first meeting was on 3/24/15, City Staff listened to the concerns as they were expressed from members of the PTSA and Administration on site.

Primary issues raised by the school site were:

- Crosswalk locations,
- Use of crossing guards,
- Possibility of an additional stop sign at Seventh and Stanford.

Other points brought up by the City Staff included:

- Student/parent education through the school's website,
- Possible use of a traffic plan posted on the website,
- Median fence to prevent mid-street jay walking.

Both sides agreed to go back and research these issues further:

- The school was going to check with their risk management on the use of volunteer crossing guards. (Administrators/Teachers/parents/volunteer and students)
- The City's traffic engineering would conduct a traffic count, and research a potential stop sign at Seventh and Stanford, and the best location of a crosswalk at the west end of Stanford.

The second meeting was on 4/23/15. At this meeting, staff provided background information regarding the current City contract with All City Management Services (ACMS) for crossing guards. The City conducted an evaluation including GGPD, the School District and ACMS in June of 2013 and agreed on the use of crossing guards at 18 locations within the City. These locations are all elementary schools with the exception one intermediate school and the crossing guards are primarily used on arterial streets. The City's cost is approximately \$197,000 for this contract per year.

Another factor discussed at this meeting that is impacting the use of Stanford is the school's modernization process. This is a three year construction project and the School is about 18 months into it. The modernization project has dislocated the student parking area to make room for modular classrooms. This has forced additional driving students on to Stanford and into neighboring parking lots.

As follow up items from the previous meeting, the School's Administration consulted with their Risk Management and found that administrators and teachers were not allowed to be used as crossing guards. They were also not comfortable with students being used. They did say they had volunteers and parents participating at other sites, however the Administration did not feel it was a viable option for GGHS.

From the City side, Traffic Engineering conducted the traffic study for the stop sign at Seventh and Stanford. That study did not meet warrants; therefore, Traffic Engineering is not recommending any modifications. They also looked at the current crosswalk location verses a new location for the west crosswalk. Traffic Engineering found the current crosswalk location was the most appropriate location. As a solution, Traffic Engineering is recommending the use of a median fence to prevent the random crossings of pedestrians and to encourage the use of the current crosswalks. The goal is to get the fence up as soon as possible and get feedback this school year on its effectiveness.

Another suggestion the City presented to the Administration was for the School District to enter into an agreement with the First Baptist Church of Garden Grove, located just west of the school on Euclid, for use as a drop off and pick up location for students. This could keep the additional traffic off Stanford and the students would be utilizing a controlled crosswalk to enter the north side of Stanford, then into the school. If this agreement can be secured, the School would then publicize the plan on its website to reach out to parents and students.

The School was in favor of installing the fence as soon as possible and they were going to reach out to the church to attempt to secure an agreement for use of the parking lot. The use agreement was identified as being a longer process and the school administration did not want to wait on the installation of the median fencing trail.

Presently, Traffic Engineering will be requesting the installation of a temporary fence in the median and reviewing its effectiveness through the end of this school year. Staff plans to meet just prior to the end of the school year to discuss the results with the all hands group.

Please feel free to contact me if you have any questions at extension 5994.



David R. Barlag
Public Safety Administrative Officer

Zimbra

davidba@ci.garden-grove.ca.us

Amb RFP

From : David Barlag <davidba@ci.garden-grove.ca.us>

Wed, Apr 29, 2015 02:49 PM

Subject : Amb RFP

To : Omar Sandoval <osandoval@wss-law.com>

So now that the BOS has moved on the Amb RFP when will the first TRO be filed?

--

David R. Barlag
City Manager's Office
City of Garden Grove
(714) 741-5994

Zimbra

davidba@ci.garden-grove.ca.us

Re: Mandatory Training

From : David Barlag <davidba@ci.garden-grove.ca.us>

Mon, May 04, 2015 11:35 AM

Subject : Re: Mandatory Training**To :** Nicole Herrick <nicoleh@ci.garden-grove.ca.us>

So just for the record you are assigning this to new employees?

From: "Nicole Herrick" <nicoleh@ci.garden-grove.ca.us>**To:** "Han Kim" <hank@ci.garden-grove.ca.us>**Cc:** "David Barlag" <davidba@ci.garden-grove.ca.us>**Sent:** Monday, May 4, 2015 11:03:41 AM**Subject:** Re: Mandatory Training

Sure thing!

You should do 100 & 700 first. You probably won't be required to do 200 and 800 but you can just to have it under your belt. I did :)

Start with taking the interactive training course, then do the final exam. If you complete it successfully, you'll get a certificate. Keep one copy of your certificate for your records, send me one for your personnel file and one to David Barlag, he's maintaining the record for NIMS ICS trainings currently. I've copied him on this email in case you have additional questions.

Thanks for being proactive about this!

Required

<http://training.fema.gov/is/courseoverview.aspx?code=IS-100.b>

<http://training.fema.gov/is/courseoverview.aspx?code=IS-700.a>

Optional:

<http://training.fema.gov/is/courseoverview.aspx?code=IS-200.b>

<http://training.fema.gov/is/courseoverview.aspx?code=IS-800.b>

NICOLE HERRICK

City of Garden Grove|Human Resources

(714) 741-5533

nicoleh@ci.garden-grove.ca.us

From: "Han Kim" <hank@ci.garden-grove.ca.us>**To:** "Nicole Herrick" <nicoleh@ci.garden-grove.ca.us>

Sent: Friday, May 1, 2015 2:07:21 PM

Subject: Mandatory Training

Good Afternoon Nicole

My name is Han Kim and I am the new cadet for Crime Prevention. Last time when I went to the Customer Service Meeting, you have mentioned about a mandatory training from the fire department I think (the one that takes like 2 hours online) I was wondering if I could get the link to the website so that I can work on it when I have the time.

Thank You

--

David R. Barlag
City Manager's Office
City of Garden Grove
(714) 741-5994

City of Garden Grove

presents an introduction to:

Standardized Emergency Management System

SEMS - G606

National Incident Management System

NIMS

Objectives

- Understand the purpose and scope of SEMS/NIMIS.
- To recognize the five functions, the five components and the five levels of SEMS.
- Learn the basic definitions of some of the most common terms associated with SEMS/NIMIS.
- Know the basic elements of the SEMS/NIMIS law.

Acronyms

- **EOC (Emergency Operations Center)**
- **ICS (Incident Command System)**
- **MACCS (Multi-Agency Coordination System)**
- **OASIS (Operations Area Satellite Information System)**
- **OES (Office of Emergency Services)**
- **FEMMA (Federal Emergency Management Agency)**

Legal Basis for SEMMS



■ The 1991 “East Bay Hills Fire”
(Oakland)

■ Senate Bill 1841 “Petris” (1993)

■ Government Code 8607

■ California Code of Regulations Title 19

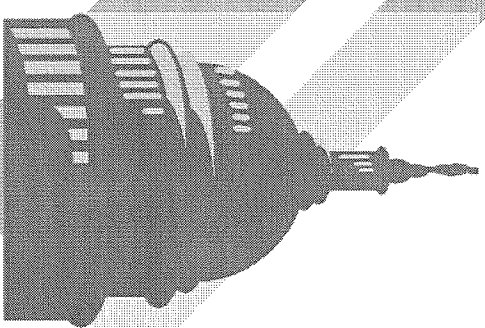



Legal Basis for NIMMS

- September 11th 2001
- Homeland Security created in 2002.
- Presidential Directive HSPD-5 (Feb. 28th, 2003)
- All agencies to be NIMMS compliant by the end of FY 2006

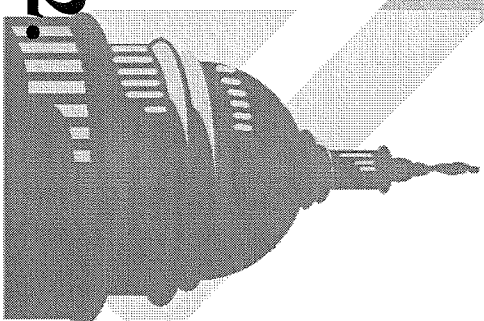

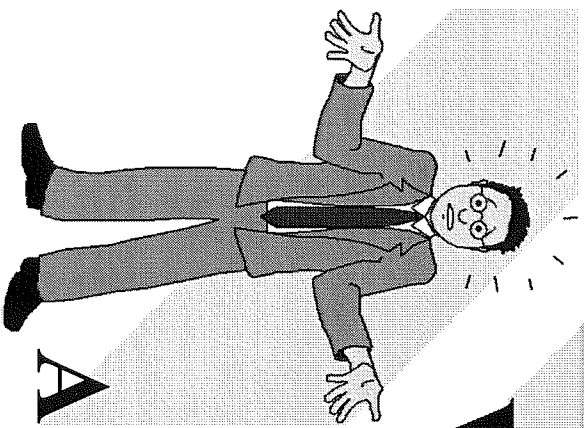

What is SEMS?

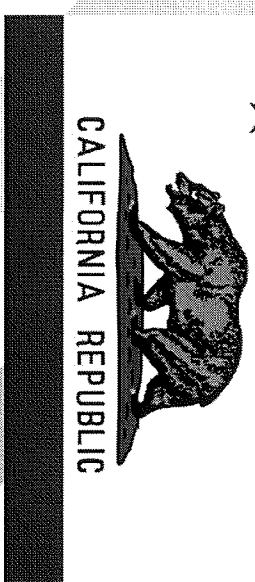

A management system to improve the Coordination, Cooperation, Communication of state and local emergency response in California.

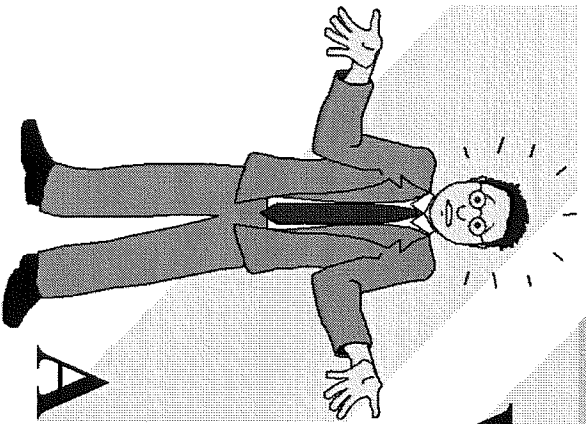

What is NIMS?

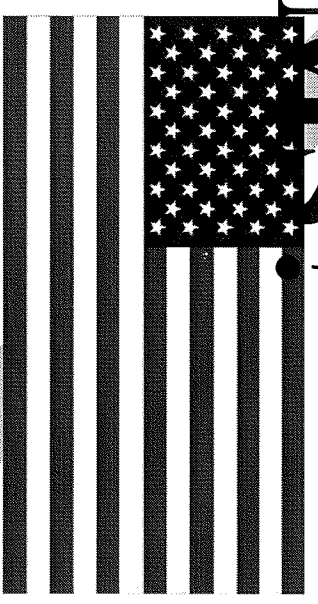

A management system to improve the Coordination, Cooperation, Communication of all government agencies during emergency responses in the United States.

Why Comply With

SEMS/NIMIS?

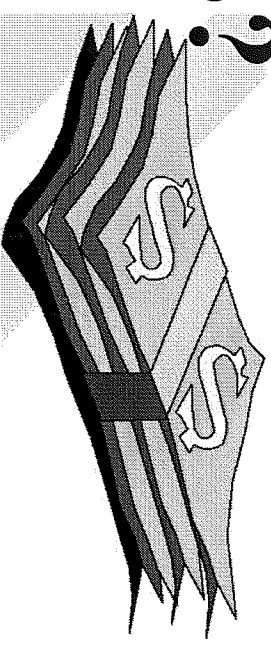

- Help the city to better survive disasters.
- A requirement for federal preparedness funding.

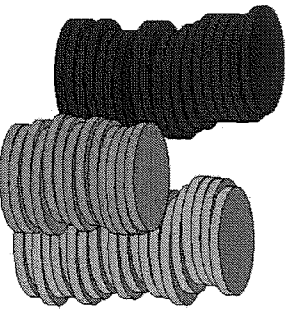

Common SEMS/NIMMS Features

- Incident Command System (ICS)
- Mutual Aid
- Multi-Agency Coordination

Differences Between SEMS and NIMS

- SEMS – A standardized emergency response system.
- NIMS – An emergency management program that incorporates SEMS.

When is SEMS/NIMIS Used?

- Fires
- Transportation Accidents
- Flood
- Earthquake
- Civil Unrest
- Storm
- Terrorism

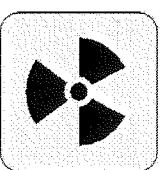
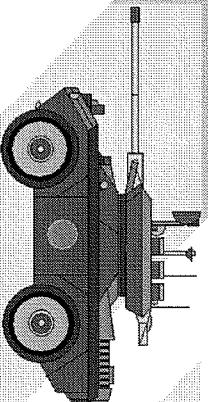
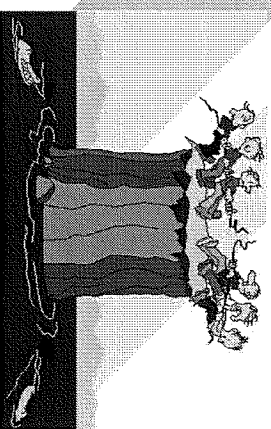
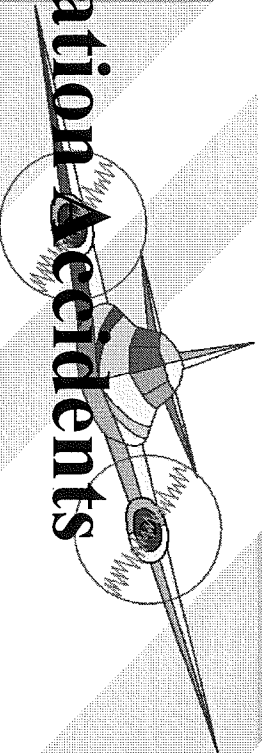

The Five Components of SEMS:

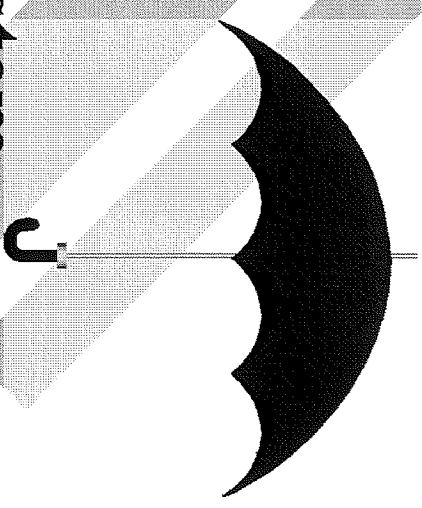

- Incident Command System.
- Multi-Agency Coordination System.
- Master Mutual Aid Agreement.
- Operational Areas.
- Operational Area Satellite Information System.



ICS

(Incident Command System)

- Developed in 1970 by FIRESCOPE.
- Provides standardization.
- Chain of command.
- Span of control.
- Expandable.
- Direct supervision.
- Common terminology.

MACCS

(Multi-Agency Coordination System)

Coordinates the effort of agencies involved in emergency activities through the EOC

(Emergency Operations Center).

- Facilitates decisions
- Prioritizes incidents
- Provides for the sharing of critical resources



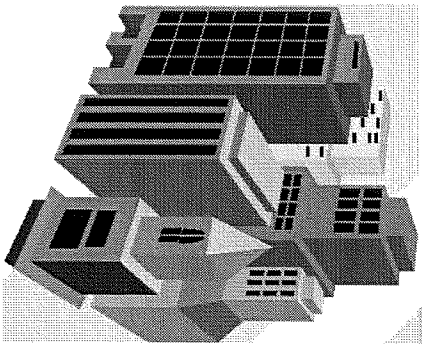

Master Mutual Aid Agreement

- Created in 1950.
- Cities, Counties and state voluntarily agree to provide services, resources and facilities to jurisdictions when local resources prove inadequate.

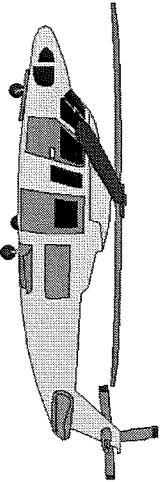

Operational Area Concept

- The Operational Area consists of all political subdivisions within the county boundaries.
- Orange County EOC is located at Loma Ridge.

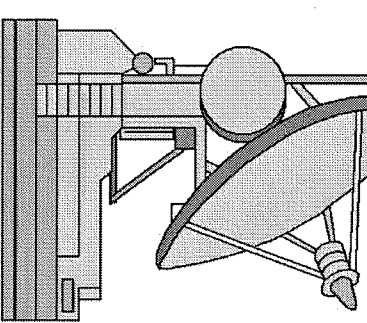

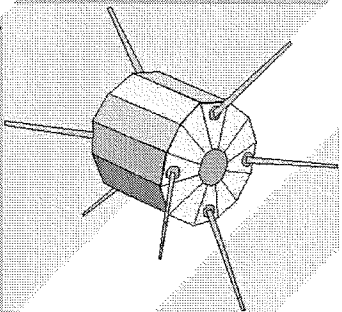

OASIS

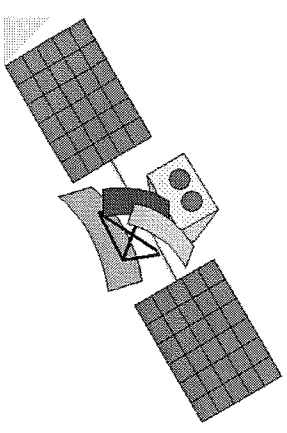

(Operational Area Satellite Information System)

- **A satellite based communications system with high frequency radio back-up.**
- **OASIS is a communications network that links three of the five SEMS organizational levels.**
- **Each Operational Area is equipped with a satellite system.**

The Five Organizational Levels of SEMIS:

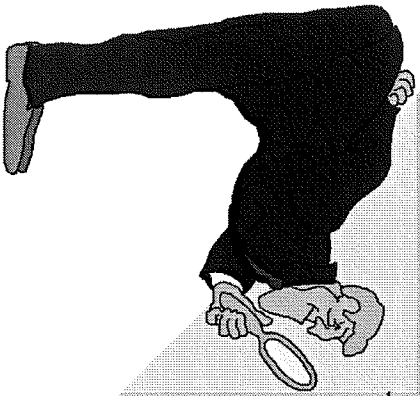

- 1. Field
- 2. Local government
- 3. Operational Area
- 4. Region
- 5. State

Field Level

- **Consists of emergency response personnel and resources.**
- **Direct response to incident or threat.**
- **Makes tactical decisions.**
- **Uses ICS.**

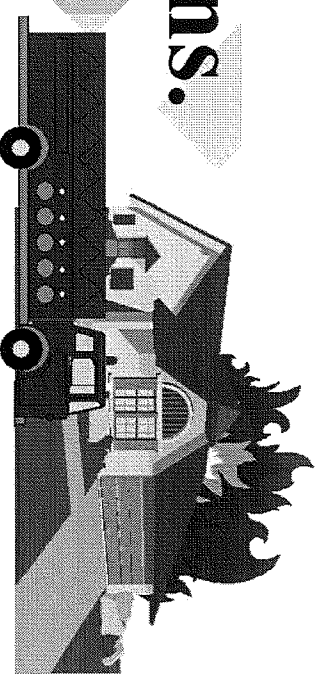

Local Government Level

- City of Garden Grove.
- Local governments manage the overall emergency response within their jurisdiction.
- EOC's
 - City Hall.
 - Public Works Yard.

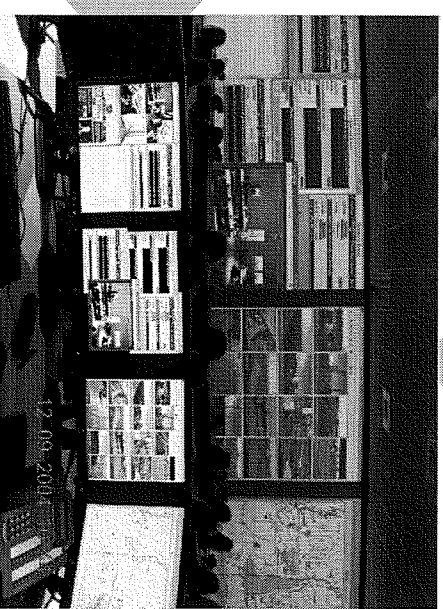

Operational Area

- Consists of all the political subdivisions in the county.
- Intermediate level.
- Manages and/or coordinates information resources and priorities of local governments.
- Links the Local and Regional levels.
- Each Operational Area represents a county.
- The Operational Area EOC is located at Loma Ridge.

Regional Level

- Link between the Operational Area and the State using OASIS.
- There are six Regions in the state.
- Garden Grove is in Region one.
- The Regional EOC located in Los Alamitos.

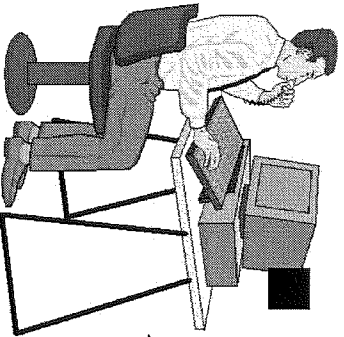

6 Regions

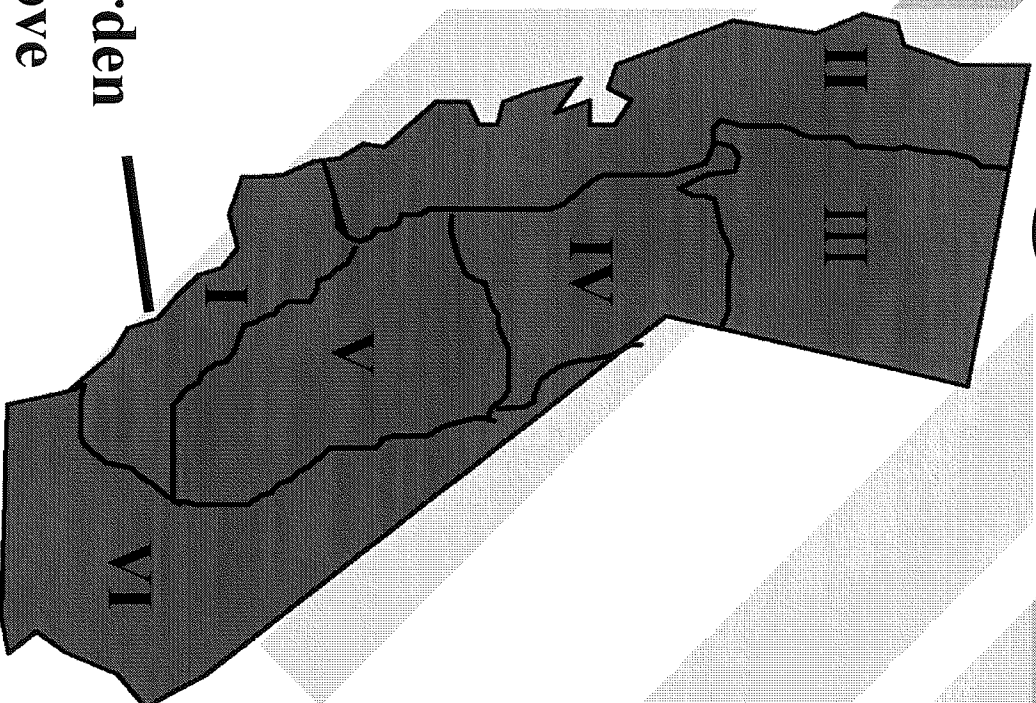

**Garden
Grove**

SEMS & NIMS Intro (c) GARDEN GROVE

State Level

- **Manages state resources in response to need of other levels.**
- **Coordinates mutual aid between Regions and between Regional level and the State.**
- **Link between the State and FEMA (Federal Emergency Management Agency).**
- **The State EOC located in Sacramento.**

The 5 Functions of SEMS/NIMS:

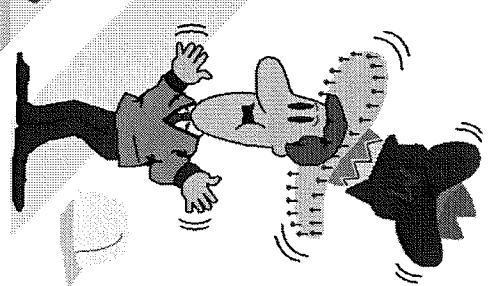
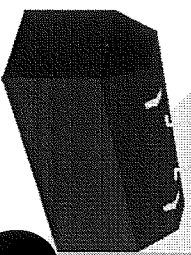

■ ICS:

- Command
- Operations
- Planning/Intelligence
- Logistics
- Finance/Administration



■ SEMS/NIMS:

- Management/Command
- Operations
- Planning/Intelligence
- Logistics
- Finance/Administration

ICS Functions

Command

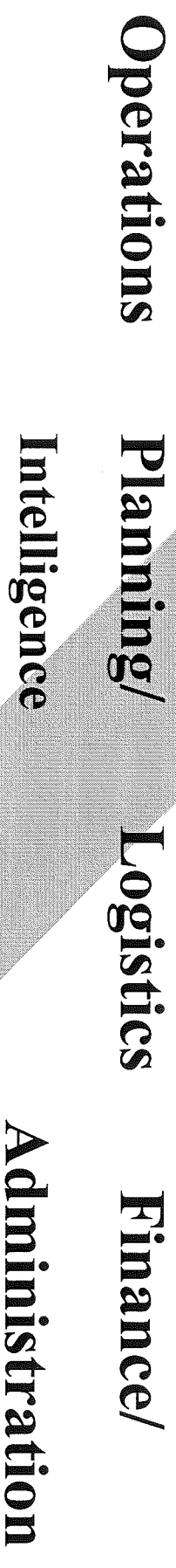

SEMS/NIMIS

Functions

Management/Command

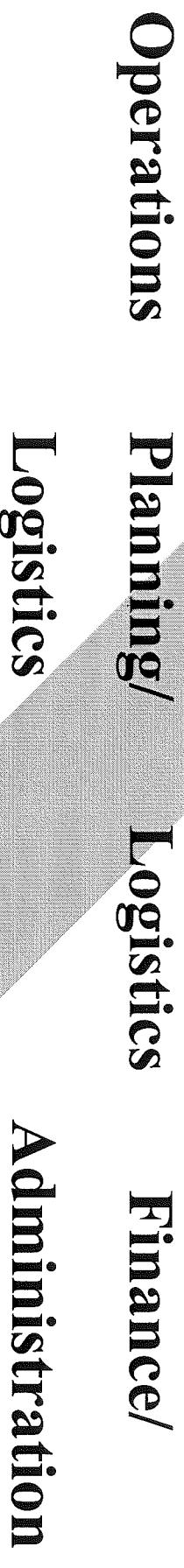

Summary

- **The use of SEMS and NIMS will improve the mobilization, deployment, utilization, tracking and demobilization of needed resources.**
- **The use of SEMS and NIMS will facilitate the flow of information and enhance coordination among all responding agencies.**

~~THE END~~

*The City
Of*

Garden Grove